

QUALITY CHANGES THE WORLD

PRODUCT
SPECIFICATIONS



STC550C5

SANY TRUCK CRANE
55T LIFTING CAPACITY

55T汽车起重机



55 t



45 m



2009 kN·m

LEFT & RIGHT HAND DRIVE AVAILABLE

左右舵可售

www.sanyglobal.com

V1.5

SANY TRUCK CRANE STC550C5 / 55T LIFTING CAPACITY



Optimal Configuration

主流配置 品质放心

DF Cummins ISLe340 30 engine, 9-speed FAST transmission with synchronizer.

Large displacement load sensitive piston pump.

High power hydraulic radiator.

东风康明斯 ISLe340 30 发动机, 法士特 9 档带同步器变速箱。

大排量负载敏感柱塞泵。

大功率液驱油散。



Optimal Performance

主流性能

45m boom, max. lifting moment of basic boom 2009kN.

m, max. lifting moment of full-extension boom of 1082kN.

m. Max capacity of full-extension boom of 9.5t. The lifting

performance leads in industry.

45m 主臂, 基本臂最大起重力矩 2009kN.m, 全伸臂最大起重力矩

1082kN.m, 全伸臂最大吊载 9.5t, 吊载能力行业领先。





Two Stage Outrigger 两级双低支腿

H-type layout, four point support, hydraulically telescoping at horizontal directions for stable operation.

H 型支腿 4 点支撑，一二级支腿全液压横向伸缩，吊载稳定。

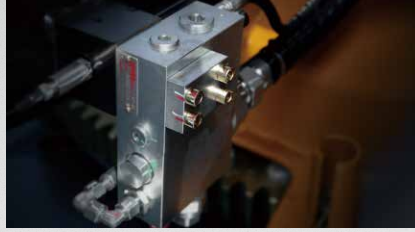

HBS Spool Balance Valve HBS 阀芯平衡阀

High precision, corrosion resistance and long service life.

精度高、耐腐蚀、寿命长。



More Stable System 系统更稳定

Large displacement load sensitive piston pump, large area hydraulic drive radiator, capable of continuous functioning under heavy workload.

大排量负载敏感柱塞泵，大风面液压驱动散热器，连续高负荷工作不过载。



Use-friendly Design 人性设计

Silica gel keypad integrated panel, making the operation clear at a glance.

350L large fuel tank with strong endurance.

硅胶按键集成面板，操作一目了然。

350L 大油箱，跑得远，干活久。



Overall Dimensions 整机尺寸图

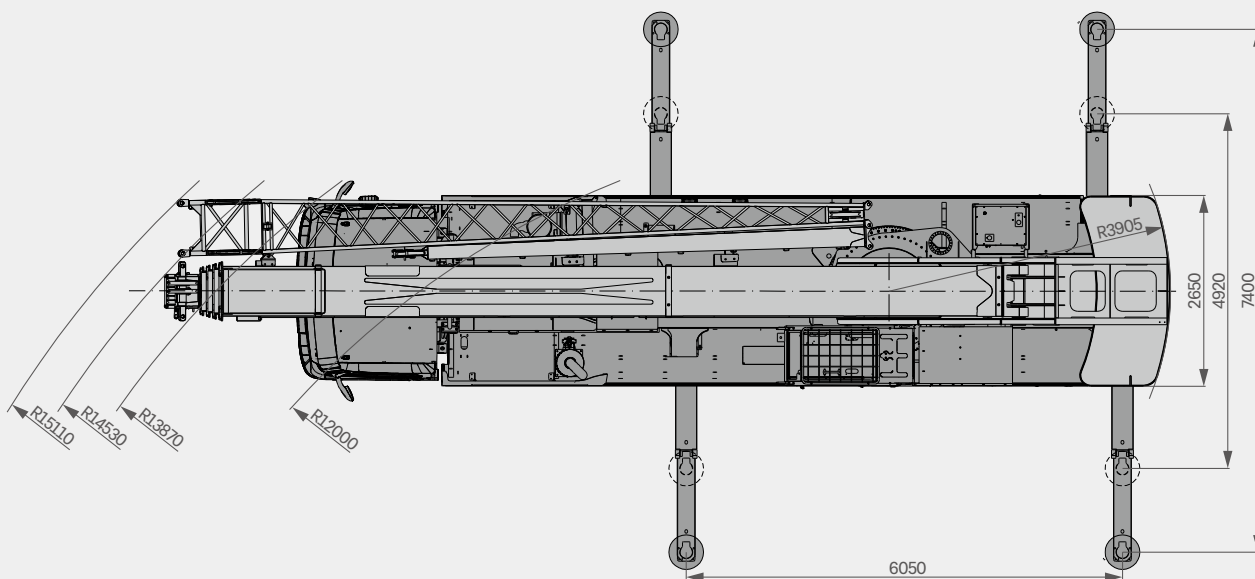
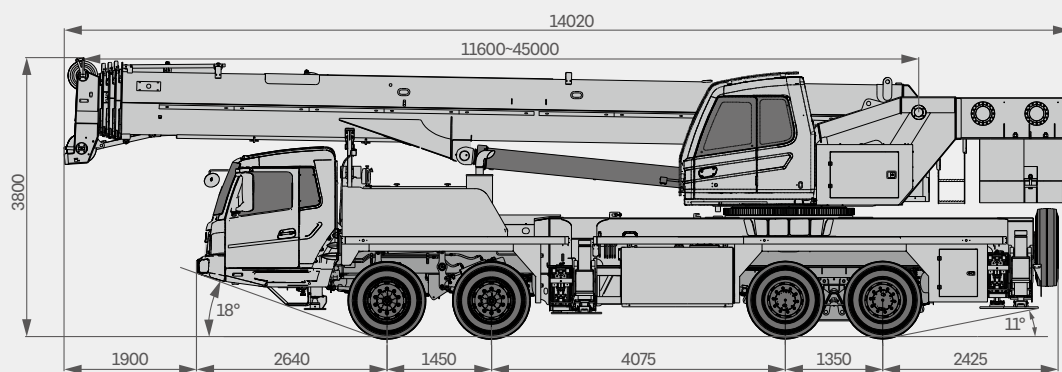

Technical Specification 主要性能参数

| CATEGORY 类型 | ITEM 项目 | UNIT 单位 | VALUE 参数 | |
|---|---------------------------------------|--|---|--------|
| CAPACITY 额定起重量 | Max. lifting capacity 最大起重量 | t | 55 | |
| WEIGHT 重量参数 | Gross weight 整机总质量 | kg | 41000 | |
| POWER 发动机参数 | Engine model 发动机型号 (排放标准) | - | DF Cummins ISLe340 30(Euro III) 东风康明斯 ISLe340 30(欧 III) | |
| | Max. engine power 发动机最大功率 | kW/rpm | 250/2100 | |
| | Max. engine torque 发动机最大输出扭矩 | N·m/rpm | 1425/1100~1400 | |
| DIMENSIONS 尺寸参数 | Overall length 整机全长 | mm | 14020 | |
| | Overall width 整机全宽 | mm | 2650 | |
| | Overall height 整机全高 | mm | 3800 | |
| TRAVEL 行驶参数 | Max. travel speed 最高行驶速度 | km/h | 90 | |
| | Steering radius 转弯半径 | Min.steering radius 最小转弯半径 | m | 12 |
| | | Min.steering radius of boom tip 臂头最小转弯半径 | m | 15.1 |
| | Wheel formula 车轮模式 | - | 8 × 4 | |
| | Min.ground clearance 最小离地间隙 | mm | 250 | |
| | Approach angle 接近角 | ° | 18 | |
| | Departure angle 离去角 | ° | 11 | |
| | Max.gradeability 最大爬坡度 | % | 47 | |
| | Fuel consumption per 100km 每 100 公里油耗 | L | 40 | |
| | MAIN PERFORMANCE 主要性能参数 | Working temperature range 使用温度区间 | °C | -20~45 |
| Min.rated lifting radius 最小额定幅度 | | m | 3 | |
| Tail slewing radius 转台尾部回转半径 | | mm | 3.93 | |
| Boom sections (Qty.) 臂节数 | | - | 5 | |
| Boom shape 臂形状 | | - | U shape U 形 | |
| Max.lifting moment 最大起重力矩 | | Basic boom 基本臂 | kN·m | 2009 |
| | | Full-extension boom 全伸主臂 | kN·m | 1082 |
| | | Full-extension boom + jib 全伸主臂 + 副臂 | kN·m | 390 |
| Boom length 臂长 | | Basic boom 基本臂 | m | 11.6 |
| | | Full-extension boom 全伸主臂 | m | 45 |
| | | Full-extension boom + jib 全伸主臂 + 副臂 | m | 61 |
| Max.lifting height 最大起重高度 | | Basic boom 基本臂 | m | 12.1 |
| | | Full-extension boom 全伸主臂 | m | 45.5 |
| | Full-extension boom + jib 全伸主臂 + 副臂 | m | 61.5 | |
| Outrigger span (Longitudinal × Transverse) 支腿跨距 (纵 × 横) | m | 6.05 × 7.4 | | |
| Jib offset 副臂安装角度 | ° | 0, 15, 30 | | |
| AIRCONDITIONER 空调 | In operator's cab 上车空调 | - | Cooling 制冷 | |
| | In driver's cab 下车空调 | - | Heating & cooling 制冷、制热 | |

Technical Parameters 主要参数表



Axle Load 轴荷

| Axle 轴 | 1 | 2 | 3 | 4 | Gross weight 总重量 |
|-----------------|-----|-----|----|----|------------------|
| Axle load 轴荷 /t | 7.5 | 7.5 | 13 | 13 | 41 |
| Remark 备注 | - | | | | |



Hook 吊钩

| Rated load 额载 /t | Number of sheaves 滑轮数量 | Rope rate 倍率 | Hook weight 吊钩重量 /kg |
|------------------|------------------------|--------------|----------------------|
| 60 | 6 | 12 | 550 |
| 6 | / | 1 | 120 |



Operations 主要动作参数

| Item 项目 | Max.single rope lifting speed (empty load) 单绳速度 (空载) | Rope diameter/length 钢丝绳直径 / 长度 | Max. single line pull 最大单绳拉力 |
|--|--|------------------------------------|---------------------------------|
| Main winch 主卷扬 | 125m/min | 18mm/215m | 5t |
| Auxiliary winch 副卷扬 | 125m/min | 18mm/135m | 5t |
| Slewing speed 回转速度 | 0-2r/min | | |
| Full luffing up/down time of boom 主臂起落幅时间 | 60s/90s | | |
| Full extension/retraction time of boom 主臂伸缩时间 | 100s/120s | | |
| Outrigger jack 垂直支腿 | Retraction 收 | 30s | |
| | Extension 放 | 30s | |
| Outrigger beam 水平支腿 | Retraction 收 | 20s | |
| | Extension 放 | 35s | |

Crane Introduction 整机介绍

Carrier 下车

Driver's cab 驾驶室

- Self-developed full width cab in ergonomic design, featuring vibration reduction and external noise isolation. Equipped with HVAC, stereo radio, and full set of instrument and controls, realizing safety and comfort.
- 自主开发全宽钢整体式钢结构驾驶室，采用人体工程学原理设计，减震性和封闭性优良。冷暖空调、立体收音机等，控制仪器和仪表齐全。

Carrier frame 车架

- Designed and manufactured by Sany, the anti-torsion box-type structure welded with high-strength steel, featuring increased bearing capacity.
- 三一设计、制造，由细晶粒高强度钢板焊接而成的防扭转箱形结构，承载能力强。

Engine 发动机

- Model: DF Cummins Inline six-cylinder diesel engine with watercooler and inter cooler.
- Emission standard: Euro III .
- Fuel reservoir capacity: 350L.
- 型式：直列六缸、水冷却、增压中冷、柴油发动机。
- 排放标准：欧三。
- 燃料箱有效容积：350L。

Transmission 变速箱

- 9-speed manual transmission with synchronizer, large speed ratio range, adaptable to slope climbing and high-speed traveling.
- 9 档手动变速箱带同步器，速比范围大，既可满足低速场地爬坡 行驶，又可满足高速行驶。

Transmission shaft 传动轴

- Optimized layout, higher torque output via contrate gear connecting transmission shaft cardan.
- 优化的传动轴布置，传动轴传动平稳、可靠。最优化力传输，采用端面齿联结传动轴，传递扭矩大。

Axle 车桥

- Axles 1, 2 are steered; axles 3, 4 are drive axles with built-in differential lock, realizing tougher ability to rough-terrain travelling. Two-stage reducer gear and smaller gear package contribute to better accessibility. Press-welding axle housing technology, bearing capacity is stronger.
- 3、4 轴为驱动轴，1、2 轴为转向轴，驱动轴内置轴间和轮间差速器锁，使车辆有更强的脱困能力；双级减速，桥包体积更小，使车辆有更好的通过性；冲焊桥壳工艺，承载能力更强。

Suspension system 悬挂

- Axle 1 & 2 adopt leaf spring suspension, axle 3 & 4 adopt rubber suspension. The system's strength is verified by 100,000 cycling fatigue tests to ensure both strength and ride comfort.
- 一二桥采用钢板弹簧悬挂系统，三四桥采用橡胶悬挂系统，悬挂系统经过超过 10 万次的疲劳试验，保证强度的同时兼顾乘坐的舒适性。

Steering 转向系统

- Equipped with servo power brake, double circuit system hydraulic steering.
- Mechanical steering mechanism, linkage feedback with hydro booster.
- 配置伺服动力转向器，双回路系统液压转向装置。
- 机械式转向机构，采用杆系反馈的液压助力转向系统。

Tires 轮胎

- 12 radial vacuum tires sized 315/80R22.5, strong bearing capacity and durability.
- 12 (轮胎数) 一轮胎规格: 315/80R22.5, 钢丝真空轮胎, 承载能力大, 耐用。

Wheel formula 车轮模式

- 8 × 4 × 4。

Outrigger 支腿

- H-type layout, four point support with high strength steel plate, span (longitudinal × transverse) of 6.05m × 7.4m, easy to operate. Outriggers hydraulically telescoping at horizontal directions.
- H 型支腿 4 点支撑，纵、横跨距 6.05m × 7.4m，易操作、稳定性强；采用细晶粒高强度钢板材料，一、二级支腿全液压横向伸缩。支腿垂直油缸采用双向液压锁进行安全保护。

Brake 制动系统

- The braking system includes service brake & parking brake & emergency brake & assisting brake.
- Service brake: air servo, dual circuit; front axle adopts key-operated brake + dual air chamber, delivering stronger braking performance.
- Parking brake: functioning at axles 3 and 4 by spring-loaded air chamber.
- Emergency brake: performed by accumulator releasing pressure.
- Assisting brake: engine exhaust brake, safety assured when driving down long slopes.
- 制动系统包括行车制动、驻车制动、应急制动和辅助制动。
- 行车制动采用双回路制动系统，所有车轮均用空气伺服制动器，前桥采用楔式制动器 + 双气室，制动能力更强。
- 驻车制动是通过气室内弹簧作用在第三、四桥上。
- 应急制动阀由蓄能器储能断气制动兼做应急制动。
- 辅助制动为排气制动，保证在下长坡时的制动安全，保证行车的安全可靠。

Electrical system 电气系统

- 24V DC power supply can be used to cut off the chassis power; Equipped with automotive lighting system; The movements of cranes, such as throttle and outrigger control, are controlled by electric control, making the movements convenient and fast. The electrical system has a strong ability of detection, logic and operation, and has the functions of self diagnosis, centralized display and self protection.
- 采用 24V 直流电源，可实现下车电源切断；配备汽车照明系统；车辆的动作，如油门、支腿操纵等都经电气控制实现，使动作轻便、快捷；电气系统有很强的检测、逻辑、运算等能力，具故障自诊断、集中显示及自我保护功能。

Crane Introduction 整机介绍

Operator's cab 操纵室

- Large interior space with safety glass, corrosion-resistant steel plate, equipped with fully covered softened interior, panoramic skylight, adjustable seats and other convenient design; Equipped with AC, electric wiper, making the operation more comfortable and easy; 7 inch display screen is configured to realize the combination of the main control console and operation display system, so that all working conditions of lifting operation data is clear at a sight.
- 超大内部空间, 采用安全玻璃, 耐腐蚀钢板, 配置全覆盖软化内饰、全景式天窗、可调式座椅等人性化设计, 配有空调、电动雨刮器, 操作更舒适、轻松; 配置 7 英寸显示屏, 实现主控台与操作显示系统有机结合, 使吊装作业的全部工况数据一目了然。

Boom & telescoping system 伸缩系统

- The boom structure adopts anti-distortion design, high strength steel plate and five U-shaped sections with high stability; Full-extension length of boom is 45m, jib length of 16m, lifting height of full-extension boom is 45.5m, max. lifting height of boom+jib is 61.5m; Boom telescopes via double cylinder with rope arranger, to achieve multiple boom length combinations.
- 臂结构采用抗扭曲设计, 具有极高的稳定性; 5 节 U 型主臂, 采用高强度钢板制作, 全伸臂长 45m, 副臂 16m, 主臂全伸起升高度 45.5m, 带副臂最大起升高度 61.5m; 伸缩采用双缸 + 绳排机构, 多种臂长组合。

Hoist 起升系统

- Efficient and energy saving speed regulation is realized by via double variables of pump and motor. Normally closed type winch brake, winch balance valve coupled with exclusive anti-slip tech contribute to smoother hoisting.
- Normally closed type winch brake, winch balance valve available to avoid hook stall.
- Standard 6t, 55t hook and rotation resistant wire rope with diameter 18mm, length 215mm.
- 泵、马达双变量调速, 高效节能。卷扬平衡阀与独特的防溜钩技术完美结合, 重物起落平稳。
- 常闭式卷扬制动器, 并设置卷扬平衡阀, 可防止落钩失速。
- 标配 6t、55t 吊钩, 直径 $\phi 18\text{mm}$, 长 215m 阻旋转钢丝绳 (主)。

Luffing system 变幅系统

- Passive luffing down, reducing energy cost. Adopts single cylinder and front hinge arrangement, provides more energy saving luffing and lifting boom force is improved; Electric proportional control balance valve. Luffing angle: $-2^{\circ}\sim 80^{\circ}$.
- 自重落幅, 更加节能。采用单根油缸, 前铰支布置, 变幅更省力且起重臂受力得到改善采用电比例控制平衡阀。变幅角度: $-2^{\circ}\sim 80^{\circ}$ 。

Counterweight 配重

- Fixed counterweight 5.2t, movable counterweight 2.3t. Capable of traveling with the full counterweight.
- 固定配重 5.2t, 活动配重 2.3t。可带全配重转场。

Hydraulics 液压系统

- High quality main oil pump, main valve, winch motor, slewing motor, balance valve and other key hydraulic components, to ensure the stability and reliability of the hydraulic system; The main valve has flow compensation and load feedback control functions, which can easily realize the stable control of single action and combined action under various working conditions.
- High quality winch motor, making operation reliable; Max. single rope speed of main winch and auxiliary winch 125/min.
- Adopts new hydraulic control variable slewing system, smooth slewing start & control with excellent inching performance.
- 采用稳定、高品质的主油泵、主阀、卷扬马达、回转马达、平衡阀等关键液压件, 系统可靠性高; 通过精确的参数匹配, 操控性能优越, 主阀具备流量补偿、负载反馈控制功能, 能在各种工况下, 轻松实现单个动作和组合动作的稳定控制。
- 卷扬采用高品质马达, 作业可靠; 主副卷扬单绳最大速度达 125m/min。
- 采用新型液控变量回转系统, 回转启动和控制更为平稳, 微动性更卓越。

Slewing 回转系统

- 360° slewing and max. slewing speed 2r/min, hydraulic proportional speed regulation, the action is stable and the system is reliable. Unique slewing buffer design, make the braking more stable.
- 360° 回转最大回转速度 2r/min, 采用液控比例调速控制, 动作稳定, 系统可靠; 独特的回转缓冲设计, 制动更平稳。

Control system 控制系统

- Load moment indicator: A method of analytical mechanics is adopted and a moment limiter calculation system based on the hoisting mechanics model is established. Through online empty-load calibration, the rated hoisting accuracy can reach $\pm 3\%$ to fully protect the hoisting operation. In case of overload, the system will automatically give an alarm to provide safety guarantee for operation.
- The hydraulic system is equipped with hydraulic balance valve, overflow valve, two-way hydraulic lock, etc. to realize the stability and reliability of the hydraulic system.
- The main and auxiliary hoists are equipped with three-circle protectors to prevent over-hoist-down of the wire rope.
- Boom head and jib are equipped with A2B switch to prevent the wire rope from over winding.
- The length & angle sensor and pressure sensor are equipped with to display the operating status of the crane in real time, automatically cut off dangerous actions, and give a buzzer alarm.
- 力矩限制器: 采用分析力学方法, 建立了基于吊重力学模型的力矩限制器计算系统, 通过在线空载标定, 额定吊重精度达到 $\pm 3\%$, 全方位保护吊装作业; 超载作业时, 系统自动报警提示, 为操纵作业提供安全保障。
- 液压系统配置液压平衡阀、溢流阀、双向液压锁等元件, 实现液压系统稳定可靠;
- 主、副卷扬配置三圈保护器, 防止钢丝绳过放。
- 主、副臂臂端配置高度限位器, 防止钢丝绳过卷。
- 配置长度角度传感器、压力传感器, 实时显示起重机作业状态, 自动切断危险动作, 蜂鸣报警。

Optional equipment at extra fees 选配

- Anemometer, reversing camera, spark arrester, intake shutoff valve.
- 风速仪, 倒车影像, 火星灭火器, 进气切断阀。

Operating Range 起升高度

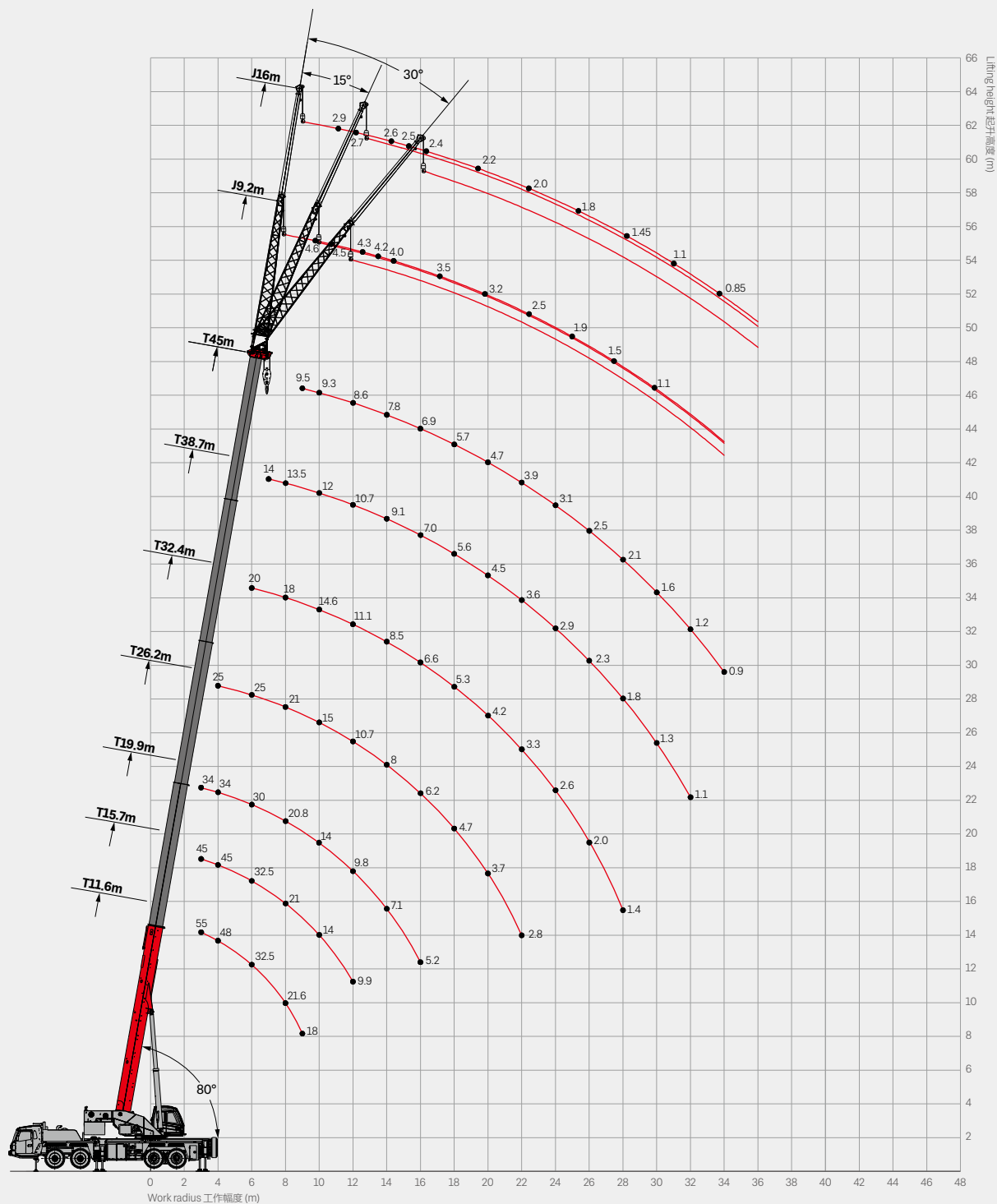

Load Chart-Telescopic Boom 主臂性能表



Unit: kg

| Radius (m) 幅度 | 11.6 | 15.8 | 20.0 | 26.2 | 32.5 | 38.7 | 45.0 | 17.9 | 24.1 | 30.4 | 36.7 | 22.0 | 28.3 | 34.6 | 40.8 | Radius (m) 幅度 |
|------------------------------------|-------|-------|-------|-------|-------|-------|------|-------|-------|-------|-------|-------|-------|-------|------|----------------------|
| 3 | 55000 | 45000 | 34000 | | | | | 25000 | | | | | | | | 3 |
| 3.5 | 51000 | 45000 | 34000 | | | | | 25000 | | | | | | | | 3.5 |
| 4 | 48000 | 45000 | 34000 | 25000 | | | | 25000 | 22500 | | | 25000 | | | | 4 |
| 4.5 | 45000 | 43000 | 34000 | 25000 | | | | 25000 | 22500 | | | 25000 | | | | 4.5 |
| 5 | 41000 | 40000 | 33000 | 25000 | | | | 25000 | 22500 | | | 25000 | 21500 | | | 5 |
| 5.5 | 36000 | 36000 | 32000 | 25000 | 20000 | | | 25000 | 22000 | 15000 | | 25000 | 21500 | | | 5.5 |
| 6 | 32500 | 32500 | 30000 | 25000 | 20000 | | | 25000 | 22000 | 14500 | | 25000 | 21500 | | | 6 |
| 7 | 26800 | 26500 | 25500 | 23000 | 19500 | 14000 | | 25000 | 20000 | 13500 | 10500 | 25000 | 21000 | 14500 | | 7 |
| 8 | 21600 | 21000 | 20800 | 21000 | 18000 | 13500 | | 23000 | 18000 | 12500 | 10500 | 23000 | 21000 | 14000 | 9800 | 8 |
| 9 | 18000 | 17200 | 17000 | 17700 | 16500 | 13000 | 9500 | 19000 | 16500 | 11500 | 10000 | 18500 | 19000 | 13000 | 9200 | 9 |
| 10 | | 14000 | 14000 | 15000 | 14600 | 12000 | 9300 | 15700 | 15500 | 11000 | 9500 | 15200 | 15700 | 12200 | 8700 | 10 |
| 11 | | 11800 | 11500 | 12500 | 12700 | 11500 | 9100 | 13200 | 13600 | 10500 | 9000 | 13000 | 13500 | 11400 | 8300 | 11 |
| 12 | | 9900 | 9800 | 10700 | 11100 | 10700 | 8600 | 11200 | 11700 | 9800 | 8400 | 11000 | 11500 | 10600 | 7900 | 12 |
| 14 | | | 7100 | 8000 | 8500 | 9100 | 7800 | 8600 | 9100 | 8300 | 7500 | 8300 | 8700 | 8900 | 7200 | 14 |
| 16 | | | 5200 | 6200 | 6600 | 7000 | 6900 | | 7200 | 7200 | 6400 | 6400 | 6900 | 7200 | 6600 | 16 |
| 18 | | | | 4700 | 5300 | 5600 | 5700 | | 5800 | 6000 | 5600 | 5000 | 5500 | 5800 | 5800 | 18 |
| 20 | | | | 3700 | 4200 | 4500 | 4700 | | | 5100 | 4800 | | 4400 | 4800 | 5000 | 20 |
| 22 | | | | 2800 | 3300 | 3600 | 3900 | | | 4200 | 4200 | | 3600 | 3900 | 4100 | 22 |
| 24 | | | | | 2600 | 2900 | 3100 | | | 3600 | 3700 | | | 3200 | 3400 | 24 |
| 26 | | | | | 2000 | 2300 | 2500 | | | | 3100 | | | 2600 | 2800 | 26 |
| 28 | | | | | 1400 | 1800 | 2100 | | | | 2600 | | | 2100 | 2400 | 28 |
| 30 | | | | | | 1300 | 1600 | | | | 2200 | | | | 1900 | 30 |
| 32 | | | | | | 1000 | 1200 | | | | | | | | 1400 | 32 |
| 34 | | | | | | | 900 | | | | | | | | 1100 | 34 |
| 36 | | | | | | | | | | | | | | | | 36 |
| 38 | | | | | | | | | | | | | | | | 38 |
| Telescoping status (%) 伸缩模式 | | | | | | | | | | | | | | | | |
| Cylinder I 油缸 I | 0 | 50 | 100 | 100 | 100 | 100 | 100 | 0 | 0 | 0 | 0 | 50 | 50 | 50 | 50 | Cylinder I 油缸 I |
| Cylinder II 油缸 II | 0 | 0 | 0 | 25 | 50 | 75 | 100 | 25 | 50 | 75 | 100 | 25 | 50 | 75 | 100 | Cylinder II 油缸 II |
| Rope rate 钢丝绳倍率 | 12 | 10 | 8 | 6 | 5 | 4 | 3 | 6 | 5 | 4 | 3 | 6 | 5 | 4 | 3 | Rope rate 钢丝绳倍率 |

Load Chart-Telescopic Boom 主臂性能表



Unit: kg

| Radius (m) 幅度 | 11.6 | 15.8 | 20.0 | 26.2 | 32.5 | 38.7 | 45.0 | 17.9 | 24.1 | 30.4 | 36.7 | 22.0 | 28.3 | 34.6 | 40.8 | Radius (m) 幅度 |
|------------------------------------|-------|-------|-------|-------|-------|-------|------|-------|-------|-------|-------|-------|-------|-------|------|----------------------|
| 3 | 55000 | 45000 | | | | | | 25000 | | | | | | | | 3 |
| 3.5 | 51000 | 45000 | 34000 | | | | | 25000 | | | | | | | | 3.5 |
| 4 | 48000 | 45000 | 34000 | | | | | 25000 | | | | 25000 | | | | 4 |
| 4.5 | 45000 | 42000 | 34000 | 25000 | | | | 25000 | 22500 | | | 25000 | | | | 4.5 |
| 5 | 41000 | 38000 | 33000 | 25000 | | | | 25000 | 22500 | | | 25000 | 21500 | | | 5 |
| 5.5 | 36000 | 34000 | 32000 | 25000 | 20000 | | | 25000 | 22000 | 15000 | | 25000 | 21500 | | | 5.5 |
| 6 | 32000 | 31000 | 30000 | 25000 | 20000 | | | 25000 | 22000 | 14500 | | 25000 | 21500 | | | 6 |
| 7 | 26500 | 26000 | 25500 | 23000 | 19500 | 14000 | | 25000 | 20000 | 13500 | 10500 | 25000 | 21000 | 14500 | | 7 |
| 8 | 20200 | 20000 | 19700 | 20500 | 18000 | 13500 | | 21500 | 18000 | 12500 | 10500 | 21300 | 19000 | 14000 | 9800 | 8 |
| 9 | 16000 | 15800 | 15500 | 16500 | 16500 | 13000 | 9500 | 17500 | 16500 | 11500 | 10000 | 17000 | 17600 | 13000 | 9200 | 9 |
| 10 | | 12800 | 12500 | 13500 | 14200 | 12000 | 9300 | 14500 | 15000 | 11000 | 9500 | 14000 | 14500 | 12200 | 8700 | 10 |
| 11 | | 10600 | 10300 | 11300 | 12000 | 11500 | 9100 | 12200 | 12700 | 10500 | 9000 | 11800 | 12300 | 11400 | 8300 | 11 |
| 12 | | 8900 | 8700 | 9700 | 10200 | 10500 | 8600 | 10500 | 10900 | 9800 | 8400 | 10000 | 10500 | 10600 | 7900 | 12 |
| 14 | | | 6200 | 7200 | 7700 | 8000 | 7800 | 7900 | 8300 | 8300 | 7300 | 7400 | 8000 | 8400 | 7200 | 14 |
| 16 | | | 4500 | 5400 | 5900 | 6200 | 6500 | | 6500 | 6900 | 6400 | 5700 | 6200 | 6600 | 6600 | 16 |
| 18 | | | | 4100 | 4600 | 4900 | 5200 | | 5200 | 5500 | 5600 | 4400 | 4900 | 5200 | 5500 | 18 |
| 20 | | | | 3100 | 3600 | 3900 | 4200 | | | 4500 | 4700 | | 3900 | 4200 | 4500 | 20 |
| 22 | | | | 2300 | 2800 | 3100 | 3400 | | | 3700 | 3900 | | 3100 | 3400 | 3700 | 22 |
| 24 | | | | | 2200 | 2400 | 2700 | | | 3100 | 3300 | | | 2700 | 3000 | 24 |
| 26 | | | | | 1600 | 1900 | 2200 | | | | 2700 | | | 2200 | 2400 | 26 |
| 28 | | | | | | 1500 | 1700 | | | | 2300 | | | 1800 | 2000 | 28 |
| 30 | | | | | | | 1300 | | | | 1900 | | | | 1600 | 30 |
| 32 | | | | | | | 1000 | | | | | | | | 1300 | 32 |
| 34 | | | | | | | | | | | | | | | | 34 |
| 36 | | | | | | | | | | | | | | | | 36 |
| 38 | | | | | | | | | | | | | | | | 38 |
| Telescoping status (%) 伸缩模式 | | | | | | | | | | | | | | | | |
| Cylinder I 油缸 I | 0 | 50 | 100 | 100 | 100 | 100 | 100 | 0 | 0 | 0 | 0 | 50 | 50 | 50 | 50 | Cylinder I 油缸 I |
| Cylinder II 油缸 II | 0 | 0 | 0 | 25 | 50 | 75 | 100 | 25 | 50 | 75 | 100 | 25 | 50 | 75 | 100 | Cylinder II 油缸 II |
| Rope rate 钢丝绳倍率 | 12 | 10 | 8 | 6 | 5 | 4 | 3 | 6 | 5 | 4 | 3 | 6 | 5 | 4 | 3 | Rope rate 钢丝绳倍率 |

Load Chart-Jib 副臂性能表



Unit: kg

| Boom angle (°) 主臂仰角 | 45m+9.2m | | | 45m+16m | | | Boom angle (°) 主臂仰角 |
|-------------------------|----------|------|------|---------|------|------|-------------------------|
| | 0° | 15° | 30° | 0° | 15° | 30° | |
| 78 | 4600 | 3300 | 2500 | 2900 | 1900 | 1400 | 78 |
| 77 | 4500 | 3200 | 2500 | 2700 | 1800 | 1350 | 77 |
| 75 | 4300 | 3100 | 2500 | 2600 | 1700 | 1300 | 75 |
| 74 | 4200 | 3000 | 2400 | 2500 | 1700 | 1250 | 74 |
| 73 | 4000 | 2800 | 2300 | 2400 | 1600 | 1200 | 73 |
| 70 | 3500 | 2700 | 2200 | 2200 | 1500 | 1150 | 70 |
| 67 | 3200 | 2500 | 2000 | 2000 | 1400 | 1150 | 67 |
| 64 | 2500 | 2200 | 1900 | 1800 | 1300 | 1100 | 64 |
| 61 | 1900 | 1700 | 1600 | 1450 | 1050 | 1000 | 61 |
| 58 | 1500 | 1350 | 1250 | 1100 | 900 | 850 | 58 |
| 55 | 1100 | 1000 | 950 | 850 | 700 | 700 | 55 |



Unit: kg

| Boom angle (°) 主臂仰角 | 45m+9.2m | | | 45m+16m | | | Boom angle (°) 主臂仰角 |
|-------------------------|----------|------|------|---------|------|------|-------------------------|
| | 0° | 15° | 30° | 0° | 15° | 30° | |
| 78 | 4600 | 3300 | 2500 | 2900 | 1900 | 1400 | 78 |
| 77 | 4500 | 3200 | 2500 | 2700 | 1800 | 1350 | 77 |
| 75 | 4300 | 3100 | 2500 | 2600 | 1700 | 1300 | 75 |
| 74 | 4200 | 3000 | 2400 | 2500 | 1700 | 1250 | 74 |
| 73 | 4000 | 2800 | 2300 | 2400 | 1600 | 1200 | 73 |
| 70 | 3500 | 2700 | 2200 | 2200 | 1500 | 1150 | 70 |
| 67 | 2800 | 2500 | 2000 | 2000 | 1400 | 1150 | 67 |
| 64 | 2200 | 1900 | 1800 | 1600 | 1300 | 1100 | 64 |
| 61 | 1600 | 1500 | 1300 | 1200 | 900 | 800 | 61 |
| 58 | 1200 | 1000 | 950 | 900 | 700 | 600 | 58 |

Remark:

1. Value listed are the max. capacity when the crane is in a level condition on solid ground or surface.
2. Radius refers to actual radius with boom deflection considered.
3. Value above are calculated with hooks and lifting slings considered (551kg main hook block, 100kg aux. hook block).
4. When the fifth outrigger is landed in position, value listed are applicable for 360 degree operation.
5. Rated lifting performance on boom point sheave equals 5000kg; boom load capacity shall be 2300kg less than value given when jib unfolds.
6. Load value is given according to the larger radius or boom length value when the actual radius or boom length falls between two numbers above.

备注:

1. 起重性能表中给定数值是在平整坚固的地面上，整机调平状态下起重机的额定起重量。
2. 起重性能表中工作幅度是指吊载后的实际幅度。
3. 起重性能表中额定起重量包括起重钩（主起重钩重 551kg，副起重钩重 100kg）和吊具的重量。
4. 打开好第五支腿时，表中数值适用于全方位（360°）作业。
5. 使用臂尖滑轮时额定起重量不超过 5000kg。若副起重臂处于展开状态，主臂起吊的额定起重量应减少 2300kg。
6. 如果实际臂长和幅度介于两个数值之间时，取较长的臂长及较大的幅度所决定的额定起重量进行起吊作业。



SANY GROUP CRANE BU

SANY Mobile Crane Industrial Park, No.168 Jinzhou Avenue, Jinzhou Development Zone, Changsha City,
Hunan Province, P.R. China Zip 410600
Consulting sanycrane@sanygroup.com (Crane BU) / crd@sany.com.cn (IHQ)
After-sales Service 0086-400 6098 318

Reminder:
Any change in the technical parameters and configuration due to product modification or upgrade may occur without prior notice.
The machine in the picture may include additional equipment. This brochure is for reference only, and goods in kind shall prevail.
Copyright at SANY. No part of this brochure may be copied or used for any purpose without written approval from SANY.

© Edited in March 2024

三一集团起重事业部

中国湖南长沙金洲开发区金洲大道 168 号 三一汽车起重机产业园 邮编: 410600
咨询: sanycrane@sanygroup.com (起重事业部) / crd@sany.com.cn (国际总部)
海外售后服务: 0086-400 6098 318

温馨提示:
由于技术不断更新, 技术参数及配置如有更改, 恕不另行通知。图中机器可能包括附加设备, 本画册仅供参考, 以实物为准。
版权为三一所有, 未经三一书面许可, 本画册任何内容不得被复制用于任何目的。

© 2024 年 3 月版

