

# SPS 17500 STIFF BOOM CRANE

IDEAL LIFTING SOLUTION FOR 2 & 3 AXLE TRUCKS



# TECHNICAL SPECIFICATIONS

## Product Description

- SANY PALFINGER produces according to European Quality Standards to ensure reliability, performance and safety in the industry
- High tensile strength extension booms to optimize lifting height and working range
- The wide outrigger span ensures stability in all mounting situations
- High safety factor with greater reliability
- Piston pump option for reliability, efficiency, and extended lifetime
- Standard package includes
  - Emergency stop button
  - Working light
  - High pressure filter
  - Over-winding stop

## Technical Data

Basic Data	SPS 17500B
Rated Lifting Moment	19.8 mt
Rated lifting capacity	8000 kg (2.0m)
Max. outreach	13.5m
Max. lines of the hook	4
Slewing angle	Continuous
Boom raising angle	0 ~ 75°
Max. lifting height (the measurement from the ground after the outriggers fully extended)	15.3 m
Length of the boom system (retracted)	4.8 m
Length of the boom system (fully extended)	13.8 m
Boom sections	4
Outrigger span (fully extended)	5600 (mm)
Recommended Flow Rate	45 - 70 L/min
Operating pressure	28 Mpa
Recommended oil tank capacity	100 L
Crane moment (dynamic)	301.1 kNm 30.7 mt
Torsional moment (dynamic)	19.2 kNm 2.0 mt
Crane Weight	2730 kg (Floor Control)

# LIFTING CHART

SPS 17500B

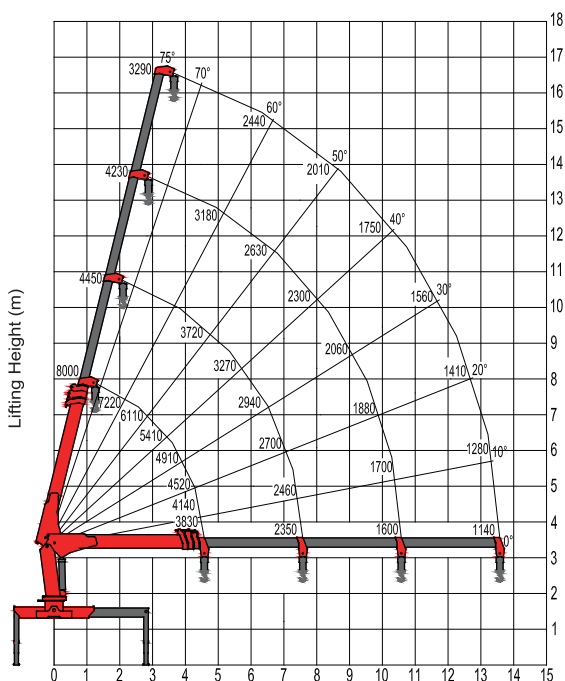

## NOTE

The above lifting height and boom angles are based on a straight (unladen) boom. Allowance should be made for boom deflection under laden conditions. Lifting capacities must not exceed 85% of tipping load.



# CRANE DIMENSION

SPS17500B-F

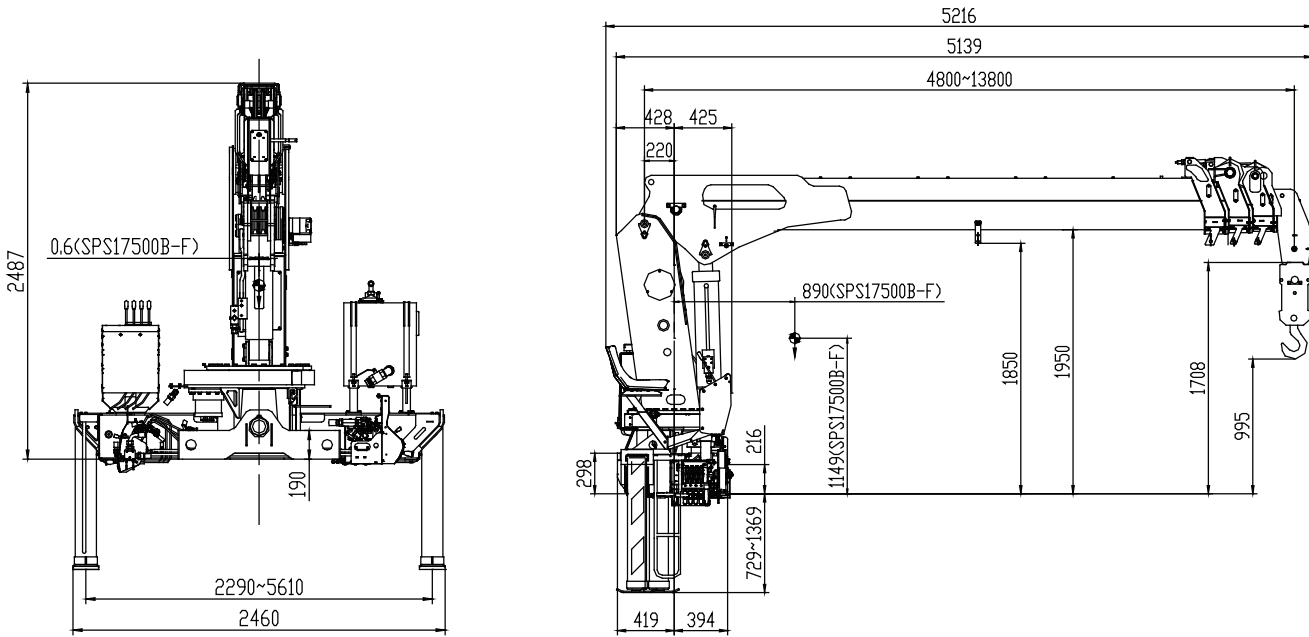

\*The actual product dimensions can vary depending on the operational equipment.

# FEATURES & OPTIONS

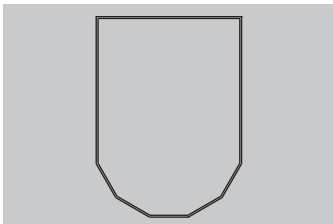

## Octagonal Boom Profile

- High strength and rigidity due to octagonal cross section



## High Tensile Steel

- High Tensile Steel: HG785, SC960
- Able to withstand higher forces



## Overload Protection System

- Built-in safety function
- Protects the crane against overloading



## Working Light

- Safer operations in dusty and dark working conditions
- Optimal visibility for work



## High Pressure Filter

- Ensures proper functionality and longer lifetime of crane



## Proportional Hydraulic System

- Sensitive and stable controls for precise operation
- Operator is able to utilize multiple functions simultaneously



## Load Indicator

- Provides operators with important information on possible overloading and lifting conditions

SANYPALFINGER SPV EQUIPMENT CO.,LTD  
Huanghe Road 189,Rudong Economic Development Zone  
226499,Nantong,China  
T: 4008-835-318  
[www.sanypalfinger.com](http://www.sanypalfinger.com)



Cranes shown in the leaflet are partially optional equipped and do not always correspond to the standard version. Country-specific regulations must be observed. Dimensions may vary. Subject to technical changes, errors and translation mistakes.