



Quality Changes The World

SLT315(T6031-18)

SANY Tower Crane
三一重工塔式起重机



Better World Better SANY Crane

SANY CRANE





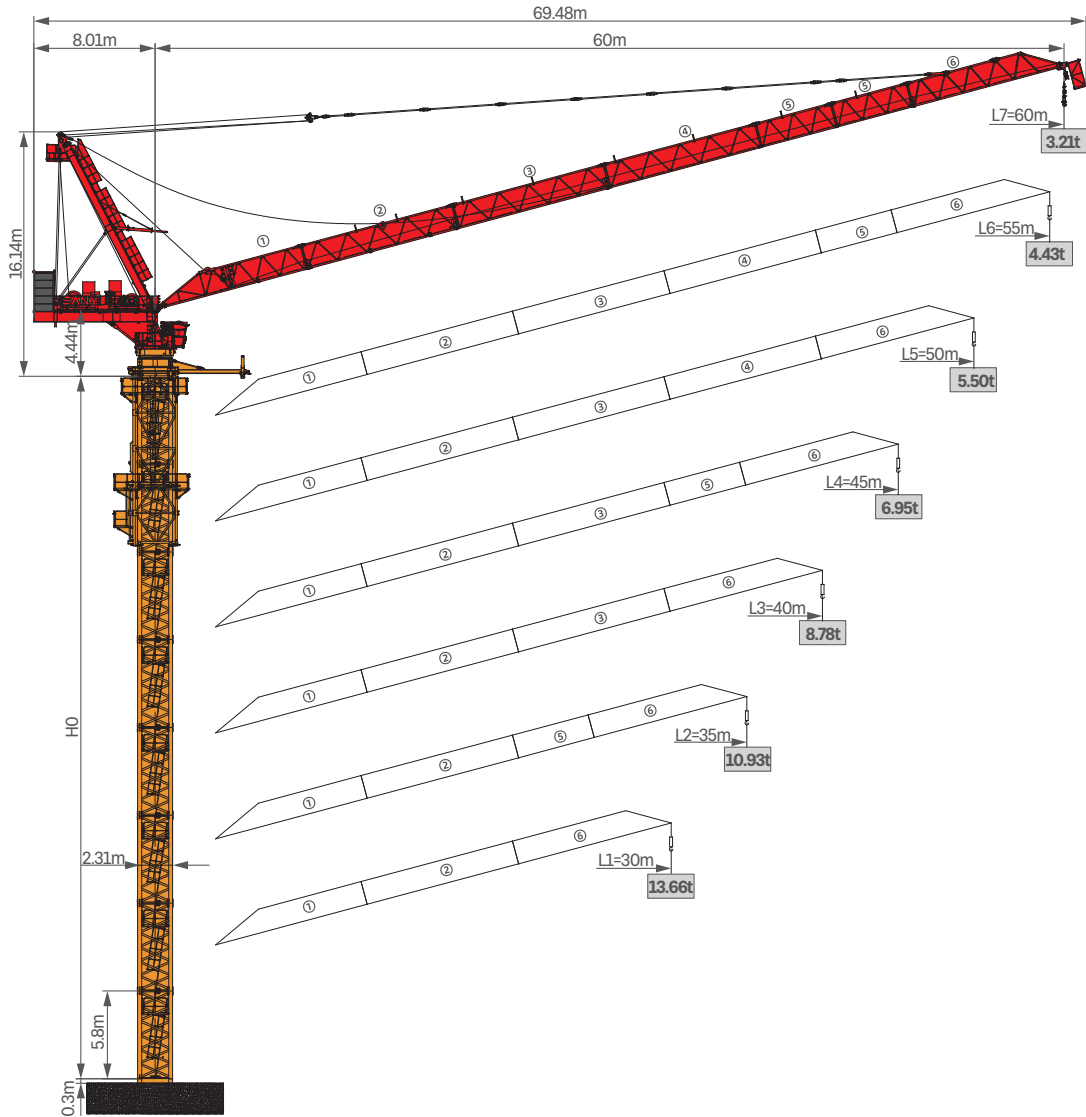



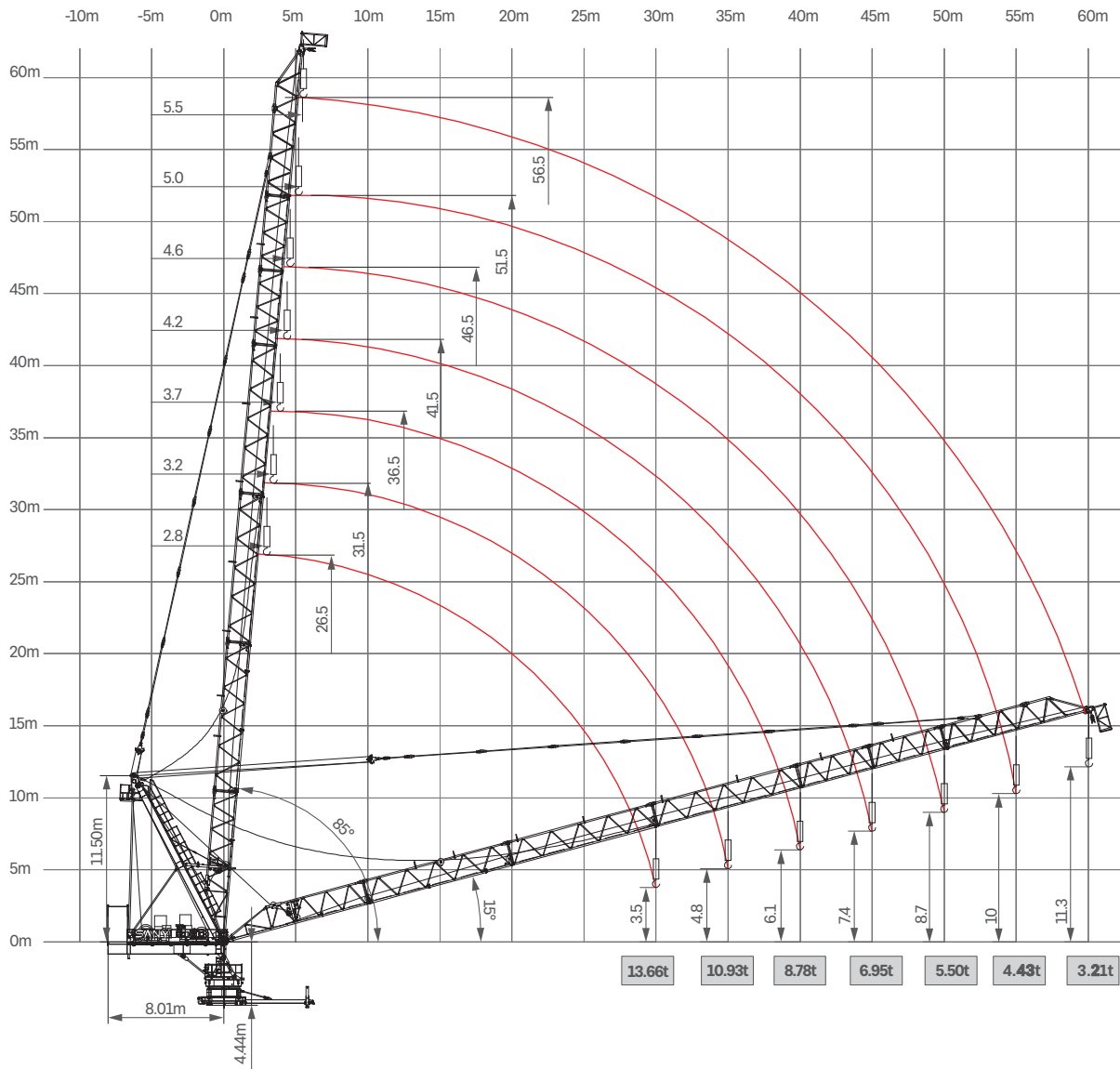

















Jib Length & Tip Load 臂长组合及吊重 (2.31×2.31×5.8)









luffing 变幅



Load Diagrams 起重特性表

radius/m 幅度 (m)	the max. capacity/t 最大起重量	15	20	25	30	35	40	45	50	55	60
60	 5.5-52.8/4.5t	4.50	4.50	4.50	4.50	4.50	4.50	4.50	4.50	4.07	3.21
	 5.5-36.3/9t	9.00	9.00	9.00	9.00	9.00	7.62	6.11	4.90	3.91	3.10
55	 5.0-54.7/4.5t	4.50	4.50	4.50	4.50	4.50	4.50	4.50	4.50	4.43	
	 5.0-37.2/9t	9.00	9.00	9.00	9.00	9.00	7.96	6.45	5.24	4.26	
50	 5.0-27.5/13.5t	13.50	13.50	13.50	12.31	9.73	7.79	6.29	5.10	4.15	
	 4.6-50.0/4.5t	4.50	4.50	4.50	4.50	4.50	4.50	4.50	4.50		
	 4.6-37.8/9t	9.00	9.00	9.00	9.00	9.00	8.21	6.70	5.50		
	 4.6-28.5/13.5t	13.50	13.50	13.50	12.56	9.98	8.04	6.55	5.37		
45	 4.6-22.9/18t	18.00	18.00	15.99	12.38	9.80	7.88	6.40	5.25		
	 4.2-45.0/4.5t	4.50	4.50	4.50	4.50	4.50	4.50	4.50			
	 4.2-38.4/9t	9.00	9.00	9.00	9.00	9.00	8.45	6.95			
	 4.2-28.8/13.5t	13.50	13.50	13.50	12.80	10.22	8.29	6.82			
40	 4.2-23.0/18t	18.00	18.00	16.23	12.62	10.05	8.14	6.68			
	 3.7-40.0/4.5t	4.50	4.50	4.50	4.50	4.50	4.50				
	 3.7-39.3/9t	9.00	9.00	9.00	9.00	9.00	8.78				
	 3.7-29.3/13.5t	13.50	13.50	13.50	13.14	10.56	8.64				
35	 3.7-23.4/18t	18.00	18.00	16.57	12.96	10.40	8.50				
	 3.2-35.0/4.5t	4.50	4.50	4.50	4.50	4.50					
	 3.2-35.0/9t	9.00	9.00	9.00	9.00	9.00					
	 3.2-29.9/13.5t	13.50	13.50	13.50	13.50	10.93					
30	 3.2-23.7/18t	18.00	18.00	16.93	12.33	10.79					
	 2.8-30.0/4.5t	4.50	4.50	4.50	4.50						
	 2.8-30.0/9t	9.00	9.00	9.00	9.00						
	 2.8-30.0/13.5t	13.50	13.50	13.50	13.50						
	 2.8-24.1/18t	18.00	18.00	17.23	13.66						

Counter-jib Ballast 平衡臂及平衡重组合表

 (m)	 (m)	 (kg)	 (5000kg T-shape counter)	 (5000kg -shape counter)	 (5000kg※-shape counter)
60	8.0	30000	1	4	1
55	8.0	30000	1	4	1
50	8.0	30000	1	4	1
45	8.0	30000	1	4	1
40	8.0	30000	1	4	1
35	8.0	30000	1	4	1
30	8.0	30000	1	4	1

Counter weight with ※ is without protruding bolck
带 ※ 配重无凸起方块

Masts 塔身 SH205C (2.31×2.31×5.8)

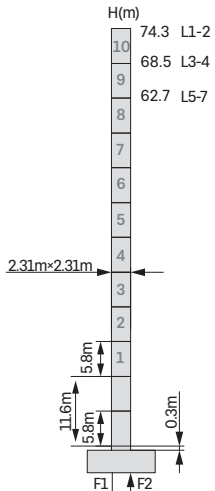

(Fixing tower) 固定式塔身

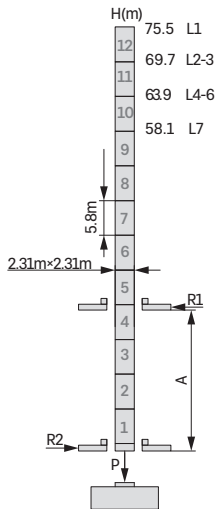

(Crawling tower) 内爬式塔身

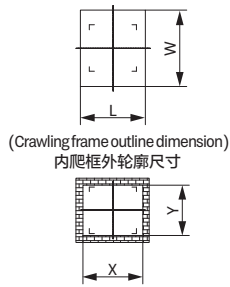

(Crawling frame outline dimension) 内爬框外轮廓尺寸

(Crawling frame opening dimension) 内爬开口尺寸

F1	Reactions in service 工作状态反力	253t
	Reactions out of service 非工作状态反力	485t
F2	Reactions in service 工作状态反力	188t
	Reactions out of service 非工作状态反力	426t
Freestanding height, dead weight at the max. jib (without counter weight, lifting weight nor ballast) 独立高度, 最长起重臂时自重(不含平衡重、吊重、压重)		108.4t

jib length 臂长 (m)	H 高 (m)	mark 符号
30m	74.3	L1
35m	74.3	L2
40m	68.5	L3
45m	68.5	L4
50m	62.7	L5
55m	62.7	L6
60m	62.7	L7

Hmax=250m L=3.50m W=3.02m X=3.28m Y=2.40m				
mark 符号	P	A	R1	R2
L1	159.1t	23.2m	77.6t	49.3t
L2	154.2t	23.2m	83.5t	52.8t
L3	154.9t	23.2m	77.7t	49.4t
L4	150.0t	17.4m	92.3t	63.2t
L5	150.5t	17.4m	99.5t	69.7t
L6	146.4t	17.4m	103.8t	73.4t
L7	136.6t	17.4m	93.9t	65.1t

jib length 臂长 (m)	H 高 (m)	mark 符号
30m	75.5	L1
35m	69.7	L2
40m	69.7	L3
45m	63.9	L4
50m	63.9	L5
55m	63.9	L6
60m	58.1	L7

Anchorage 附着 (2.31×2.31×5.8)

JIB L7 2.31 × 2.31※

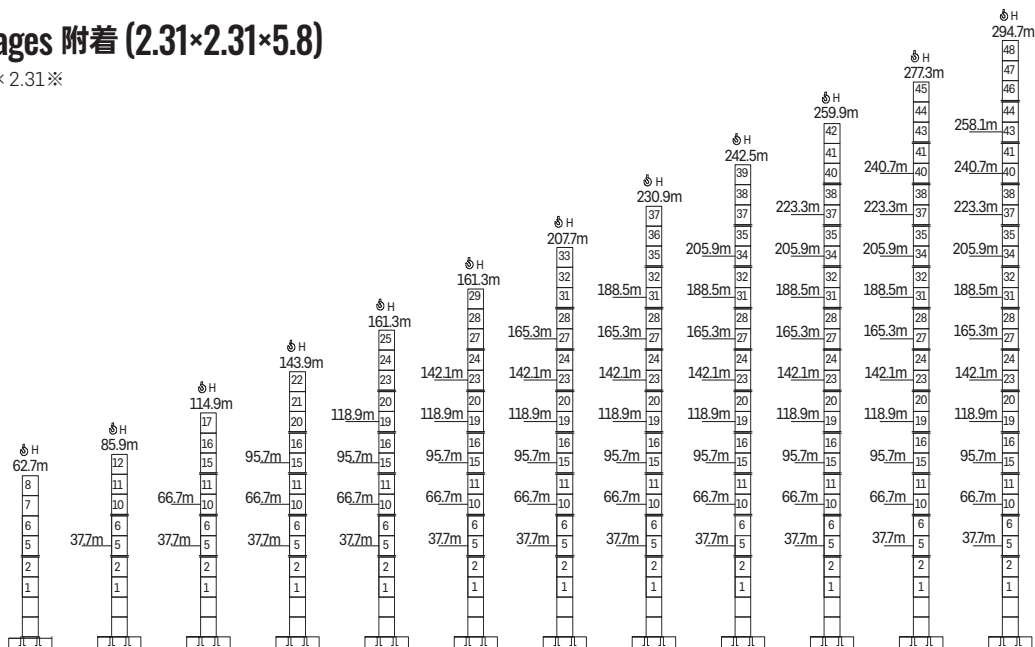

Masts 塔身 H20 (1.95×1.95×3.75)

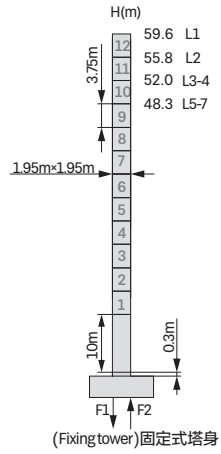

F1	Reactions in service 工作状态反力	257t
	Reactions out of service 非工作状态反力	373t
F2	Reactions in service 工作状态反力	203t
	Reactions out of service 非工作状态反力	322t
Freestanding height, dead weight at the max. jib (without counter weight, lifting weight nor ballast) 独立高度, 最长起重臂时自重 (不含平衡重、吊重、压重)		79.2t

jib length 臂长 (m)	H 高 (m)	mark 符号
30m 59.6 L1	59.6	L1
35m 55.8 L2	55.8	L2
40m 52.0 L3	52.0	L3
45m 52.0 L4	52.0	L4
50m 48.3 L5	48.3	L5
55m 48.3 L6	48.3	L6
60m 48.3 L7	48.3	L7

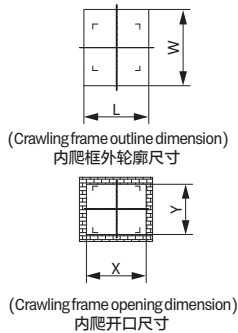
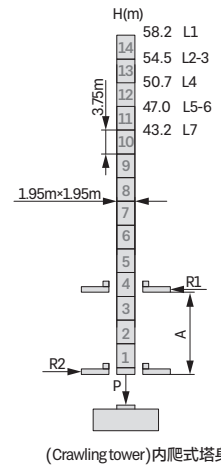

Hmax=250m L=3.50m W=3.02m X=3.28m Y=2.40m				
mark 符号	P	A	R1	R2
L1	133.9t	11.3m	86.5t	58.3t
L2	131.5t	11.3m	85.7t	57.9t
L3	132.3t	11.3m	95.0t	66.2t
L4	129.9t	11.3m	90.1t	63.5t
L5	127.5t	11.3m	90.1t	62.9t
L6	123.3t	11.3m	94.9t	67.0t
L7	116.1t	11.3m	91.4t	64.5t

jib length 臂长 (m)	H 高 (m)	mark 符号
30m	58.2	L1
35m	54.5	L2
40m	54.5	L3
45m	50.7	L4
50m	47.0	L5
55m	47.0	L6
60m	43.0	L7

Anchorage 附着 (1.95×1.95×3.75)

JIB L7 H20※

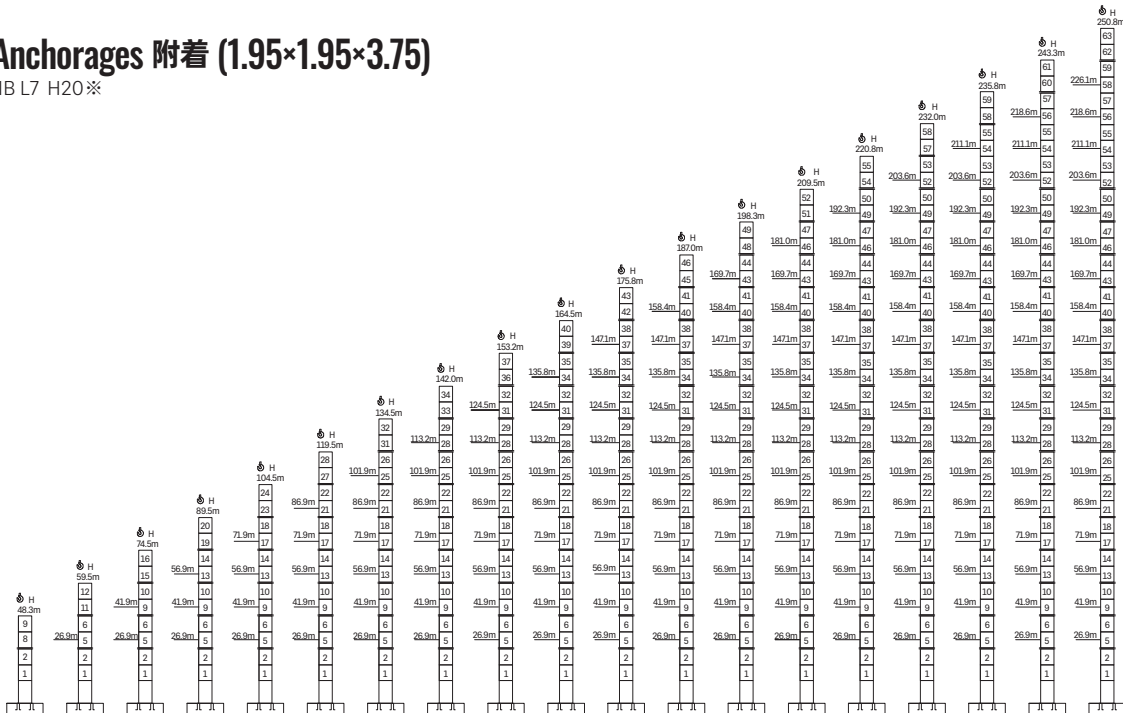

Transmission Mechanisms 传动机构

Transmission 传动	Legend 图例	Model 型号	Power 功率	Velocity 速度
Slewing 回转		YPWEF160M-4F1 YPWEF160M-4F1B	2 × 11kW	0-0.8r/min
Trolleying 变幅		YZTP250M3-4	55kW	≤2.2min
Hoisting 起升		YZTPF180L3-4	75kW	0-153m/min
Voltage 电源电压		380V(±10%), 50Hz/60Hz; 400V(±10%), 50Hz/60Hz		

Note: Contact with us when the rope capacity of hoisting mechanism is larger than 500m.
注: 工作容绳量大于 500m 时请与厂家联系

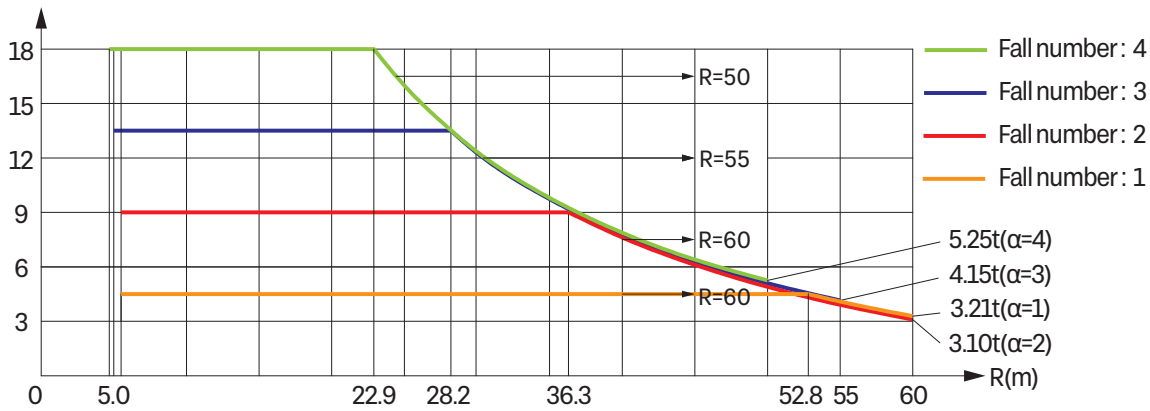

Curve of Lifting Capacity 起重性能曲线图



Packing List 运输部件

NO. 序号	Description 名称	Sketch 形状	L(m) 长	B(m) 宽	H(m) 高	Weight per unit (t) 单件重量 (t)	Quantity 数量
1	Jib section I 臂架 I		10.56	1.76	1.91	1.849	1
2	Jib section II 臂架 II		10.51	1.72	1.71	1.236	1
3	Jib section III 臂架 III		10.51	1.72	1.71	1.248	1
4	Jib section IV 臂架 IV		10.51	1.72	1.71	1.059	1

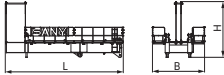
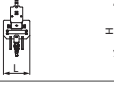
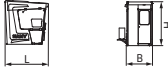
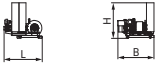
Packing List 运输部件

NO. 序号	Description 名称	Sketch 形状	L(m) 长	B(m) 宽	H(m) 高	Weight per unit (t) 单件重量 (t)	Quantity 数量
5	Jib section V 臂架 V		5.34	1.72	1.71	0.592	2
6	Jib section VI 臂架 VI		10.60	1.72	2.62	1.665	1
7	A frame assembly A架总成		11.60	2.58	8.14	5.916	1
8	Counter jib strut 平衡臂撑杆		2.52	0.25	1.84	0.618	1
9	Counter jib 平衡臂		8.36	3.69	3.74	6.249	1
10	Hook 吊钩		1.20	0.62	2.47	0.692	1
11	Cabin 司机室		2.28	1.41	2.18	0.400	1
12	Hoisting mechanism 起升机构		2.70	2.54	2.39	4.768	1
13	Luffing mechanism 拉臂机构		3.09	2.37	2.39	4.745	1
14	Lampstand 三角架		1.75	2.13	1.67	1.308	1
15	Upper support 上支座		4.62	2.73	1.69	4.114	1
16	Lower support 下支座		8.05	3.05	1.50	6.492	1
17	Telescoping cage 爬升架		11.50	4.53	4.96	12.387	1
18	Standard mast 标准节		6.11	2.31	2.31	5.625	8
19	Basic mast 基础节		6.11	2.31	2.31	6.198	2
16*	Lower Support 下支座		7.06	2.82	1.50	2.892	1
17*	Telescoping cage 爬升架		9.81	3.41	4.86	7.470	1
18*	Standard mast 标准节		4.11	1.95	1.95	2.995	9
19*	Basic mast 基础节		10.35	1.95	1.95	7.000	1

* is another configuration of tower mast.

*表示另一种塔身配置。



SANY GROUP CRANE BU

SANY Tower Crane Industrial Park, No.168 Jinzhou Avenue, Jinzhou Development Zone, Changsha City,
Hunan Province, P.R. China Zip 410600
Consulting sanycrane@sanygroup.com (Crane BU) / crd@sany.com.cn (IHQ)
After-sales Service 0086-400 6098 318

Reminder:

Any change in the technical parameters and configuration due to product modification or upgrade may occur without prior notice. The machine in the picture may include additional equipment. This brochure is for reference only, and goods in kind shall prevail.

Copyright at SANY. No part of this brochure may be copied or used for any purpose without written approval from SANY.

©Edited in November 2022 v1.0

三一集团起重事业部

中国湖南长沙金洲开发区金洲大道168号三一塔式起重机产业园 邮编: 410600
咨询: sanycrane@sanygroup.com (起重事业部) / crd@sany.com.cn (国际总部)
海外售后服务: 0086-400 6098 318

温馨提示:

由于技术不断更新, 技术参数及配置如有更改, 恕不另行通知。图中机器可能包括附加设备, 本画册仅供参考, 以实物为准。
版权为三一所有, 未经三一书面许可, 本画册任何内容不得被复制用于任何目的。

© 2022 年 11 月版

SANY CRANE



www.sanyglobal.com

