



SCI2600A

Crawler Crane

260 Tons Lifting Capacity

Quality Changes the World



- Max. lifting moment: $230 \times 6 = 1380 \text{t} \cdot \text{m}$
- Max. boom length: 85m
- Max. fixed jib combination: 70m+31m
- Max. luffing jib combination: 55m+58m

The parameters, pictures and standard/optional equipment are only for reference in this brochure, the actual machine is based on the effective price list and contract.



Crawler Crane Series SCI2600A

P03

Main
Characteristics

- Product Specification
- Safety Device

P09

Technical
Parameters

- Major Performance & Specifications
- Outline Dimension
- Transport Dimension
- Transport Plan

P19

Configurations

- H Configuration
- FJ Configuration
- LJ Configuration



SCI2600A
SANY CRAWLER CRANE
260 TONS LIFTING CAPACITY

QUALITY CHANGES THE WORLD

Main Characteristics

- Page 04 Product Specification
- Page 07 Safety Device



Product Specification



Engine

- Model: QSL8.9-C325, Chinese Cummins, Diesel engine;
- Type: 4-stroke, water-cooled, vertical in-line 6 cylinders, direct injection, turbo-charger, intercooler, complied with European Non-road Tier III Emission Standard and Chinese Non-road Tier III Emission Standard;
- Displacement: 8.9L;
- Rated power: 242kW/2100rpm;
- Operation power: 234kW/1800rpm;
- Max. Torque: 1385N·m/1500rpm;
- Starter: 24V-6.0kW;
- Radiator: fin type aluminum plate core;
- Air cleaner: Dry type system with main filter element, safety element and resistance indicator;
- Throttle: Grip type hand throttle, electrically-controlled;
- Fuel filter: Replaceable paper element;
- Batteries: Two 12V×180Ah capacity batteries, connected in series;
- Fuel tank capacity: 400L.

Electrical Control System

- Self-developed SYIC-II integrated control system is adopted with higher integration, precise operation and reliable quality;
- Control system consists of power system, engine system, main control system, LMI system, auxiliary system and safety monitoring system. CAN BUS is used for data communication between controller, monitor and the engine;
- Monitor: the working parameters and status are shown on the monitor, such as the engine speed, fuel volume, engine oil pressure, servo pressure, engine working hours, lifting conditions and boom angle.

Hydraulic System

- Main pumps: open variable displacement piston pumps of large displacement are adopted to provide oil supply for main actuators of main machine;
- Gear pump: dual gear pump for swing, radiator and control circuit;
- Control: main pump adopts electrically-controlled positive flow control; winch motor adopts limitless adjustable piston motor of variable displacement. The operating components are two cross hydraulic handle, one dual travel pedal control valve to control various actuators proportionally;
- Way of cooling: heat exchanger, fan core and multi-stage cooling;
- Filter: large flow, high precision filter, with bypass valve and transmitter, which can remind the user to replace the filter element in time;
- Max. pressure of system: 32Mpa;
- Main/aux. load hoist, boom hoist and travel system: 32Mpa;
- Swing system: 25Mpa;
- Control system: 4.5MPa;
- Hydraulic Tank Capacity:460L.

Main and Auxiliary Load Hoist Mechanism

- Main and aux. hoist winches are driven separately by motor via gearbox. Operating winch handle can control the winch to rotate to two directions, which are lifting and lowering of hook. Excellent inching function is equipped on the machine;
- Drums with fold-line grooves can ensure the wire rope reeved in order in multilayers.

Main Hoisting Mechanism	Drum diameter	630mm
	Rope speed (5th layer)	0-145m/min
	Diameter of wire rope	26mm
	Main load hoist wire rope length	430m
	Rated single line pull	13.5t
Auxiliary Hoisting Mechanism	Drum diameter	630mm
	Rope speed (5th layer)	0-130m/min
	Diameter of wire rope	26mm
	Auxiliary load hoist wire rope length	310m
	Rated single line pull	13.5t



Product Specification

Boom Hoist Mechanism

- Boom hoist winch is driven directly by motor via gearbox. Operating winch handle can control the winch to rotate to two directions, which are lifting and lowering of boom;
- Drums with fold-line grooves can ensure the wire rope reeved in order in multilayers.

Boom hoist mechanism	Drum diameter	440mm
	Rope speed (5th layer)	0-67m/min
	Diameter of wire rope	22mm
	Boom hoist wire rope length	250m
Jib hoist mechanism	Drum diameter	500mm
	Rope speed (5th layer)	0-67m/min
	Diameter of wire rope	22mm
	Jib hoist wire rope length	190m

Swing Mechanism

- Swing brake adopts wet, spring loaded, normally-closed brake, and braking through spring force;
- Swing system, has free slipping function. It is featured in steady starting and control, and excellent inching function. Unique swing buffer design and steadier brake;
- Swing drive: external engaged swing drive with 360° swing range, and the max. swing speed is 1.5r/min. The max. drive pressure can reach 25 MPa;
- Swing ring: three-row roller bearing.

Cab and Control

- Novel operator's cab with fashionable profile, nice interior and large window glass, which can tilt up by 20° to provide panorama view. There are low and high-beam lights, back-view mirror, heater and A/C, radio and other functions. The layout of seat, handles, control buttons are designed with ergonomic principles to make operation more comfortable;
- Cab layout: Integrated 10.4-inch touch screen, programmable smart switches, and man-machine interaction interface are more perfect;
- Armrest box: on the left and right armrest box are control handles, electrical switches, emergent stop and ignition switch. The armrest box can be adjusted along with the seat;
- Seat: multi-way and multi-level floating adjustable seat with unload switch;
- A/C: cool and heat air; optimized air channels and vents;
- Multiple cameras can present on the monitor at the same time to realize backing video, real-time monitoring of wire rope on each winch, conditions behind the counterweight and surrounding the machine.

Counterweight

- The stacking mode of counterweight tray and blocks is used for easy assembly, disassembly and transportation;
- Rear counterweight: total 80t, 6t×10, 3t×2, counterweight tray 14t;
- Rear counterweight self-assembly device is offered as optional;
- Carbody counterweight: total 25t, 12.5t x 2.

Upperworks

- High-strength steel weld framework, with no torsion or deformation. The parts are laid out in the way that is easier for maintenance and service.

Product Specification



Lowerworks

- Independent travel driving units are adopted for each side of the crawler, to realize straight walking and turning driven by travel motor through gearbox and drive wheel.

Crawler Tightening

- The jack is used to push the guide wheel and insert the shim to adjust crawler tension.

Track Pad

- High strength alloy cast steel track pad ensure long service life;
- They are 1100mm wide with a quantity of 59 pads x 2.

Operating Equipment

- All chords are high-strength steel tubes, and the boom/jib top sheaves are made of high-strength anti-wearing Nylon material protecting wire rope. The hooks are installed with milled welded steel sheave.

Boom

- Lattice structure. The chord adopts high-strength structural tube and each section is connected through pins;
- Basic boom: 8m boom base + 8m boom top;
- Boom insert: 3m×1, 6m×3, 12m×4;
- Boom length: 16m~85m.

Fixed Jib

- Lattice structure. The chord adopts high-strength structural tube and each section is connected through pins;
- Basic jib: 5m jib base +3m insert +5m jib top;
- Jib insert: 6m×3;
- Fixed jib: 13m~31m;
- Longest boom + jib: 70m +31m.

Luffing jib

- Lattice structure. The chord adopts high-strength structural tube and each section is connected through pins;
- Basic jib: 6.5m jib base +9m insert +6.5m jib top;
- Jib insert: 3m×1,6m×1,9m×3;
- Longest boom + jib: 55m+58m.

Extension Jib

- The welding structure is connected with main boom through hinge pin, and used for aux. hook operation;
- Length of extension jib: 1.5m.

Hook Block

- 250t hook, 11 pulleys
- 150t hook, 7 pulleys;
- 80t hook, 3 pulleys;
- 35t hook, 1 pulley;
- 13.5t ball hook.



Safety Device

Assembly/Work Mode Control Switch

- Under the assembly mode, over-hoist limit switch, crane boom limit device and load moment limiter do not work, so as to facilitate the installation of crane;
- All safety limit devices work in the work mode.

Emergency Stop

- In emergent situation, this button is pressed down to cut off the power supply of whole machine and all actions stop.

Load Moment Limiter (LMI)

- It is an independent computerized safety control system. LMI can automatically detect the load weight, work radius and boom angle, and present on the display the rated load, actual load, work radius and boom angle. In normal operation, the LML can make a judgment and cut off automatically if the crane moves towards dangerous direction. It can also perform as a black box to record the lifting information;
- It is composed of monitor, angle sensor and force sensor and other parts.

Over-hoist Limit Switch of Main/Auxiliary Hooks

- Over-hoist protection device comprises of limit switch and weight on boom top, which prevents the hook lifting up too much;
- When the hook lifts up to the limit height, the limit switch activates, buzzer on the left control panel sends alarm, failure indicator light starts to flash, and the hook hoisting action is cut off automatically, cut off automatically.

Over-release Limit Switch of Main/Auxiliary Hooks

- It is comprised of activator in the drum and proximity switch to prevent over release of wire rope. When the rope is paid out close to the last three wraps, the limit switch acts, and the system sends alarm through buzzer and show the alarm on the instrument panel, automatically cutting off the winch action.

Function Lock Lever

- If the function lock lever is not in work position, all the other handles won't work, which prevents any mis-operation caused by accidental collision.

Boom Hoist Drum Lock

- Pawl lock is used on boom hoist winch, which needs to unlock by switch before operation, in order to prevent mis-operation of handles and ensure safety during nonwork time.

Swing Lock Device

- Swing Lock can lock the machine at four positions, front and back, left and right.

Boom Limit Device

- When the boom elevation angle reaches the max. set limit, the buzzer sounds and boom action cut off. This protection is two-stage control ensured by both LML system and travel switch.

Back-stop Device

- Its major components are nesting tubes and spring, in order to buffer the boom backlash and prevent further tipping back.

Boom Angle Indicator

- Pendulum angle indicator is fixed on the side of boom base close to the cab, so as to provide convenience to the operator.

Hook Latch

- The hook is provided with a baffle to prevent wire rope from falling off.

Safety Device



Lightning Protection Device

- It is offered as an optional feature, which includes the grounding device that can effectively protect the electric system elements and workers from lightning.

Tri-color Load Indicator

- The load indication light has three colors, green, yellow and red, and the real time load status is presented on the display. When the actual load is smaller than 90% of rated load, the green light is on;
- When the actual load is larger than 90% and smaller than 100%, the yellow light is on, the alarm light flashes and sends out intermittent sirens;
- When the actual load reaches 100% of rated load, the red light is on, the alarm light flashes and sends out continuous sirens;
- When the actual load reaches 102% of rated load, the system will automatically cut off the crane operation in dangerous trend.

Audio-visual Alarm

- When the engine is working, the light flashes; when the machine is traveling or swinging, it sends out sirens.

Swing Indicator Light

- The swing indicator light flashes during traveling or swing.

Illuminating Light

- The machine is equipped with the low beam light and high beam light at the front of the cab, illumination light at cab, and other night lights, boom lights to improve the visibility during construction.

Camera

- Set on the handrail at the front of right sheet metal, so as to monitor the rear part of machine.

Pharos

- Pharos is mounted on the top of boom/jib to indicate the height.

Anemometer

- It is mounted on the top of boom/jib, and displayed on the monitor in the cab.

Electronic Level Indicator

- It displays the tipping angle of crane on the monitor in real time, protecting the machine from dangerous situation.

Seat Interlock

- Put down the function lock lever on the left side of cab seat or if the operator leaves the seat, all control levers will be deactivated to prevent any mis-operation due to accidental collision.

Engine Power Limit Load Adjustment and Stalling Protection

- The controller monitors the engine power to prevent engine getting stuck and stalling.

Engine Status Monitoring

- The engine status will be presented, such as engine coolant temperature, fuel volume, total work hours, engine oil pressure, engine speed, battery charging, voltage.



SCI2600A
SANY CRAWLER CRANE
260 TONS LIFTING CAPACITY

QUALITY CHANGES THE WORLD

Technical Parameters

- Page 10 Major Performance Specifications
- Page 11 Outline Dimension
- Page 12 Transport Dimension
- Page 17 Transportation Plan



Major Performance Specifications

Major Performance & Specifications of SCI2600A			
Performance Indicators		Unit	Parameter
Boom configuration	Maximum rated lifting capacity	t	260
	Maximum rated lifting moment	t·m	1380 (=230×6)
	Boom length	m	16~85
Fixed jib configuration	Maximum rated lifting capacity	t	36.3
	Jib length	m	13~31
	Longest main boom + fixed jib	m	70+31
LJ configuration	Maximum rated lifting capacity	t	66.8
	Jib length	m	22~58
	Longest boom + luffing jib	m	55+58
Operation speed	Rope speed of main/aux. load hoist (5th layer)	m/min	0-130
	Rope speed of boom/jib hoist (5th layer)	m/min	0-67
	Slewing speed	rpm	0-1.5
	Travelling speed	km/h	0-1.0
Engine	Model/displacement	/L	QSL8.9/8.9
	Rated power/speed	kW/rpm	242/2100
Transport parameter	Max. transport weight of basic machine (with boom base)	t	47.3
	Maximum transport dimension of basic machine (L × W × H)	mm	17100×3000×3250
Other parameters	Average ground bearing pressure	MPa	0.119
	Gradeability	%	30

Unit: mm

Outline Dimension

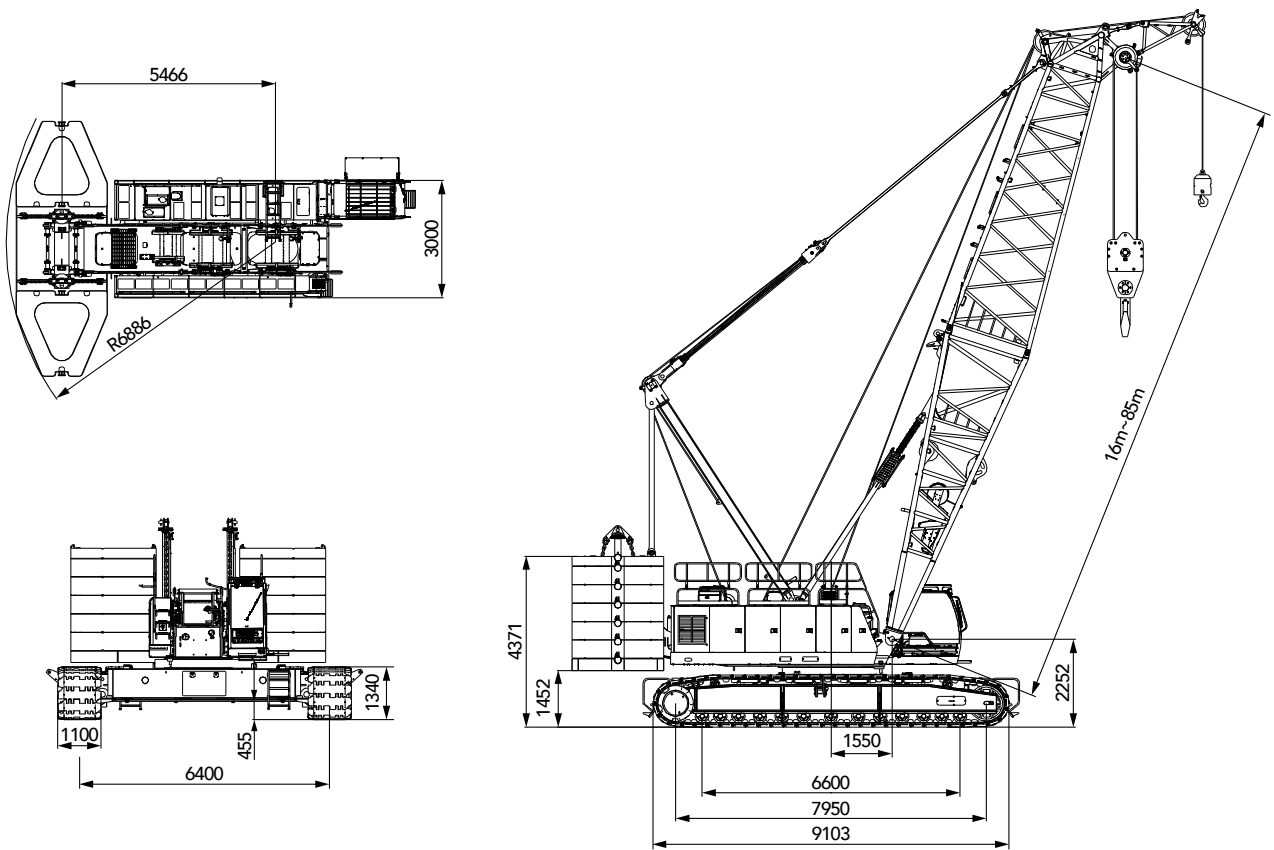

Transportation Dimensions

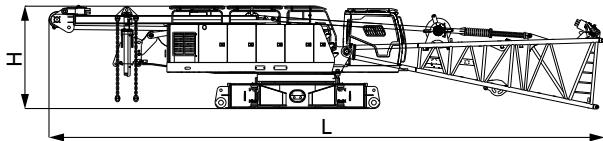

Basic machine

×1

Length(L)	17.10m
Width(W)	3.00m
Height(H)	3.25m
Weight	47.3t

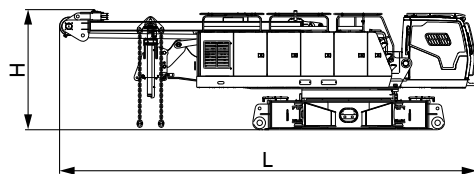

Basic machine 2

×1

Length(L)	11.30m
Width(W)	3.00m
Height(H)	3.25m
Weight	42.8t

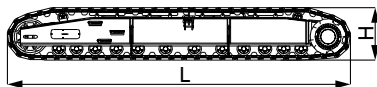

Crawler

×2

Length(L)	9.10m
Width(W)	1.58m
Height(H)	1.34m
Weight	21.2t

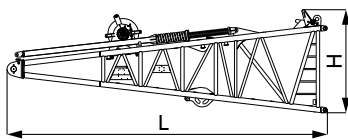

Boom base

×1

Length(L)	8.21m
Width(W)	2.36m
Height(H)	2.51m
Weight	5.93t

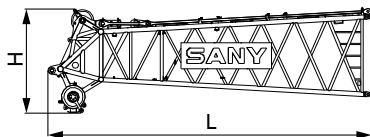

Boom top

×1

Length(L)	8.78m
Width(W)	2.23m
Height(H)	2.92m
Weight	3.6t

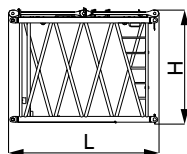

3m boom insert

×1

Length(L)	3.18m
Width(W)	2.23m
Height(H)	2.39m
Weight	0.82t

Transportation Dimensions

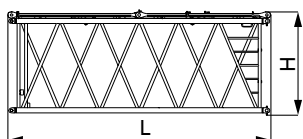

6m Boom insert × 3

Length(L)	6.18m
Width(W)	2.23m
Height(H)	2.39m
Weight	1.31t

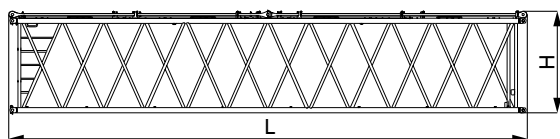

12m Boom insert × 4

Length(L)	12.18m
Width(W)	2.23m
Height(H)	2.39m
Weight	2.43t

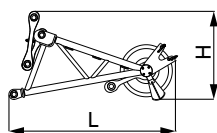

Extension jib × 1

Length(L)	1.96m
Width(W)	0.76m
Height(H)	1.03m
Weight	0.24t

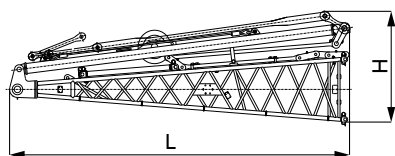

Fixed jib base (with strut and tapered pendant strap) × 1

Length(L)	5.19m
Width(W)	2.16m
Height(H)	1.66m
Weight	1.17t

Note: the weight of the strut is 0.45t, and the tapered pendant strap is 0.15t

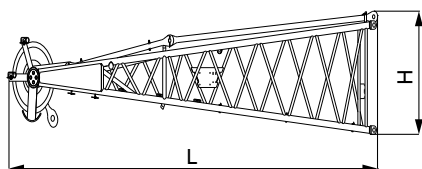

Fixed jib top × 1

Length(L)	5.41m
Width(W)	1.17m
Height(H)	1.06m
Weight	0.59t

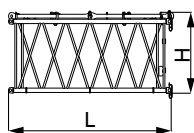

3m fixed jib insert × 1

Length(L)	3.12m
Width(W)	1.17m
Height(H)	1.06m
Weight	0.22t

Transportation Dimensions

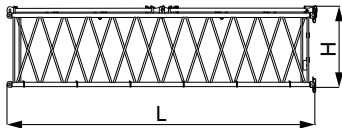

6m fixed jib insert × 3

Length(L)	6.12m
Width(W)	1.17m
Height(H)	1.06m
Weight	0.4t

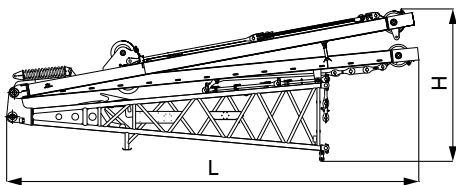

Luffing jib base (with strut) × 1

Length(L)	8.55m
Width(W)	2.19m
Height(H)	3.16m
Weight	4.5t

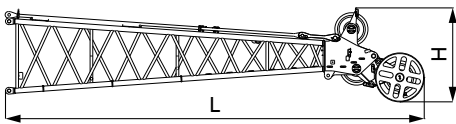

Luffing jib top (with extension jib) × 1

Length(L)	7.75m
Width(W)	1.61m
Height(H)	1.85m
Weight	1.5t

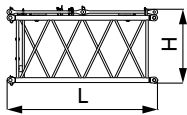

3m luffing jib insert × 1

Length(L)	3.14m
Width(W)	1.61m
Height(H)	1.54m
Weight	0.48t

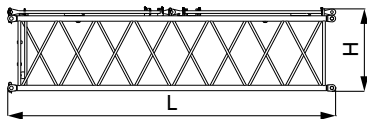

6m luffing jib insert × 1

Length(L)	6.14m
Width(W)	1.61m
Height(H)	1.54m
Weight	0.79t

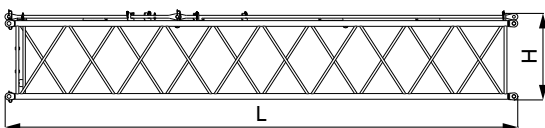

9m luffing jib insert × 4

Length(L)	9.14m
Width(W)	1.61m
Height(H)	1.54m
Weight	1.08t

Transportation Dimensions

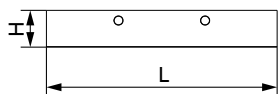

Carbody counterweight × 2

Length(L)	4.95m
Width(W)	1.65m
Height(H)	0.85m
Weight	12.5t

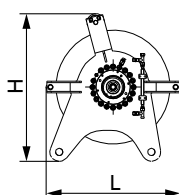

Jib luffing mechanism × 1

Length(L)	0.93m
Width(W)	0.88m
Height(H)	1.03m
Weight	1.25t

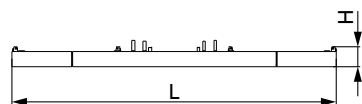

Rear counterweight tray × 1

Length(L)	6.52m
Width(W)	2.33m
Height(H)	0.52m
Weight	14.0t

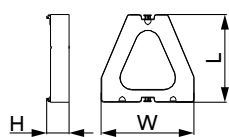

6t counterweight block × 10

Length(L)	2.19m
Width(W)	2.33m
Height(H)	0.57m
Weight	6.0t

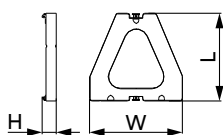

3t counterweight block × 2

Length(L)	2.19m
Width(W)	2.33m
Height(H)	0.35m
Weight	3.0t

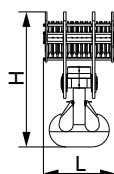

250t hook × 1

Length(L)	1.42m
Width(W)	0.92m
Height(H)	2.67m
Weight	4.48t

Transportation Dimensions

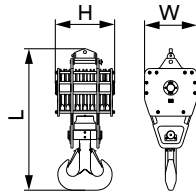

150t hook

×1

Length(L)	2.45m
Width(W)	0.91m
Height(H)	1.03m
Weight	2.91t

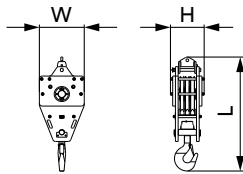

80t hook

×1

Length(L)	2.21m
Width(W)	0.91m
Height(H)	0.62m
Weight	1.94t

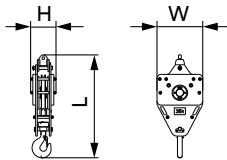

35t hook

×1

Length(L)	1.88m
Width(W)	0.82m
Height(H)	0.46m
Weight	1.11t

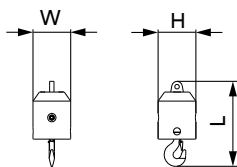

13.5t ball hook

×1

Length(L)	0.95m
Width(W)	0.43m
Height(H)	0.43m
Weight	0.45t

Remarks:

- 1.The transport dimensions for the parts are for reference that do not draw to the scale. The dimensions listed above are design values excluding packing.
- 2.Weight is design values. It may be different due to manufacturing tolerances.

Transport Plan

Transport cart 1	<ul style="list-style-type: none"> 50t low plate-13.5m, Width 3m
Components included	<ul style="list-style-type: none"> Basic Machine (with four winches, carbody assembly, A-frame, wire rope): 41.34t Boom base (include jib hoist winch and jib hoist wire rope): 5.93t Boom base outer pendant strap: 0.03t
Transport weight	<ul style="list-style-type: none"> 47.3t

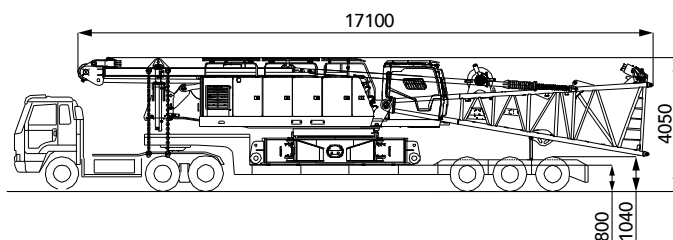

Transport cart 2	<ul style="list-style-type: none"> 35t low plate-17.5m, Width 3m
Components included	<ul style="list-style-type: none"> 12m boom: 2.43t Rear CW tray: 14t Rear CW *2: 12t Luffing jib 9m: 1.08t Tapered pendant strap: 0.15t Fixed jib top: 0.59t Fixed jib 3m: 0.22t 6m boom outer pendant strap: 0.19t
Transport weight	<ul style="list-style-type: none"> 30.66t

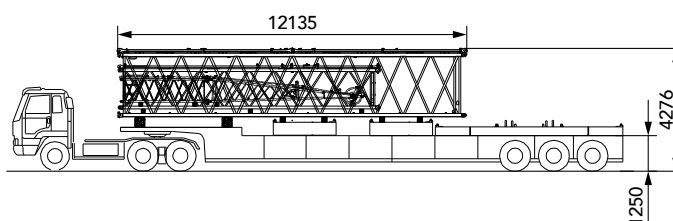

Transport cart 3	<ul style="list-style-type: none"> 35t low plate-17.5m, Width 3m
Components included	<ul style="list-style-type: none"> 12m boom: 2.43t 6m boom: 1.31t Rear CW *4: 24t Luffing jib 9m: 1.08t Fixed jib 6m: 0.4t 12m boom outer pendant strap: 0.34t
Transport weight	<ul style="list-style-type: none"> 29.56t

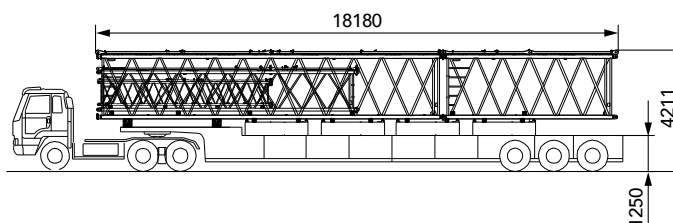

Transport cart 4	<ul style="list-style-type: none"> 35t low plate-17.5m, Width 3m
Components included	<ul style="list-style-type: none"> 12m boom: 2.43t 6m boom: 1.31t Luffing jib 9m: 1.08t Fixed jib 6m: 0.40t Rear CW 6t*4: 24t 35t hook: 1.2t 12m boom outer pendant strap: 0.34t Luffing jib 3m: 0.48t
Transport weight	<ul style="list-style-type: none"> 31.24t

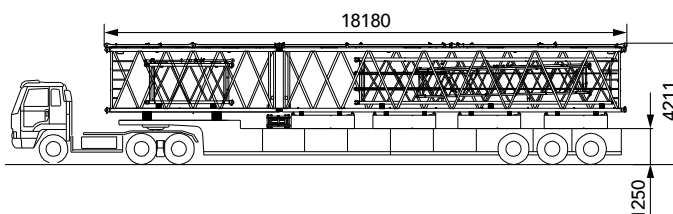

Transport Plan

Transport cart 5	<ul style="list-style-type: none"> 30t low plate-17.5m, Width 3m
Components included	<ul style="list-style-type: none"> Boom base: 3.32t Luffing jib base with mast: 4.5t 150t hook: 2.91t 80t hook: 1.94t 13.5t ball hook: 0.45t Boom base outer pendant strap: 0.24t The packing cases: 1t CW block 3t*2: 6t
Transport weight	<ul style="list-style-type: none"> 20.36t

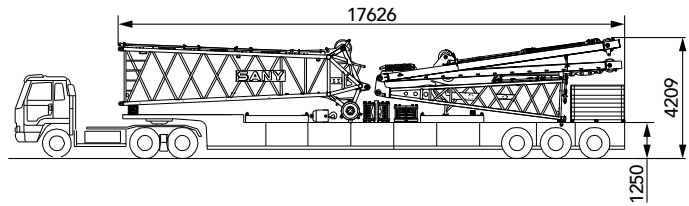

Transport cart 6	<ul style="list-style-type: none"> 30t low plate-17.5m, Width 3m
Components included	<ul style="list-style-type: none"> Right track frame: 21.2t 3m boom: 0.82t 3m boom outer pendant strap: 0.11t Luffing jib 9m: 1.08t Fixed jib 6m: 0.4t 250t hook: 4.48t Extension jib: 0.26t
Transport weight	<ul style="list-style-type: none"> 28.35t

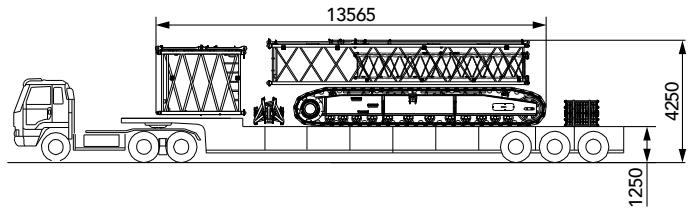

Transport cart 7	<ul style="list-style-type: none"> 30t low plate-17.5m, Width 3m
Components included	<ul style="list-style-type: none"> 12m boom: 2.43t Luffing jib 6m: 0.79t Carbody CW*2: 25t 12m boom outer pendant strap: 0.34t
Transport weight	<ul style="list-style-type: none"> 28.56t

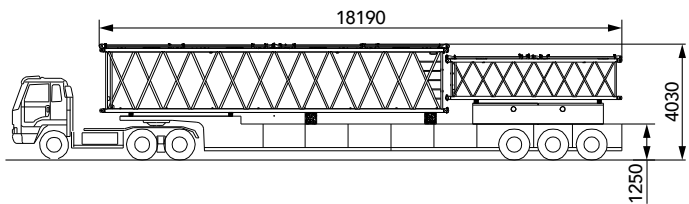

Transport cart 8	<ul style="list-style-type: none"> 30t low plate-17.5m, Width 3m
Components included	<ul style="list-style-type: none"> 6m boom: 1.31t Fixed jib base with struts and no tapered pendant strap: 0.88t Luffing jib top with extension jib: 4.5t Left track frame: 21.2t
Transport weight	<ul style="list-style-type: none"> 27.89t

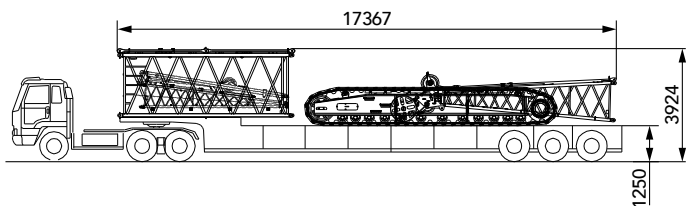

C

SCI2600A SANY CRAWLER CRANE 260 TONS LIFTING CAPACITY

QUALITY CHANGES THE WORLD

Configurations

- Page 23 H Configuration
- Page 29 FJ Configuration
- Page 39 LJ Configuration

> 19

Boom Combination

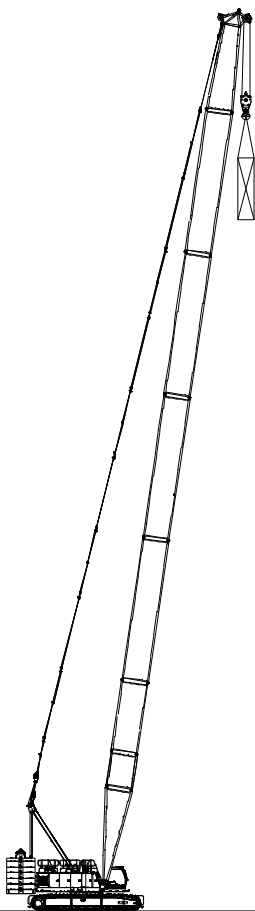

H Configuration

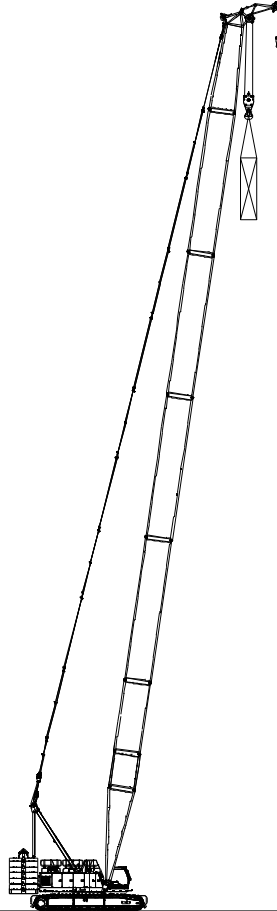

HCm Configuration
(double hooks, load on main hook)

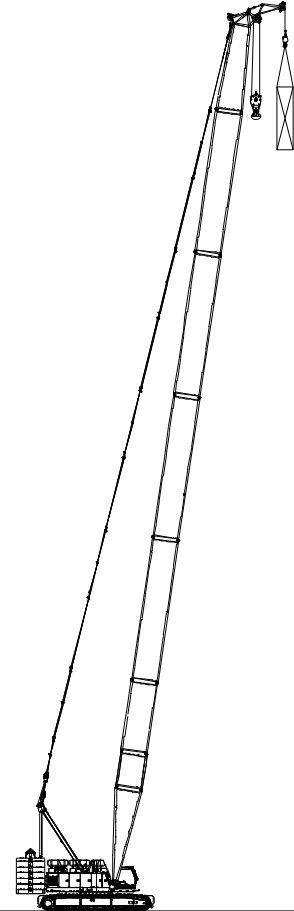

HCa Configuration
(double hooks, load on aux. hook)

Configuration	Boom Combination	Boom Length
H	Boom	16m~85m
HCm	Boom + Extension jib (double hooks, load on main hook)	
HCa	Boom + Extension jib (double hooks, load on aux. hook)	

Note: The schematics above are just reference for loading only.

Boom Combination

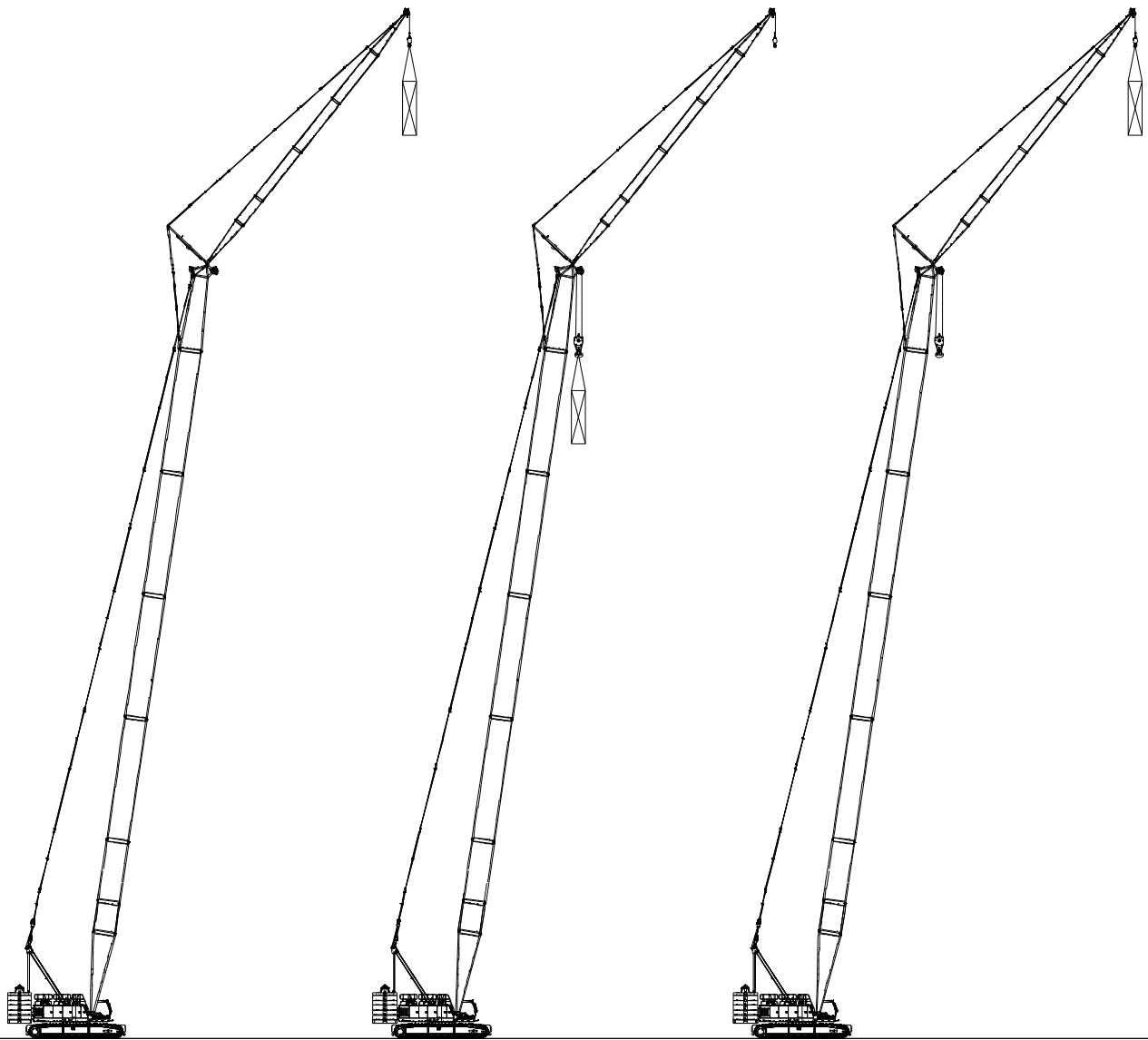

FJ Configuration
(single hook)

FJm Configuration
(double hooks, load on main hook)

FJa Configuration
(double hooks, load on aux. hook)

Configuration	Boom Combination	Boom Length
FJ	Boom + Fixed Jib (single hook)	(28m~70m)+(13m~31m)
FJm	Boom + Fixed Jib (double hooks, load on main hook)	
FJa	Boom + Fixed Jib (double hooks, load on aux. hook)	

Note: The schematics above are just reference for loading only.

Boom Combination

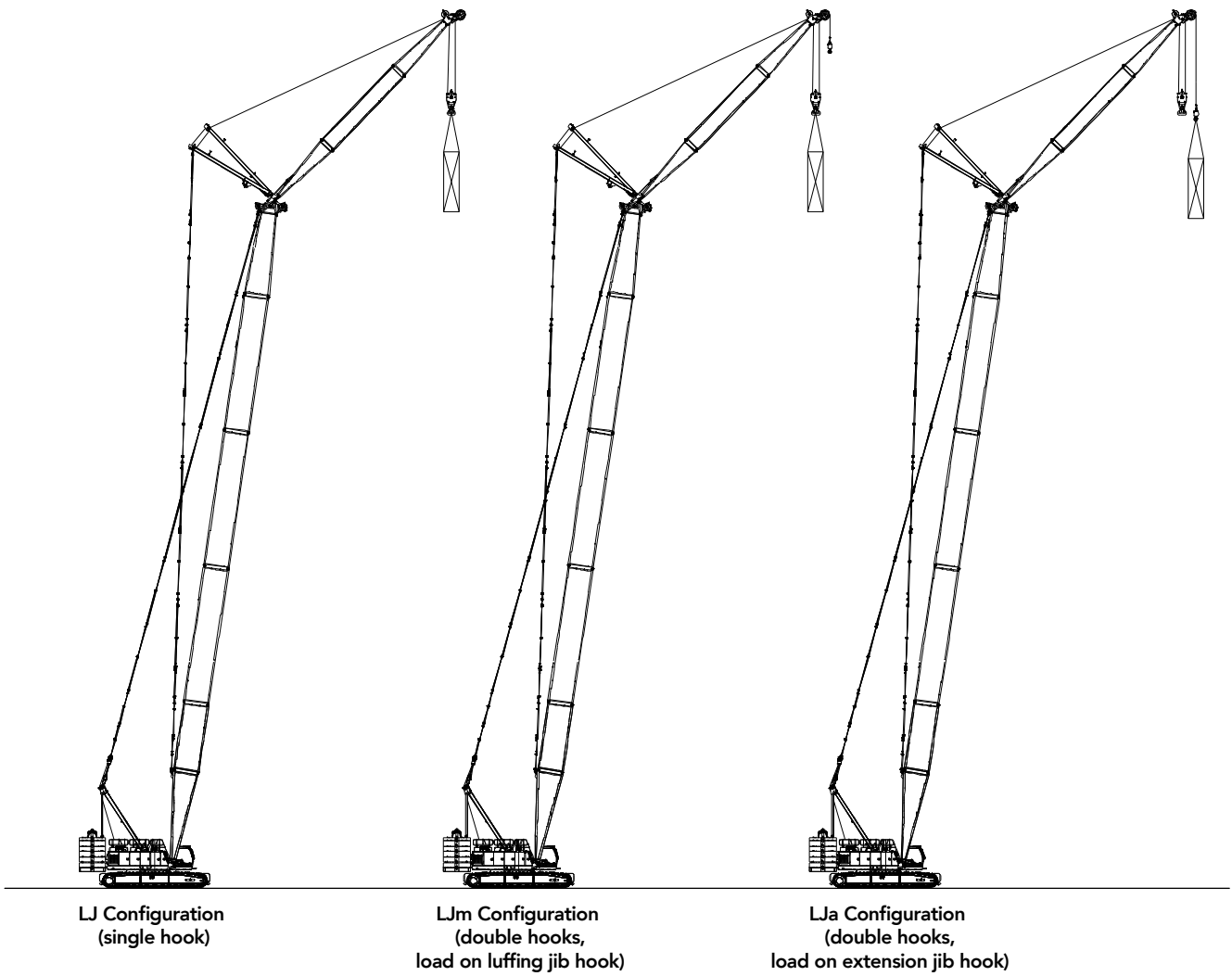

Configuration	Boom Combination	Boom Length
LJ	Boom + Luffing Jib (single hook)	(25m~55m)+(22m~58m)
LJm	Boom + Luffing Jib (double hooks, load on luffing jib hook)	
LJa	Boom + Luffing Jib (double hooks, load on extension jib hook)	

Note: The schematics above are just reference for loading only.

H Configuration

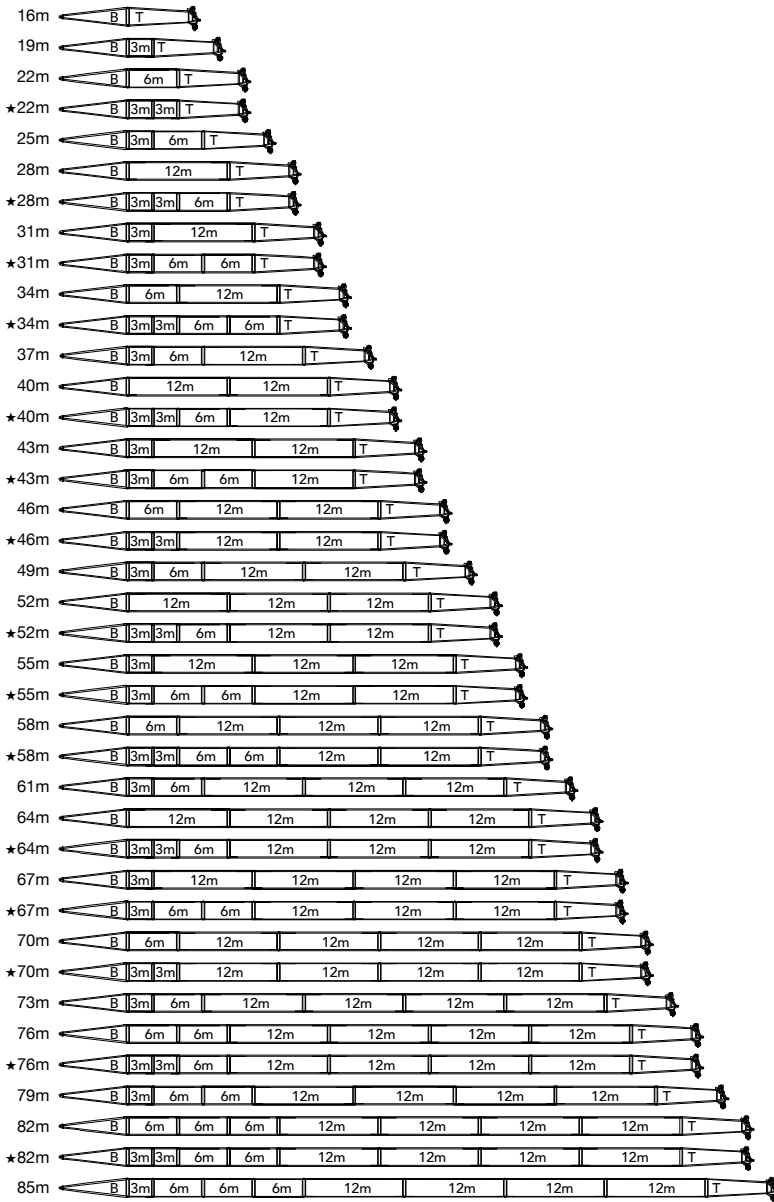

Note: ★ means recommended boom combination.

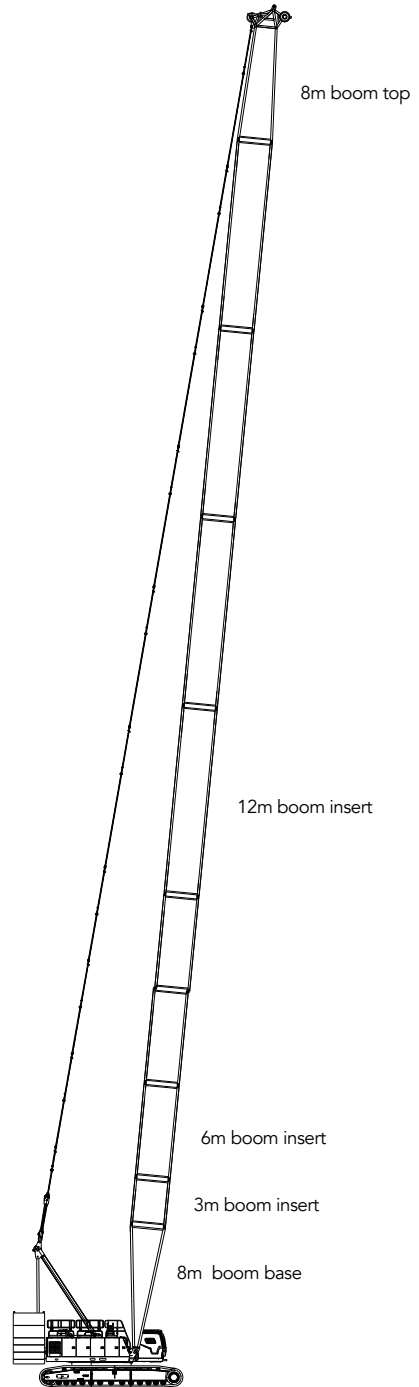
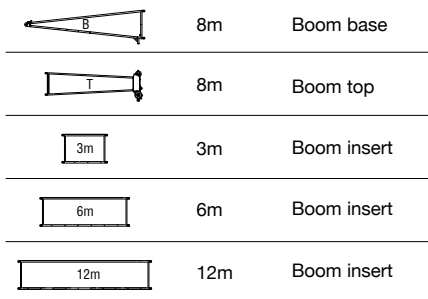

H Configuration
16m-85m

H Working Radius

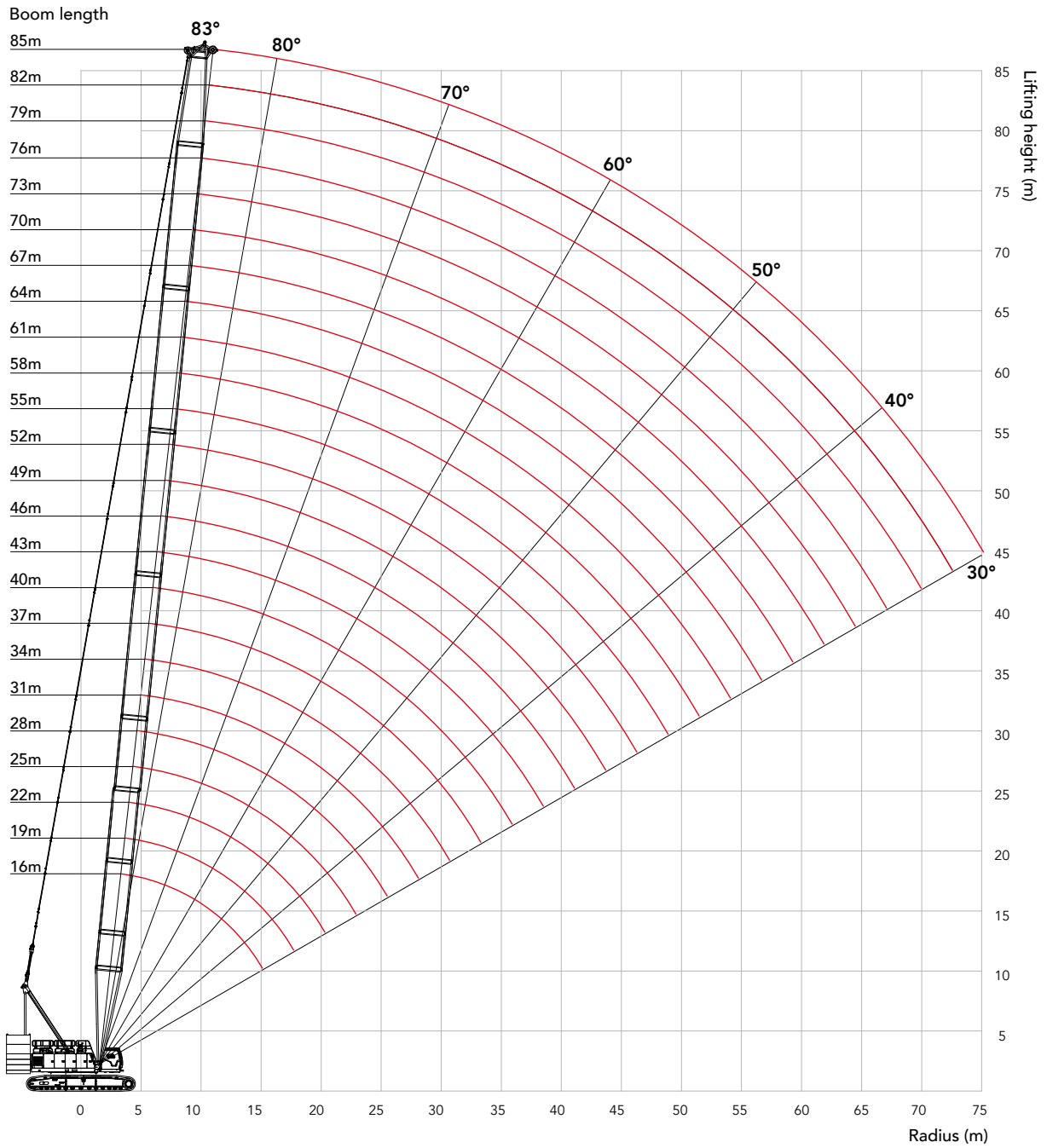

Unit: t

H Load Chart

Note:

- 1.The rated load in the load chart is calculated complying with EN 13000;
- 2.The working radius is the horizontal distance from the load center to the swing center;
- 3.The actual lifting capacity must subtract the weight of hooks and other riggings from the rated capacity in the load chart.
- 4.The load value is calculated when the object is hung freely,without considering the influence of wind on the load, ground conditions and slope, operation speed and the influence of any other negative factors over safe operation. Therefore, the operator bears the responsibility of making a judgement and decreasing the load and lowering speed.
- 5.All rated values are calculated when the machine is parking on firm and level ground with less than 1% gradient.
6. The rated values in the table shall deduct the covered weight of main hook.
7. The main hook must lift to the top and shall not attach load when using the auxiliary hook for lifting.
8. See Operation Manual for load charts of HcM configuration.

Load chart -H(Boom 16~85m, Rear counterweight 80t, Carbody counterweight 25t) 1/2

Boom length/ radius (m)	16	19	22	25	28	31	34	37	40	43	46	49	Boom length/ radius (m)
5	260.0	220.0											5
6	230.0	216.0	201.0	188.0									6
7	192.0	192.0	191.0	185.0	177.3	164.8							7
8	165.1	164.9	162.9	158.8	154.6	150.6	142.0	130.0	117.0	112.5			8
9	139.3	139.3	139.4	138.7	135.4	132.0	129.0	126.1	117.0	111.0	103.0	92.0	9
10	118.0	118.0	118.0	118.0	117.9	116.5	114.2	111.8	109.5	107.3	101.5	92.0	10
12	90.1	90.1	90.0	89.9	89.9	89.8	89.7	89.6	88.4	86.7	85.3	83.8	12
14	72.6	72.5	72.5	72.4	72.3	72.2	72.1	72.0	71.9	71.7	71.4	70.2	14
16		60.5	60.5	60.3	60.3	60.1	60.1	59.9	59.8	59.6	59.5	59.4	16
18		51.8	51.7	51.6	51.5	51.3	51.3	51.1	51.0	50.8	50.7	50.5	18
20			45.1	44.9	44.8	44.6	44.6	44.4	44.3	44.1	44.0	43.8	20
22				39.7	39.6	39.4	39.3	39.1	39.0	38.8	38.7	38.5	22
24					35.3	35.1	35.1	34.9	34.7	34.5	34.4	34.2	24
26					31.8	31.6	31.6	31.4	31.2	31.0	30.9	30.7	26
28						28.7	28.6	28.4	28.3	28.1	28.0	27.8	28
30							26.1	25.9	25.8	25.6	25.5	25.3	30
32								23.8	23.6	23.4	23.3	23.1	32
34								21.9	21.7	21.5	21.4	21.2	34
36									20.1	19.9	19.8	19.6	36
38										18.4	18.3	18.1	38
40											17.0	16.8	40
44												14.6	44
48													48
52													52
56													56
60													60
64													64
68													68
72													72

H Load Chart

Load chart -H(Boom 16~85m, Rear counterweight 80t, Carbody counterweight 25t) 2/2

Boom length/ radius (m)	52	55	58	61	64	67	70	73	76	79	82	85	Boom length/ radius (m)
5													5
6													6
7													7
8													8
9	87.9												9
10	87.2	79.0	72.5										10
12	82.3	78.7	71.8	65.3	59.3	53.9	49.3	45.2	41.5				12
14	69.1	67.9	66.9	64.9	58.9	53.7	49.1	44.7	40.9	37.1	33.7	30.6	14
16	59.2	58.3	57.5	56.6	55.7	53.1	48.5	43.8	39.6	35.9	32.6	29.5	16
18	50.4	50.2	50.1	49.4	48.6	47.8	47.1	42.5	38.4	34.8	31.4	28.4	18
20	43.6	43.5	43.3	43.1	43.0	42.3	41.7	41.0	37.2	33.6	30.3	27.4	20
22	38.3	38.1	38.0	37.8	37.7	37.5	37.1	36.5	35.9	32.5	29.3	26.3	22
24	34.1	33.9	33.7	33.5	33.4	33.2	33.0	32.8	32.2	31.4	28.2	25.4	24
26	30.5	30.3	30.2	30.0	29.8	29.6	29.5	29.3	29.0	28.6	27.2	24.4	26
28	27.6	27.4	27.3	27.0	26.9	26.7	26.5	26.3	26.1	25.9	25.4	23.5	28
30	25.1	24.9	24.7	24.5	24.3	24.1	24.0	23.8	23.5	23.4	23.1	22.6	30
32	22.9	22.7	22.6	22.4	22.2	22.0	21.8	21.6	21.4	21.2	21.0	20.6	32
34	21.0	20.8	20.7	20.5	20.3	20.1	19.9	19.7	19.5	19.3	19.1	18.8	34
36	19.4	19.2	19.0	18.8	18.6	18.4	18.3	18.0	17.8	17.6	17.4	17.2	36
38	17.9	17.7	17.6	17.3	17.2	16.9	16.8	16.6	16.3	16.1	16.0	15.7	38
40	16.6	16.4	16.3	16.0	15.8	15.6	15.5	15.3	15.0	14.8	14.6	14.4	40
44	14.4	14.2	14.0	13.8	13.6	13.4	13.2	13.0	12.8	12.6	12.4	12.2	44
48		12.3	12.2	12.0	11.8	11.5	11.4	11.2	10.9	10.7	10.5	10.3	48
52			10.6	10.4	10.2	10.0	9.9	9.6	9.4	9.2	9.0	8.8	52
56					8.9	8.7	8.5	8.3	8.1	7.9	7.7	7.4	56
60						7.6	7.4	7.2	6.9	6.7	6.5	6.2	60
64								6.2	5.9	5.8	5.5	5.2	64
68										4.9	4.6	4.2	68
72											3.8	3.4	72

Unit: t

HCa Load Chart

Note:

- 1.The rated load in the load chart is calculated complying with EN 13000;
- 2.The working radius is the horizontal distance from the load center to the swing center;
- 3.The actual lifting capacity must subtract the weight of hooks and other riggings from the rated capacity in the load chart.
- 4.The load value is calculated when the object is hung freely,without considering the influence of wind on the load, ground conditions and slope, operation speed and the influence of any other negative factors over safe operation. Therefore, the operator bears the responsibility of making a judgement and decreasing the load and lowering speed.
- 5.All rated values are calculated when the machine is parking on firm and level ground with less than 1% gradient.
6. The rated values in the table shall deduct the covered weight of main hook.
7. The main hook must lift to the top and shall not attach load when using the auxiliary hook for lifting.
8. See Operation Manual for load charts of HCa configuration.

Load chart -HCa(Boom 16~82m, Rear counterweight 80t, Carbody counterweight 25t) 1/2

Boom length/ radius (m)	16	19	22	25	28	31	34	37	40	43	46	49	Boom length/ radius (m)
6	24.0												6
7	24.0	24.0											7
8	24.0	24.0	24.0	24.0	24.0								8
9	24.0	24.0	24.0	24.0	24.0	24.0	24.0						9
10	24.0	24.0	24.0	24.0	24.0	24.0	24.0	24.0	24.0	24.0			10
12	22.8	23.7	24.0	24.0	24.0	24.0	24.0	24.0	24.0	24.0	24.0	24.0	12
14	21.8	22.6	23.2	23.8	24.0	24.0	24.0	24.0	24.0	24.0	24.0	24.0	14
16	21.3	21.8	22.3	22.9	23.4	23.9	24.0	24.0	24.0	24.0	24.0	24.0	16
18		21.3	21.6	22.1	22.7	23.0	23.5	23.8	24.0	24.0	24.0	24.0	18
20		21.3	21.2	21.8	22.0	22.5	22.9	23.3	23.6	23.9	24.0	24.0	20
22			21.2	21.3	21.7	22.0	22.4	22.6	23.0	23.4	23.5	23.8	22
24				21.3	21.3	21.6	21.9	22.3	22.6	22.8	23.1	23.3	24
26					21.2	21.4	21.6	21.9	22.1	22.5	22.6	23.0	26
28						21.2	21.3	21.4	21.8	22.1	22.3	22.6	28
30						21.3	21.2	21.3	21.5	21.7	21.9	22.2	30
32							21.4	21.1	21.3	21.4	21.7	21.7	32
34								20.6	20.4	20.2	20.1	19.9	34
36									18.8	18.6	18.5	18.3	36
38									17.5	17.3	17.2	16.9	38
40										16.0	15.9	15.7	40
44												13.6	44
48													48
52													52
56													56
60													60
64													64
68													68
72													72

HCa Load Chart

Load chart -HCa(Boom 16~82m, Rear counterweight 80t, Carbody counterweight 25t) 2/2

Boom length/ radius (m)	52	55	58	61	64	67	70	73	76	79	82	Boom length/ radius (m)
6												6
7												7
8												8
9												9
10												10
12	24.0	24.0										12
14	24.0	24.0	24.0	24.0	24.0	24.0	24.0					14
16	24.0	24.0	24.0	24.0	24.0	24.0	24.0	24.0	24.0	24.0	24.0	16
18	24.0	24.0	24.0	24.0	24.0	24.0	24.0	24.0	24.0	24.0	24.0	18
20	24.0	24.0	24.0	24.0	24.0	24.0	24.0	24.0	24.0	24.0	24.0	20
22	23.9	24.0	24.0	24.0	24.0	24.0	24.0	24.0	24.0	24.0	24.0	22
24	23.5	23.7	23.8	24.0	24.0	24.0	24.0	24.0	24.0	24.0	24.0	24
26	23.2	23.3	23.5	23.5	23.7	23.8	23.8	23.8	23.8	23.8	23.8	26
28	22.8	22.9	23.0	23.2	23.3	23.4	23.4	23.5	23.4	23.5	23.3	28
30	22.4	22.5	22.7	22.9	22.8	22.6	22.5	22.3	22.1	21.9	21.7	30
32	21.5	21.3	21.2	21.1	20.8	20.6	20.4	20.2	20.0	19.8	19.6	32
34	19.7	19.5	19.4	19.3	19.0	18.8	18.6	18.4	18.2	18.0	17.8	34
36	18.2	17.9	17.8	17.7	17.4	17.2	17.1	16.9	16.7	16.5	16.3	36
38	16.8	16.6	16.4	16.3	16.0	15.8	15.7	15.5	15.3	15.1	14.9	38
40	15.5	15.3	15.2	15.1	14.8	14.6	14.4	14.2	14.0	13.8	13.6	40
44	13.4	13.2	13.1	13.0	12.7	12.5	12.3	12.1	11.9	11.7	11.5	44
48	11.7	11.5	11.3	11.2	10.9	10.7	10.6	10.3	10.2	9.9	9.7	48
52			9.9	9.8	9.5	9.2	9.1	8.9	8.7	8.5	8.3	52
56				8.5	8.2	8.0	7.9	7.6	7.4	7.2	7.0	56
60						6.9	6.8	6.6	6.4	6.1	5.9	60
64							5.8	5.6	5.4	5.2	5.0	64
68									4.6	4.4	4.1	68
72										3.6	3.3	72

FJ Configuration

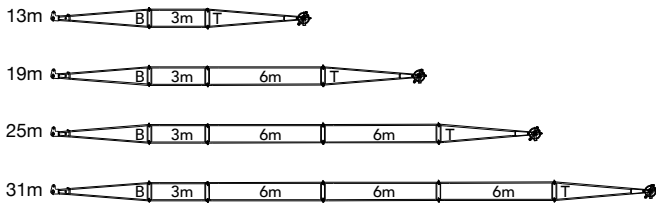

	5m	Fixed jib base
	5m	Fixed jib top
	6m	6m fixed jib insert
	3m	3m fixed jib insert

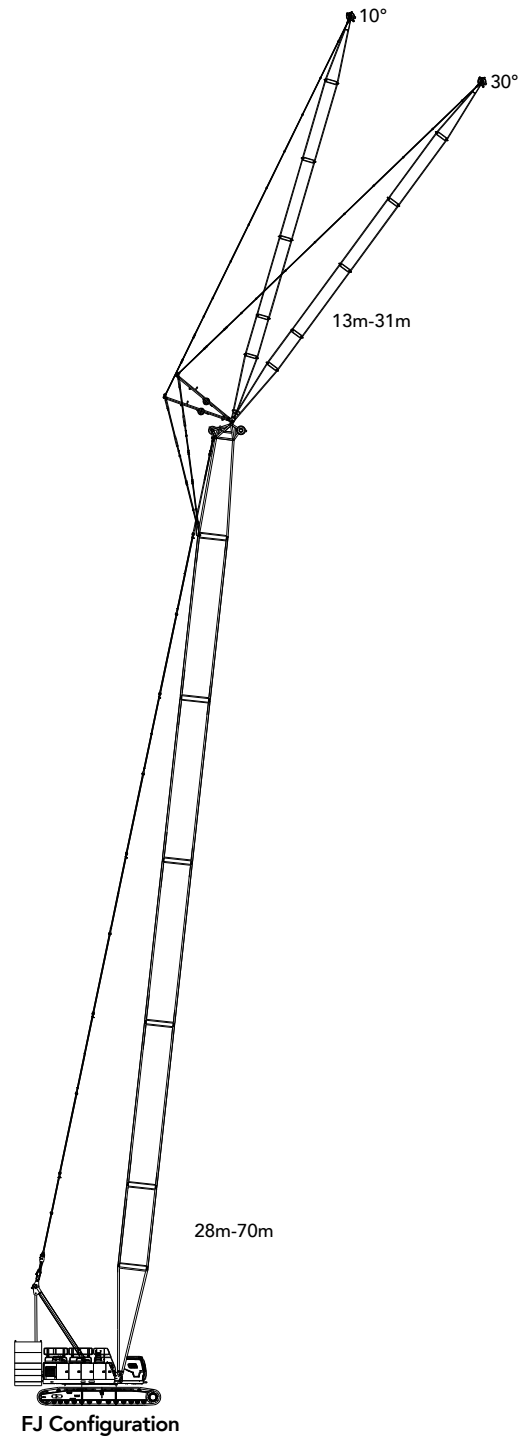

FJ Working Radius

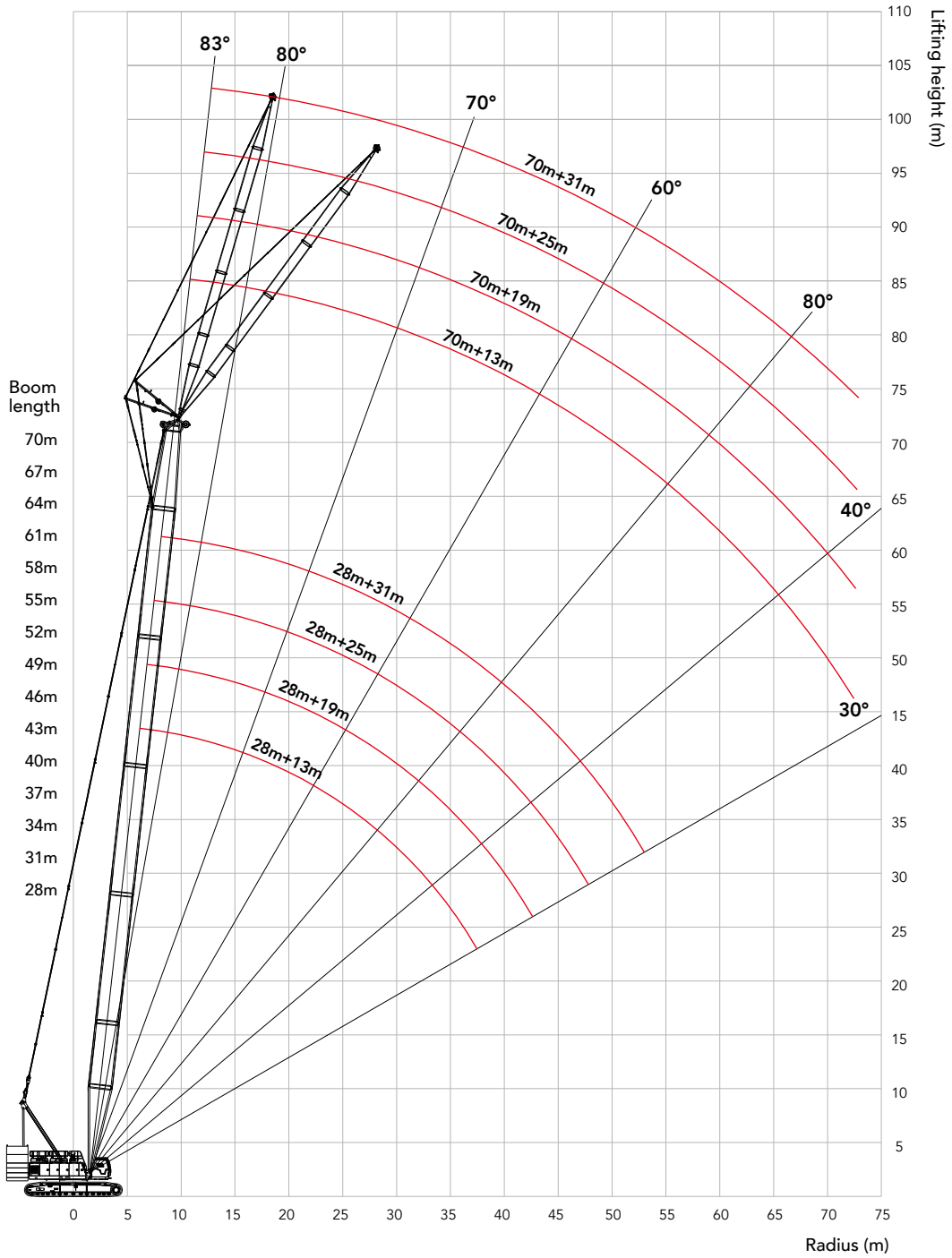

Unit: t

FJ Load Chart

Note:

- 1.The rated load in the load chart is calculated complying with EN 13000;
- 2.The working radius is the horizontal distance from the load center to the swing center;
- 3.The actual lifting capacity must subtract the weight of hooks and other riggings from the rated capacity in the load chart.
- 4.The load value is calculated when the object is hung freely,without considering the influence of wind on the load, ground conditions and slope, operation speed and the influence of any other negative factors over safe operation. Therefore, the operator bears the responsibility of making a judgement and decreasing the load and lowering speed.
- 5.All rated values are calculated when the machine is parking on firm and level ground with less than 1% gradient.
6. See Operation Manual for load charts of FJm and FJa configurations.

Load chart -FJ(Boom 28~70m, Rear counterweight 80t, Carbody counterweight 25t) 1/8

Boom to jib angle 10°, Jib 13m																
Radius (m)	28	31	34	37	40	43	46	49	52	55	58	61	64	67	70	Radius (m)
12	36.3	36.3														12
14	34.9	35.1	35.5	35.4	35.4	35.4										14
16	33.3	33.7	34.0	34.4	34.5	34.2	33.9	33.6	33.2	32.9						16
18	32.0	32.5	32.7	33.2	33.2	32.9	32.4	32.1	31.8	31.4	31.0	30.5	30.0	29.4		18
20	30.6	31.2	31.5	31.8	31.9	31.5	31.1	30.7	30.3	29.9	29.4	28.8	28.2	27.7	27.1	20
22	29.4	30.1	30.5	30.8	30.5	30.1	29.7	29.3	28.8	28.4	28.0	27.3	26.7	26.2	25.5	22
24	29.0	28.9	29.6	29.4	28.9	28.5	28.1	27.7	27.3	27.0	26.5	25.9	25.2	24.6	24.0	24
26	27.7	28.4	28.1	27.8	27.3	27.0	26.6	26.3	26.0	25.5	24.7	24.2	23.5	23.0	22.4	26
28	26.1	26.7	26.4	26.1	25.8	25.3	24.9	24.6	24.3	23.6	23.1	22.6	21.9	21.4	20.8	28
30	24.6	25.1	24.8	24.5	24.1	23.6	23.3	23.0	22.6	21.8	21.5	21.2	20.7	20.1	19.4	30
32	23.3	23.7	23.4	23.1	22.7	22.4	22.0	21.7	21.4	20.4	20.0	19.7	19.3	18.8	18.2	32
34	22.2	22.0	21.9	21.6	21.3	21.0	20.7	20.4	20.0	19.3	18.9	18.3	17.9	17.4	16.9	34
36	20.7	20.4	20.3	20.0	19.8	19.6	19.4	19.1	18.9	18.3	18.0	17.2	16.6	16.1	15.7	36
38	19.3	19.0	18.9	18.6	18.4	18.1	18.0	17.7	17.5	17.2	16.7	16.4	15.7	15.2	14.6	38
40		17.7	17.6	17.3	17.1	16.9	16.7	16.5	16.2	16.0	15.8	15.6	14.9	14.5	13.9	40
44				15.2	14.9	14.7	14.5	14.3	14.1	13.8	13.7	13.4	13.2	13.0	12.6	44
48					13.1	12.9	12.7	12.5	12.3	12.0	11.9	11.6	11.4	11.2	11.0	48
52							11.2	11.0	10.8	10.5	10.4	10.1	9.9	9.7	9.5	52
56								9.7	9.5	9.3	9.1	8.8	8.6	8.3	8.1	56
60										8.1	7.9	7.6	7.4	7.1	6.9	60
64											6.9	6.6	6.4	6.1	5.9	64
68													5.5	5.2	5.0	68
72														4.4	4.2	72

FJ Load Chart

Load chart -FJ(Boom 28~70m, Rear counterweight 80t, Carbody counterweight 25t) 2/8

Load chart -FJ(Boom 28~70m, Rear counterweight 80t, Carbody counterweight 25t) 2/8																
Boom to jib angle 10°, Jib 19m																
Radius (m)	28	31	34	37	40	43	46	49	52	55	58	61	64	67	70	Radius (m)
14	27.9	28.0														14
16	26.8	27.0	27.2	27.2	27.5	27.3										16
18	25.7	26.0	26.2	26.4	26.4	26.6	26.5	26.6	26.6	26.4						18
20	24.6	25.0	25.3	25.5	25.6	25.8	25.8	25.8	25.8	25.8	25.7	25.5	25.3	25.1		20
22	23.5	24.0	24.4	24.6	24.8	25.1	25.1	25.2	25.1	25.2	25.0	24.9	24.9	24.7	24.3	22
24	22.6	23.0	23.4	23.5	23.6	23.7	23.9	24.0	24.1	24.2	24.3	24.4	24.3	24.3	23.9	24
26	21.4	21.5	21.8	21.9	22.0	22.2	22.3	22.4	22.5	22.6	22.7	22.8	22.9	23.0	23.1	26
28	19.8	19.9	20.2	20.4	20.5	20.6	20.7	20.8	20.9	21.0	21.1	21.2	21.3	21.4	21.4	28
30	18.3	18.4	18.9	19.0	19.1	19.2	19.3	19.4	19.5	19.6	19.7	19.8	19.9	20.0	19.7	30
32	17.4	17.5	17.7	17.8	17.9	18.0	18.1	18.2	18.3	18.4	18.6	18.7	18.8	18.7	18.2	32
34	16.5	16.6	16.9	17.0	17.1	17.2	17.3	17.4	17.5	17.6	17.7	17.8	17.7	17.3	16.9	34
36	15.8	15.9	16.1	16.2	16.3	16.4	16.5	16.6	16.7	16.9	17.0	17.0	16.5	16.1	15.7	36
38	14.9	15.1	15.3	15.4	15.5	15.6	15.7	15.8	15.9	16.0	16.1	15.9	15.5	14.9	14.6	38
40	14.4	14.5	14.6	14.7	14.8	14.9	15.1	15.2	15.3	15.4	15.5	15.6	14.4	14.0	13.7	40
44	12.9	13.0	13.3	13.4	13.5	13.6	13.7	13.8	13.9	14.0	14.0	13.7	12.9	12.3	11.9	44
48			12.2	12.3	12.4	12.5	12.6	12.7	12.6	12.3	12.2	11.9	11.7	11.1	10.6	48
52				11.2	11.3	11.4	11.5	11.3	11.1	10.8	10.7	10.4	10.2	10.0	9.8	52
56						10.4	10.2	10.0	9.8	9.6	9.4	9.1	8.9	8.7	8.5	56
60								8.9	8.7	8.4	8.3	8.0	7.7	7.5	7.3	60
64									7.7	7.4	7.2	7.0	6.7	6.4	6.2	64
68											6.3	6.0	5.8	5.5	5.3	68
72												5.2	5.0	4.7	4.5	72
76														4.0	3.8	76
80															3.1	80

Unit: t

FJ Load Chart

Load chart -FJ(Boom 28~70m, Rear counterweight 80t, Carbody counterweight 25t) 3/8

Load chart -FJ(Boom 28~70m, Rear counterweight 80t, Carbody counterweight 25t) 3/8																
Boom to jib angle 10°, Jib 25m																
Radius (m)	28	31	34	37	40	43	46	49	52	55	58	61	64	67	70	Radius (m)
16	20.0	20.1														16
18	19.1	19.3	19.4	19.5	19.6	19.6										18
20	18.3	18.6	18.7	18.9	18.9	19.1	19.0	19.1	19.1	19.0						20
22	17.7	18.0	18.1	18.2	18.3	18.4	18.5	18.6	18.5	18.5	18.6	18.5	18.3	18.2		22
24	17.1	17.2	17.5	17.6	17.8	17.9	18.0	18.0	18.1	18.1	18.1	18.1	18.0	17.8	17.3	24
26	16.4	16.6	16.9	17.1	17.3	17.4	17.5	17.6	17.6	17.7	17.7	17.6	17.6	17.5	17.0	26
28	15.8	16.1	16.3	16.5	16.8	16.9	17.1	17.1	17.2	17.3	17.2	17.3	17.2	17.2	16.7	28
30	15.3	15.6	15.8	16.0	16.1	16.2	16.3	16.7	16.8	16.9	16.8	16.8	16.9	16.8	16.4	30
32	14.5	14.6	14.7	14.8	14.9	15.1	15.2	16.3	16.4	16.5	16.5	16.5	16.5	16.5	16.1	32
34	13.6	13.7	13.8	13.9	14.0	14.1	14.2	15.4	16.0	16.1	16.1	16.1	16.2	16.2	15.9	34
36	12.8	12.9	13.0	13.1	13.3	13.4	13.5	14.5	15.5	15.8	15.8	15.8	15.9	15.9	15.6	36
38	12.2	12.3	12.4	12.5	12.6	12.7	12.8	13.9	14.9	15.4	15.4	15.5	15.4	14.8	14.5	38
40	11.6	11.7	11.8	11.9	12.0	12.1	12.2	13.3	14.3	15.1	15.1	14.7	14.3	13.9	13.6	40
44	10.6	10.7	10.8	10.9	11.0	11.1	11.2	12.4	13.5	14.3	13.9	13.3	12.7	12.2	11.9	44
48	9.8	9.9	10.0	10.1	10.2	10.3	10.4	11.6	12.6	12.6	12.4	12.2	11.8	11.4	10.7	48
52		9.3	9.4	9.5	9.6	9.8	9.9	10.8	11.3	11.1	10.9	10.7	10.5	10.2	10.1	52
56				9.1	9.2	9.3	9.4	10.2	10.0	9.8	9.6	9.4	9.2	9.0	8.8	56
60					8.8	8.9	9.0	9.1	8.9	8.7	8.5	8.3	8.0	7.8	7.6	60
64							8.4	8.1	7.9	7.7	7.5	7.2	7.0	6.7	6.5	64
68								7.3	7.0	6.8	6.6	6.3	6.1	5.8	5.6	68
72										6.0	5.8	5.5	5.3	5.0	4.8	72
76												4.8	4.5	4.3	4.1	76
80													3.9	3.6	3.4	80
84															2.8	84

FJ Load Chart

Load chart -FJ(Boom 28~70m, Rear counterweight 80t, Carbody counterweight 25t) 4/8

Load chart -FJ(Boom 28~70m, Rear counterweight 80t, Carbody counterweight 25t) 4/8																
Boom to jib angle 10°, Jib 31m																
Radius (m)	28	31	34	37	40	43	46	49	52	55	58	61	64	67	70	Radius (m)
18	13.6	13.6														18
20	13.1	13.1	13.2	13.2	13.2	13.2										20
22	12.6	12.7	12.8	12.8	12.8	12.8	12.8	12.8	12.8	12.7						22
24	12.2	12.3	12.3	12.4	12.4	12.4	12.5	12.5	12.5	12.4	12.4	12.3	12.2	12.0		24
26	11.8	11.9	11.9	12.0	12.1	12.1	12.2	12.2	12.2	12.1	12.1	12.0	11.9	11.8	11.6	26
28	11.4	11.5	11.6	11.7	11.7	11.8	11.8	11.8	11.8	11.8	11.8	11.7	11.7	11.6	11.4	28
30	11.1	11.1	11.3	11.3	11.4	11.4	11.5	11.5	11.6	11.5	11.5	11.5	11.4	11.3	11.2	30
32	10.6	10.8	10.9	11.0	11.1	11.1	11.2	11.2	11.3	11.3	11.3	11.2	11.2	11.1	11.0	32
34	10.1	10.4	10.6	10.7	10.8	10.8	10.9	10.9	11.0	11.0	11.0	11.0	10.9	10.9	10.8	34
36	9.5	9.9	10.3	10.4	10.5	10.5	10.6	10.7	10.7	10.7	10.8	10.7	10.7	10.6	10.6	36
38	9.0	9.3	9.8	10.1	10.2	10.3	10.4	10.4	10.5	10.5	10.5	10.5	10.5	10.4	10.4	38
40	8.6	8.9	9.2	9.6	10.0	10.0	10.1	10.2	10.2	10.3	10.3	10.3	10.3	10.2	10.2	40
44	7.7	8.1	8.5	8.8	9.1	9.4	9.7	9.7	9.8	9.8	9.9	9.9	9.9	9.8	9.8	44
48	7.1	7.5	7.7	8.1	8.4	8.7	9.0	9.3	9.4	9.4	9.5	9.5	9.5	9.5	9.4	48
52	6.6	6.9	7.2	7.5	7.7	8.1	8.4	8.7	9.0	9.0	9.1	9.1	9.1	9.1	9.1	52
56		6.5	6.7	6.9	7.2	7.5	7.7	8.1	8.4	8.6	8.8	8.8	8.8	8.8	8.8	56
60			6.3	6.5	6.8	7.0	7.2	7.4	7.6	7.8	8.5	8.5	8.2	8.0	7.8	60
64					6.4	6.6	6.8	7.0	7.2	7.4	7.7	7.4	7.2	7.0	6.8	64
68						6.3	6.5	6.7	6.9	7.0	6.8	6.5	6.3	6.0	5.8	68
72								6.1	6.4	6.2	6.0	5.7	5.5	5.2	5.0	72
76									5.7	5.4	5.2	5.0	4.7	4.5	4.3	76
80											4.6	4.3	4.1	3.8	3.6	80
84												3.7	3.5	3.2	3.0	84
88														2.7	2.5	88

Unit: t

FJ Load Chart

Load chart -FJ(Boom 28~70m, Rear counterweight 80t, Carbody counterweight 25t) 5/8

Boom to jib angle 30°, Jib 13m																
Radius (m)	28	31	34	37	40	43	46	49	52	55	58	61	64	67	70	Radius (m)
16	17.3	17.5														16
18	16.6	16.8	17.0	17.1	17.2	17.4										18
20	16.0	16.2	16.4	16.6	16.7	16.8	17.0	17.1	17.1	17.1						20
22	15.5	15.7	15.9	16.1	16.3	16.4	16.5	16.6	16.8	16.8	16.8	16.8	16.8	17.0		22
24	15.0	15.3	15.5	15.7	15.9	16.0	16.1	16.2	16.3	16.4	16.6	16.6	16.6	16.6	16.6	24
26	14.6	14.9	15.0	15.2	15.4	15.6	15.7	15.8	15.9	16.1	16.2	16.2	16.2	16.3	16.3	26
28	14.2	14.5	14.7	14.9	15.1	15.3	15.4	15.6	15.7	15.7	15.8	15.9	15.9	16.0	16.1	28
30	13.9	14.2	14.4	14.5	14.7	15.0	15.1	15.3	15.3	15.4	15.5	15.7	15.7	15.8	15.8	30
32	13.7	13.9	14.1	14.4	14.7	14.9	15.1	15.3	15.5	15.2	15.3	15.4	15.5	15.5	15.6	32
34	13.5	13.8	14.2	14.4	14.6	14.8	15.0	15.3	15.4	15.6	15.0	15.1	15.2	15.3	15.3	34
36	13.2	13.5	13.8	14.2	14.4	14.6	14.8	15.0	15.2	15.4	15.0	14.9	15.0	15.0	15.1	36
38	13.1	13.3	13.6	13.8	14.1	14.3	14.5	14.7	14.9	15.1	15.3	14.6	14.7	14.8	14.9	38
40		13.1	13.3	13.6	13.8	14.0	14.2	14.4	14.6	14.8	15.1	15.3	14.5	14.3	14.0	40
44			12.7	12.9	13.1	13.4	13.6	13.8	14.0	14.1	14.1	13.9	13.7	13.5	12.6	44
48					12.6	12.8	12.9	12.7	12.6	12.3	12.2	12.0	11.8	11.6	11.5	48
52						11.5	11.4	11.2	11.0	10.8	10.6	10.4	10.3	10.0	9.9	52
56								9.8	9.6	9.4	9.3	9.1	8.9	8.6	8.5	56
60									8.5	8.2	8.1	7.9	7.7	7.4	7.2	60
64											7.0	6.8	6.6	6.3	6.2	64
68												5.8	5.6	5.4	5.2	68
72														4.5	4.3	72

FJ Load Chart

Load chart -FJ(Boom 28~70m, Rear counterweight 80t, Carbody counterweight 25t) 6/8

Load chart -FJ(Boom 28~70m, Rear counterweight 80t, Carbody counterweight 25t) 6/8																
Boom to jib angle 30°, Jib 19m																
Radius (m)	28	31	34	37	40	43	46	49	52	55	58	61	64	67	70	Radius (m)
20	11.6	11.8														20
22	11.2	11.3	11.5	11.5	11.7	11.7										22
24	10.8	10.9	11.1	11.1	11.3	11.3	11.5	11.5	11.6	11.6						24
26	10.4	10.5	10.7	10.8	11.0	11.0	11.2	11.2	11.3	11.3	11.4	11.5	11.5	11.6		26
28	10.0	10.3	10.4	10.5	10.7	10.7	10.9	10.9	11.0	11.1	11.2	11.2	11.2	11.3	11.3	28
30	9.7	9.9	10.1	10.2	10.4	10.5	10.6	10.7	10.8	10.8	10.9	10.9	11.0	11.0	11.1	30
32	9.4	9.7	9.8	9.9	10.1	10.2	10.3	10.4	10.5	10.6	10.6	10.7	10.9	10.9	10.9	32
34	9.2	9.4	9.6	9.7	9.8	10.0	10.1	10.2	10.3	10.4	10.4	10.6	10.6	10.7	10.7	34
36	9.0	9.2	9.4	9.5	9.6	9.8	9.9	10.0	10.1	10.1	10.3	10.4	10.4	10.4	10.5	36
38	8.8	9.0	9.2	9.3	9.4	9.6	9.7	9.8	9.9	10.0	10.1	10.1	10.2	10.3	10.4	38
40	8.7	8.9	8.9	9.1	9.2	9.3	9.5	9.6	9.7	9.8	9.9	10.0	10.0	10.1	10.2	40
44	8.6	8.6	8.7	8.8	9.0	9.1	9.1	9.2	9.4	9.4	9.6	9.6	9.8	9.8	9.8	44
48		8.6	8.6	8.7	8.7	8.8	8.9	9.0	9.1	9.2	9.3	9.4	9.5	9.5	9.6	48
52				8.8	8.7	8.7	8.7	8.8	9.0	9.1	9.2	9.4	9.5	9.6	9.6	52
56						9.0	9.0	9.1	9.2	9.3	9.4	9.5	9.4	9.2	9.0	56
60							9.0	9.1	8.9	8.7	8.6	8.4	8.2	7.9	7.8	60
64									7.8	7.6	7.5	7.3	7.1	6.8	6.7	64
68										6.6	6.5	6.3	6.1	5.9	5.7	68
72												5.4	5.2	5.0	4.8	72
76													4.4	4.2	4.0	76
80															3.3	80

Unit: t

FJ Load Chart

Load chart -FJ(Boom 28~70m, Rear counterweight 80t, Carbody counterweight 25t) 7/8																
Boom to jib angle 30°, Jib 25m																
Radius (m)	28	31	34	37	40	43	46	49	52	55	58	61	64	67	70	Radius (m)
24	8.2	8.2														24
26	7.8	7.9	8.0	8.1	8.2	8.3										26
28	7.5	7.6	7.7	7.8	7.9	8.0	8.0	8.2	8.2	8.2						28
30	7.3	7.4	7.6	7.6	7.7	7.8	7.8	7.9	8.0	8.0	8.1	8.1	8.1	8.1		30
32	7.1	7.2	7.3	7.4	7.5	7.6	7.7	7.7	7.8	7.8	7.9	7.9	7.9	8.0	8.0	32
34	6.8	7.0	7.1	7.2	7.3	7.4	7.5	7.5	7.6	7.6	7.7	7.7	7.8	7.8	7.8	34
36	6.6	6.8	6.9	7.0	7.1	7.2	7.3	7.3	7.4	7.5	7.5	7.6	7.6	7.6	7.7	36
38	6.4	6.6	6.7	6.8	6.9	7.0	7.1	7.2	7.2	7.3	7.4	7.4	7.5	7.5	7.6	38
40	6.3	6.4	6.5	6.6	6.7	6.8	6.9	7.0	7.1	7.1	7.2	7.3	7.3	7.3	7.4	40
44	6.0	6.1	6.2	6.3	6.5	6.6	6.6	6.7	6.8	6.8	6.9	7.0	7.0	7.1	7.2	44
48	5.8	5.9	6.0	6.1	6.2	6.3	6.4	6.5	6.6	6.6	6.7	6.7	6.8	6.8	6.9	48
52		5.8	5.9	5.9	6.0	6.1	6.1	6.2	6.3	6.4	6.5	6.5	6.6	6.7	6.7	52
56			5.8	5.8	5.9	5.9	6.0	6.1	6.1	6.2	6.3	6.3	6.4	6.4	6.5	56
60					5.8	5.8	5.9	5.9	6.0	6.0	6.1	6.1	6.2	6.3	6.3	60
64						5.8	5.8	5.8	5.9	5.9	5.9	6.0	6.1	6.1	6.2	64
68								5.8	5.8	5.8	5.9	5.9	5.9	6.0	6.0	68
72									6.2	6.0	6.0	5.8	5.6	5.4	5.2	72
76											5.2	5.0	4.8	4.6	4.4	76
80												4.2	4.1	3.9	3.7	80
84														3.2	3.0	84

FJ Load Chart

Load chart -FJ(Boom 28~70m, Rear counterweight 80t, Carbody counterweight 25t) 8/8

Load chart -FJ(Boom 28~70m, Rear counterweight 80t, Carbody counterweight 25t) 8/8																
Boom to jib angle 30°, Jib 31m																
Radius (m)	28	31	34	37	40	43	46	49	52	55	58	61	64	67	70	Radius (m)
28	6.0	6.0														28
30	5.7	5.8	5.8	5.9	5.9	6.0										30
32	5.5	5.6	5.6	5.7	5.8	5.8	5.8	5.9	5.9	5.9						32
34	5.3	5.3	5.4	5.5	5.5	5.6	5.7	5.7	5.8	5.8	5.8	5.9	5.9	5.9		34
36	5.1	5.2	5.3	5.3	5.4	5.5	5.5	5.6	5.6	5.7	5.7	5.7	5.8	5.8	5.8	36
38	4.9	5.0	5.1	5.2	5.3	5.3	5.4	5.4	5.5	5.5	5.6	5.6	5.6	5.6	5.7	38
40	4.7	4.9	4.9	5.0	5.1	5.2	5.2	5.3	5.4	5.4	5.4	5.5	5.5	5.5	5.6	40
44	4.5	4.6	4.7	4.7	4.8	4.9	5.0	5.0	5.1	5.1	5.2	5.2	5.2	5.3	5.3	44
48	4.3	4.3	4.4	4.5	4.6	4.7	4.7	4.8	4.8	4.9	5.0	5.0	5.1	5.1	5.1	48
52	4.1	4.2	4.2	4.3	4.4	4.5	4.5	4.6	4.7	4.7	4.8	4.8	4.9	4.9	5.0	52
56	4.0	4.0	4.1	4.2	4.2	4.3	4.3	4.4	4.5	4.5	4.6	4.6	4.7	4.7	4.8	56
60		4.0	4.0	4.0	4.1	4.1	4.2	4.3	4.3	4.4	4.4	4.5	4.5	4.6	4.6	60
64				4.0	4.0	4.0	4.1	4.1	4.2	4.3	4.3	4.4	4.4	4.4	4.5	64
68						4.0	4.0	4.1	4.1	4.1	4.2	4.2	4.3	4.3	4.4	68
72							4.0	4.0	4.0	4.1	4.1	4.1	4.2	4.2	4.3	72
76									4.0	4.0	4.0	4.1	4.1	4.1	4.1	76
80										4.0	4.0	4.0	4.0	4.1	4.1	80
84												3.9	3.8	3.5	3.4	84
88													3.1	2.9	2.8	88

LJ Configuration

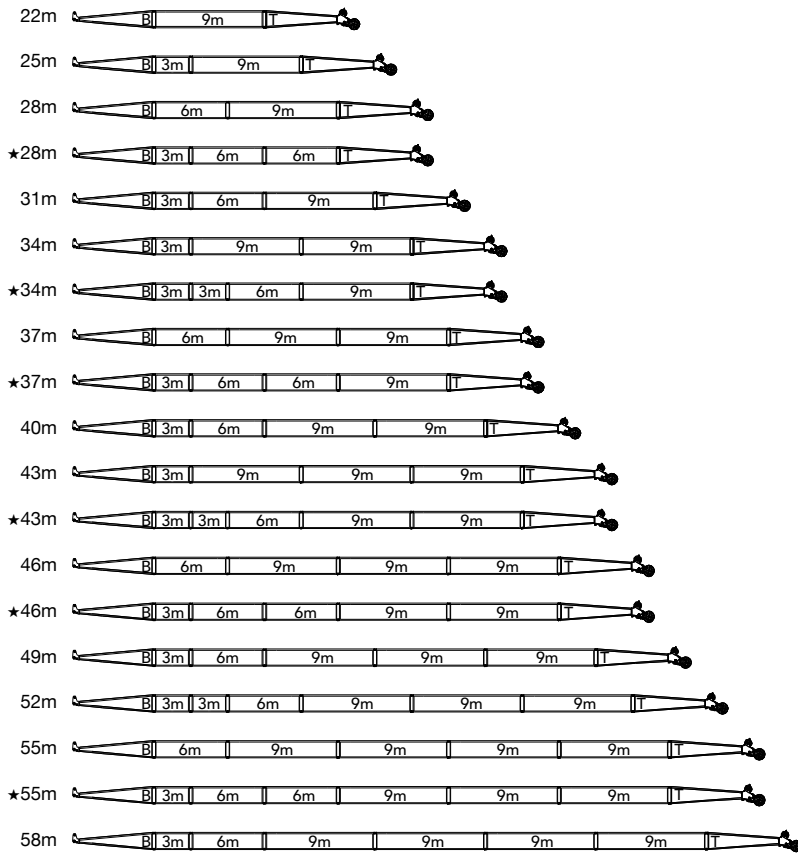

Note: ★ means recommended boom combination.

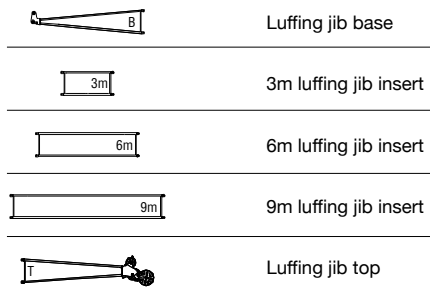

LJ Working Radius

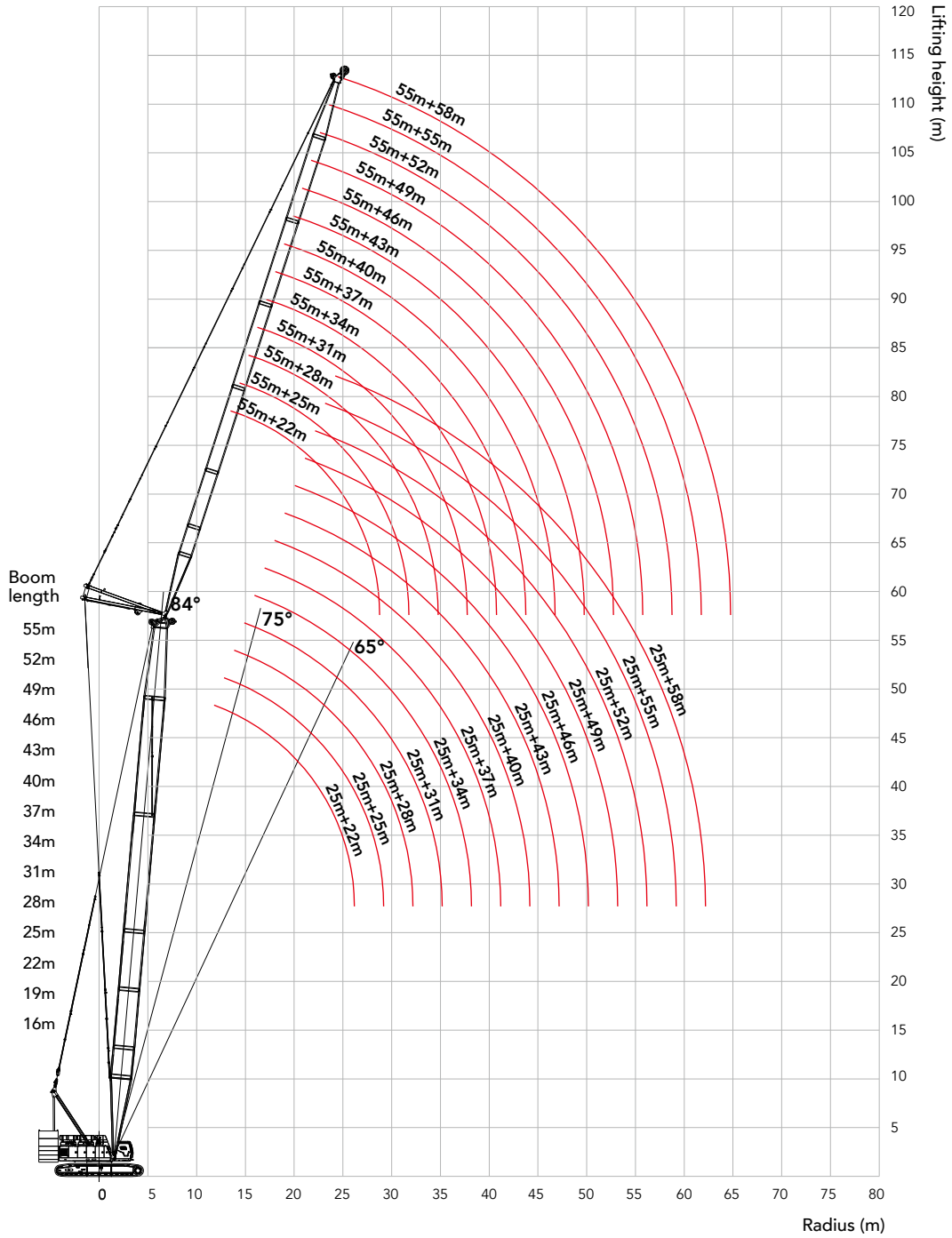

Unit: t

LJ Load Chart

Note:

- 1.The rated load in the load chart is calculated complying with EN 13000;
- 2.The working radius is the horizontal distance from the load center to the swing center;
- 3.The actual lifting capacity must subtract the weight of hooks and other riggings from the rated capacity in the load chart.
- 4.The load value is calculated when the object is hung freely,without considering the influence of wind on the load, ground conditions and slope, operation speed and the influence of any other negative factors over safe operation. Therefore, the operator bears the responsibility of making a judgement and decreasing the load and lowering speed.
- 5.All rated values are calculated when the machine is parking on firm and level ground with less than 1% gradient.
6. See Operation Manual for load charts of LJm and LJn configurations.

Load chart -LJ(Jib 22~58m, Boom angle 84°, Rear counterweight 80t, Carbody counterweight 25t) 1/11

Radius (m)	Boom 25m													Radius (m)
	22	25	28	31	34	37	40	43	46	49	52	55	58	
12	66.8	61.5												12
14	52.7	53.0	54.3	49.9										14
16	43.1	43.4	44.5	44.4	44.2	38.6	33.6							16
18	36.4	36.6	37.6	37.4	37.3	37.2	33.3	29.1	25.5					18
20	31.4	31.6	32.5	32.3	32.2	32.1	31.9	28.7	25.1	22.1	19.5			20
22	27.6	27.7	28.5	28.4	28.3	28.1	27.9	27.8	24.8	21.7	19.1	16.8	14.8	22
24	24.5	24.7	25.4	25.2	25.1	25.0	24.8	24.7	24.4	21.3	18.7	16.5	14.5	24
26		22.2	22.8	22.7	22.6	22.4	22.3	22.1	22.0	21.0	18.4	16.1	14.1	26
28		18.5	20.7	20.6	20.5	20.3	20.2	20.0	19.9	19.7	18.0	15.7	13.8	28
30			18.1	18.8	18.7	18.5	18.4	18.2	18.1	18.0	17.6	15.4	13.4	30
32				17.2	17.1	17.0	16.8	16.7	16.6	16.4	16.3	15.0	13.1	32
34				13.4	15.8	15.7	15.5	15.4	15.3	15.1	15.0	14.7	12.8	34
36					13.2	14.5	14.4	14.3	14.1	14.0	13.8	13.7	12.5	36
38						12.8	13.4	13.3	13.1	13.0	12.8	12.7	12.1	38
40						10.1	12.3	12.4	12.2	12.1	11.9	11.8	11.6	40
44								9.7	10.7	10.5	10.4	10.3	10.1	44
48									7.6	8.9	9.2	9.0	8.7	48
52										5.8	7.1	7.8	7.4	52
56												5.5	6.1	56
60													4.2	60

Load chart -LJ(Jib 22~58m, Boom angle 84°, Rear counterweight 80t, Carbody counterweight 25t) 2/11

Radius (m)	Boom 28m													Radius (m)
	22	25	28	31	34	37	40	43	46	49	52	55	58	
12	66.3													12
14	54.6	54.9	55.3	49.8										14
16	44.4	44.6	46.0	46.0	43.1	37.4								16
18	37.3	37.5	38.6	38.6	38.6	37.2	32.4	28.4	24.9					18
20	32.1	32.3	33.2	33.2	33.2	33.1	32.1	28.1	24.6	21.7	19.1			20
22	28.1	28.3	29.1	29.0	29.0	28.9	28.8	27.7	24.3	21.3	18.8	16.6	14.6	22
24	25.0	25.1	25.8	25.7	25.7	25.6	25.5	25.4	23.9	21.0	18.4	16.2	14.3	24
26	20.6	22.5	23.2	23.1	23.1	23.0	22.8	22.7	22.6	20.6	18.1	15.9	14.0	26
28		20.4	21.0	20.9	20.9	20.8	20.7	20.5	20.4	20.2	17.7	15.5	13.6	28
30			19.1	19.1	19.0	18.9	18.8	18.7	18.5	18.4	17.4	15.2	13.3	30
32			14.7	17.5	17.4	17.3	17.2	17.1	17.0	16.8	16.7	14.9	13.0	32
34				14.8	16.1	16.0	15.9	15.8	15.6	15.5	15.3	14.5	12.7	34
36					14.5	14.8	14.7	14.6	14.4	14.3	14.2	14.0	12.4	36
38						13.7	13.6	13.5	13.4	13.2	13.1	13.0	12.1	38
40						11.1	12.7	12.6	12.5	12.3	12.2	12.1	11.8	40
44								10.7	10.9	10.8	10.6	10.5	10.3	44
48									8.4	9.5	9.4	9.2	9.1	48
52										6.5	7.9	8.2	7.7	52
56												6.2	6.4	56
60													4.8	60

LJ Load Chart**Load chart -LJ(Jib 22~58m, Boom angle 84°, Rear counterweight 80t, Carbody counterweight 25t) 3/11**

Load chart -LJ(Jib 22~58m, Boom angle 84°, Rear counterweight 80t, Carbody counterweight 25t) 3/11														
Boom 31m														
Radius (m)	22	25	28	31	34	37	40	43	46	49	52	55	58	Radius (m)
12	64.0													12
14	56.6	55.4	54.0											14
16	45.7	46.0	47.4	47.4	41.4	36.1								16
18	38.3	38.5	39.6	39.6	39.6	35.9	31.4	27.6						18
20	32.8	33.0	34.0	33.9	33.9	33.9	31.2	27.3	24.0	21.2	18.8			20
22	28.7	28.8	29.7	29.6	29.6	29.5	29.4	27.0	23.7	20.9	18.4	16.3	14.4	22
24	25.4	25.5	26.3	26.2	26.2	26.1	26.0	25.9	23.4	20.6	18.1	16.0	14.1	24
26	22.8	22.9	23.6	23.5	23.4	23.4	23.2	23.2	23.1	20.2	17.8	15.6	13.7	26
28		20.7	21.3	21.2	21.2	21.1	21.0	20.9	20.8	19.9	17.5	15.3	13.4	28
30			19.4	19.3	19.3	19.2	19.1	19.0	18.9	18.7	17.1	15.0	13.2	30
32			16.3	17.7	17.7	17.6	17.4	17.4	17.3	17.1	16.8	14.7	12.9	32
34				16.1	16.3	16.2	16.1	16.0	15.9	15.7	15.6	14.4	12.5	34
36					15.1	15.0	14.8	14.7	14.6	14.5	14.4	14.1	12.2	36
38					12.1	13.9	13.8	13.7	13.6	13.4	13.3	13.2	12.0	38
40						12.2	12.8	12.7	12.6	12.5	12.4	12.3	11.7	40
44								11.1	11.0	10.9	10.8	10.7	10.5	44
48									9.1	9.6	9.5	9.4	9.2	48
52										7.1	8.4	8.3	7.8	52
56												6.8	6.6	56
60													5.3	60

Load chart -LJ(Jib 22~58m, Boom angle 84°, Rear counterweight 80t, Carbody counterweight 25t) 4/11

Load chart -LJ(Jib 22~58m, Boom angle 84°, Rear counterweight 80t, Carbody counterweight 25t) 4/11														
Boom 34m														
Radius (m)	22	25	28	31	34	37	40	43	46	49	52	55	58	Radius (m)
12	61.3													12
14	54.6	53.4	51.8											14
16	47.1	47.4	47.0	45.3	39.7	34.8								16
18	39.3	39.5	40.7	40.6	39.5	34.6	30.4	26.8						18
20	33.6	33.8	34.7	34.7	34.7	34.4	30.1	26.5	23.4	20.7				20
22	29.3	29.4	30.3	30.2	30.2	30.1	29.9	26.2	23.1	20.4	18.0	15.9	14.1	22
24	25.9	26.0	26.8	26.7	26.7	26.6	26.5	25.9	22.8	20.1	17.7	15.6	13.8	24
26	23.2	23.3	23.9	23.9	23.8	23.8	23.6	23.6	22.5	19.8	17.4	15.4	13.5	26
28		21.0	21.6	21.5	21.5	21.4	21.3	21.2	21.1	19.5	17.1	15.1	13.3	28
30			19.7	19.6	19.5	19.5	19.3	19.3	19.2	19.0	16.8	14.8	13.0	30
32			17.5	17.9	17.9	17.8	17.7	17.6	17.5	17.4	16.5	14.5	12.7	32
34				16.5	16.5	16.4	16.3	16.2	16.1	15.9	15.8	14.2	12.4	34
36					15.2	15.1	15.0	14.9	14.8	14.7	14.6	13.9	12.1	36
38					13.1	14.1	13.9	13.8	13.7	13.6	13.5	13.4	11.8	38
40						13.0	13.0	12.9	12.8	12.6	12.5	12.4	11.6	40
44							10.0	11.3	11.1	11.0	10.9	10.8	10.6	44
48									9.8	9.7	9.6	9.4	9.3	48
52										7.7	8.5	8.4	8.0	52
56												7.1	6.7	56
60													5.6	60

Unit: t

LJ Load Chart

Load chart -LJ(Jib 22~58m, Boom angle 84°, Rear counterweight 80t, Carbody counterweight 25t) 5/11

Radius (m)	Boom 37m												Radius (m)	
	22	25	28	31	34	37	40	43	46	49	52	55		58
14	53.1	51.8	49.1											14
16	47.6	46.7	45.9	42.9	37.8									16
18	40.3	40.6	41.7	40.8	37.6	33.2	29.2	25.9						18
20	34.4	34.5	35.6	35.5	35.5	32.9	29.0	25.7	22.7	20.1				20
22	29.9	30.0	30.9	30.8	30.8	30.8	28.8	25.4	22.5	19.8	17.6	15.6		22
24	26.4	26.5	27.3	27.2	27.2	27.1	27.0	25.2	22.2	19.6	17.3	15.3	13.5	24
26	23.6	23.7	24.3	24.3	24.2	24.2	24.0	24.0	21.9	19.3	17.0	15.0	13.3	26
28		21.4	22.0	21.9	21.8	21.8	21.6	21.6	21.5	19.0	16.8	14.8	13.0	28
30		18.8	20.0	19.9	19.8	19.7	19.6	19.5	19.4	18.7	16.5	14.5	12.7	30
32			18.3	18.2	18.1	18.1	17.9	17.8	17.7	17.6	16.2	14.2	12.5	32
34				16.7	16.7	16.6	16.5	16.4	16.3	16.1	15.9	13.9	12.2	34
36					15.4	15.3	15.2	15.1	15.0	14.9	14.8	13.7	11.9	36
38					14.0	14.2	14.1	14.0	13.9	13.8	13.6	13.4	11.7	38
40						13.2	13.1	13.0	12.9	12.8	12.7	12.5	11.4	40
44							10.8	11.4	11.3	11.1	11.0	10.9	10.7	44
48									9.9	9.8	9.7	9.5	9.4	48
52										8.2	8.6	8.4	8.2	52
56											6.4	7.4	6.9	56
60													5.7	60

Load chart -LJ(Jib 22~58m, Boom angle 84°, Rear counterweight 80t, Carbody counterweight 25t) 6/11

Radius (m)	Boom 40m												Radius (m)	
	22	25	28	31	34	37	40	43	46	49	52	55		58
14	51.1	49.8												14
16	46.2	45.3	44.1	40.6	36.0									16
18	41.5	41.0	40.3	39.4	35.8	31.7	28.1							18
20	35.2	35.4	36.4	36.1	35.4	31.4	27.9	24.7	22.0	19.5				20
22	30.5	30.7	31.6	31.5	31.5	31.1	27.7	24.5	21.7	19.3	17.1	15.2		22
24	26.9	27.0	27.8	27.7	27.7	27.6	27.4	24.3	21.5	19.0	16.8	14.9	13.2	24
26	24.0	24.1	24.8	24.7	24.7	24.6	24.5	24.0	21.2	18.8	16.6	14.7	13.0	26
28		21.7	22.3	22.2	22.2	22.1	22.0	21.9	21.0	18.5	16.3	14.4	12.7	28
30		19.7	20.3	20.2	20.1	20.0	19.9	19.8	19.7	18.2	16.1	14.2	12.5	30
32			18.5	18.4	18.4	18.3	18.2	18.1	18.0	17.9	15.8	13.9	12.2	32
34				17.0	16.9	16.8	16.7	16.6	16.5	16.4	15.6	13.7	12.0	34
36				15.0	15.6	15.5	15.4	15.3	15.2	15.1	14.9	13.4	11.7	36
38					14.5	14.4	14.3	14.2	14.1	13.9	13.8	13.2	11.5	38
40						13.4	13.3	13.2	13.1	12.9	12.8	12.7	11.2	40
44							11.5	11.5	11.4	11.2	11.1	11.0	10.8	44
48									10.0	9.9	9.8	9.6	9.5	48
52										8.7	8.6	8.5	8.3	52
56											6.8	7.6	7.0	56
60													5.8	60

LJ Load Chart**Load chart -LJ(Jib 22~58m, Boom angle 84°, Rear counterweight 80t, Carbody counterweight 25t) 7/11**

Boom 43m														
Radius (m)	22	25	28	31	34	37	40	43	46	49	52	55	58	Radius (m)
14	49.7	48.5												14
16	45.0	43.9	42.9	38.2										16
18	40.6	40.0	39.2	37.8	33.9	30.2	26.9							18
20	36.0	36.2	35.9	35.3	33.6	30.0	26.7	23.8	21.1					20
22	31.2	31.3	32.2	32.2	31.9	29.7	26.4	23.5	20.9	18.6	16.5	14.7		22
24	27.4	27.5	28.3	28.3	28.2	28.2	26.1	23.3	20.7	18.4	16.3	14.5	12.9	24
26	24.4	24.5	25.2	25.1	25.1	25.0	24.9	23.0	20.5	18.1	16.1	14.3	12.6	26
28		22.0	22.7	22.6	22.5	22.5	22.3	22.3	20.2	17.9	15.9	14.1	12.4	28
30		20.0	20.6	20.5	20.4	20.3	20.2	20.1	19.9	17.7	15.6	13.8	12.2	30
32			18.8	18.7	18.6	18.6	18.4	18.3	18.2	17.4	15.4	13.6	11.9	32
34				17.2	17.1	17.0	16.9	16.8	16.7	16.6	15.1	13.4	11.7	34
36				15.8	15.8	15.7	15.6	15.5	15.4	15.2	14.9	13.1	11.5	36
38					14.6	14.6	14.4	14.3	14.2	14.1	14.0	12.9	11.2	38
40						13.5	13.4	13.3	13.2	13.1	13.0	12.6	11.0	40
44							11.7	11.6	11.5	11.4	11.2	11.1	10.6	44
48								9.4	10.1	10.0	9.9	9.7	9.6	48
52										8.8	8.7	8.6	8.4	52
56											7.3	7.6	7.1	56
60													5.9	60

Load chart -LJ(Jib 22~58m, Boom angle 84°, Rear counterweight 80t, Carbody counterweight 25t) 8/11

Boom 46m														
Radius (m)	22	25	28	31	34	37	40	43	46	49	52	55	58	Radius (m)
14	47.7	45.2												14
16	43.3	42.3	40.2	36.0										16
18	39.2	38.7	38.0	35.6	32.0	28.7								18
20	35.8	35.4	34.8	34.1	31.6	28.4	25.4	22.7	20.3					20
22	31.8	32.0	32.0	31.5	30.9	28.1	25.2	22.5	20.1	17.9	16.0			22
24	27.9	28.1	28.9	28.8	28.6	27.4	24.9	22.3	19.9	17.7	15.8	14.1	12.5	24
26	24.8	24.9	25.6	25.6	25.5	25.5	24.4	22.0	19.6	17.5	15.5	13.8	12.3	26
28	22.3	22.4	23.0	23.0	22.9	22.8	22.7	21.7	19.4	17.3	15.3	13.6	12.1	28
30		20.3	20.9	20.8	20.7	20.7	20.5	20.4	19.1	17.0	15.1	13.4	11.8	30
32			19.0	19.0	18.9	18.8	18.7	18.6	18.5	16.8	14.9	13.2	11.6	32
34				17.4	17.3	17.3	17.1	17.0	16.9	16.5	14.7	13.0	11.4	34
36				16.1	16.0	15.9	15.8	15.7	15.6	15.4	14.5	12.8	11.2	36
38					14.8	14.7	14.6	14.5	14.4	14.3	14.2	12.5	11.0	38
40						13.7	13.6	13.5	13.4	13.2	13.1	12.3	10.8	40
44							11.8	11.7	11.6	11.5	11.4	11.2	10.3	44
48								9.9	10.2	10.1	10.0	9.8	9.7	48
52										8.9	8.8	8.7	8.5	52
56											7.7	7.7	7.2	56
60												5.9	6.1	60

Unit: t

LJ Load Chart

Load chart -LJ(Jib 22~58m, Boom angle 84°, Rear counterweight 80t, Carbody counterweight 25t) 9/11

Radius (m)	Boom 49m													Radius (m)
	22	25	28	31	34	37	40	43	46	49	52	55	58	
14	46.3													14
16	42.1	41.2	37.4	33.7										16
18	38.2	37.7	36.7	33.3	30.1	27.1								18
20	35.0	34.3	33.9	32.7	29.7	26.8	24.1	21.6						20
22	32.0	31.8	31.1	30.7	29.2	26.5	23.8	21.4	19.2	17.1	15.4			22
24	28.5	28.6	28.9	28.4	27.5	26.0	23.5	21.2	19.0	17.0	15.2	13.6	12.0	24
26	25.3	25.4	26.1	26.0	25.6	24.6	23.2	20.9	18.8	16.7	15.0	13.4	11.9	26
28	22.7	22.8	23.4	23.3	23.3	23.0	21.9	20.6	18.5	16.6	14.8	13.2	11.7	28
30		20.6	21.2	21.1	21.0	21.0	20.5	19.7	18.2	16.3	14.6	13.0	11.5	30
32			19.3	19.2	19.2	19.1	19.0	18.5	17.7	16.1	14.4	12.8	11.3	32
34			17.7	17.6	17.6	17.5	17.4	17.3	16.6	15.9	14.1	12.5	11.1	34
36				16.2	16.2	16.1	16.0	15.9	15.7	15.0	13.9	12.3	10.9	36
38					15.0	14.9	14.8	14.7	14.6	14.1	13.6	12.1	10.7	38
40					13.4	13.8	13.7	13.6	13.5	13.3	12.8	11.9	10.5	40
44							11.7	11.8	11.7	11.5	11.3	10.9	10.0	44
48								10.0	10.1	9.9	9.9	9.7	9.4	48
52										8.6	8.5	8.4	8.3	52
56											7.3	7.3	7.2	56
60												6.2	6.1	60

Load chart -LJ(Jib 22~58m, Boom angle 84°, Rear counterweight 80t, Carbody counterweight 25t) 10/11

Radius (m)	Boom 52m													Radius (m)
	22	25	28	31	34	37	40	43	46	49	52	55	58	
14	42.7													14
16	40.4	38.2	34.8											16
18	37.0	36.3	34.1	31.0	28.2	25.5								18
20	33.9	33.3	32.7	30.4	27.8	25.2	22.7	20.5						20
22	31.1	30.7	30.2	29.4	27.3	24.8	22.5	20.3	18.3	16.4				22
24	28.8	28.4	28.0	27.4	26.2	24.4	22.1	20.0	18.1	16.2	14.5	13.0	11.6	24
26	25.7	25.8	26.0	25.5	24.6	23.4	21.8	19.8	17.9	16.0	14.4	12.8	11.4	26
28	23.0	23.1	23.8	23.5	22.9	21.9	21.0	19.4	17.6	15.8	14.2	12.6	11.2	28
30		20.9	21.5	21.4	21.1	20.5	19.7	18.8	17.3	15.6	14.0	12.4	11.0	30
32			19.6	19.5	19.4	19.0	18.4	17.8	17.0	15.3	13.8	12.3	10.9	32
34			17.9	17.9	17.8	17.6	17.1	16.7	16.0	15.1	13.5	12.1	10.7	34
36				16.4	16.3	16.2	15.9	15.5	15.1	14.4	13.3	11.9	10.5	36
38					15.0	14.9	14.6	14.5	14.1	13.6	13.1	11.7	10.3	38
40					13.7	13.7	13.6	13.5	13.2	12.8	12.4	11.4	10.1	40
44							11.5	11.5	11.4	11.2	11.0	10.6	9.7	44
48								9.8	9.8	9.7	9.6	9.4	9.1	48
52										8.4	8.3	8.2	8.1	52
56											7.2	7.1	7.1	56
60												6.2	6.2	60

LJ Load Chart**Load chart -LJ(Jib 22~58m, Boom angle 84°, Rear counterweight 80t, Carbody counterweight 25t) 11/11**

Boom 55m														
Radius (m)	22	25	28	31	34	37	40	43	46	49	52	55	58	Radius (m)
16	38.2	35.2	32.2											16
18	36.0	34.2	31.5	28.8	26.3									18
20	33.1	32.5	30.7	28.2	25.9	23.6	21.4	19.4						20
22	30.4	29.9	29.2	27.5	25.3	23.2	21.1	19.2	17.3	15.6				22
24	28.1	27.8	27.1	26.1	24.7	22.7	20.8	18.9	17.1	15.4	13.8	12.4	11.1	24
26	26.0	25.7	25.0	24.2	23.2	22.3	20.4	18.6	16.9	15.2	13.7	12.2	10.9	26
28	23.4	23.4	22.9	22.3	21.6	20.9	19.9	18.3	16.6	15.0	13.5	12.1	10.8	28
30		21.2	20.9	20.5	20.2	19.5	18.8	17.9	16.3	14.7	13.3	11.9	10.6	30
32			19.1	18.8	18.5	18.1	17.6	16.9	16.0	14.5	13.1	11.7	10.4	32
34			17.5	17.2	17.0	16.8	16.4	15.8	15.3	14.2	12.9	11.5	10.2	34
36				15.8	15.6	15.5	15.2	14.8	14.4	13.8	12.6	11.3	10.1	36
38					14.4	14.3	14.1	13.8	13.5	13.0	12.4	11.1	9.9	38
40					13.2	13.1	13.0	12.8	12.6	12.2	11.8	10.9	9.7	40
44							11.1	11.0	10.9	10.7	10.5	10.1	9.3	44
48								9.4	9.3	9.3	9.1	8.9	8.7	48
52									8.0	8.0	7.9	7.8	7.7	52
56											6.9	6.8	6.7	56
60												5.9	5.9	60

Unit: t

LJ Load Chart

Note:

- 1.The rated load in the load chart is calculated complying with EN 13000;
- 2.The working radius is the horizontal distance from the load center to the swing center;
- 3.The actual lifting capacity must subtract the weight of hooks and other riggings from the rated capacity in the load chart.
- 4.The load value is calculated when the object is hung freely,without considering the influence of wind on the load, ground conditions and slope, operation speed and the influence of any other negative factors over safe operation. Therefore, the operator bears the responsibility of making a judgement and decreasing the load and lowering speed.
- 5.All rated values are calculated when the machine is parking on firm and level ground with less than 1% gradient.
6. See Operation Manual for load charts of LJm and LJj configurations.

Load chart -LJ(Jib 22~58m, Boom angle 75°, Rear counterweight 80t, Carbody counterweight 25t) 1/11

Radius (m)	Boom 25m												Radius (m)	
	22	25	28	31	34	37	40	43	46	49	52	55		58
20	42.8	42.8												20
22	36.2	36.4	37.3	37.1										22
24	31.3	31.4	32.2	32.1	31.9									24
26	27.5	27.6	28.3	28.2	28.0	27.9	27.7							26
28	24.5	24.6	25.2	25.1	24.9	24.8	24.6	24.5						28
30		22.1	22.7	22.5	22.4	22.3	22.1	22.0	21.9	19.2				30
32		20.0	20.6	20.4	20.3	20.2	20.0	19.9	19.8	18.9	16.5			32
34			18.8	18.7	18.6	18.4	18.3	18.1	18.0	17.8	16.3	14.2	12.4	34
36				17.2	17.1	16.9	16.8	16.6	16.5	16.3	16.0	13.9	12.1	36
38				15.8	15.7	15.6	15.4	15.3	15.2	15.0	14.9	13.7	11.9	38
40					14.6	14.5	14.3	14.2	14.0	13.9	13.8	13.4	11.6	40
44						12.1	12.4	12.3	12.2	12.0	11.9	11.7	11.2	44
48								10.8	10.6	10.5	10.4	10.2	10.1	48
52									9.3	9.3	9.1	9.0	8.8	52
56											8.1	8.0	7.8	56
60												7.1	6.6	60
64													5.4	64

Load chart -LJ(Jib 22~58m, Boom angle 75°, Rear counterweight 80t, Carbody counterweight 25t) 2/11

Radius (m)	Boom 28m												Radius (m)	
	22	25	28	31	34	37	40	43	46	49	52	55		58
20	42.5													20
22	37.8	37.7	37.5											22
24	33.0	33.2	33.7	33.4	33.3									24
26	28.8	29.0	29.8	29.8	29.7	29.6								26
28	25.5	25.7	26.4	26.3	26.3	26.2	26.0	25.0						28
30	22.9	23.0	23.7	23.6	23.5	23.4	23.3	23.1	21.7					30
32		20.8	21.4	21.3	21.3	21.2	21.0	20.9	20.7	18.7	16.3			32
34			19.5	19.4	19.3	19.3	19.1	19.0	18.8	18.5	16.1	14.0		34
36			17.9	17.8	17.7	17.6	17.5	17.4	17.2	17.1	15.9	13.8	12.0	36
38				16.4	16.3	16.2	16.1	16.0	15.8	15.7	15.5	13.6	11.8	38
40					15.1	15.0	14.9	14.8	14.6	14.5	14.3	13.3	11.6	40
44						13.0	12.9	12.7	12.6	12.5	12.3	12.2	11.1	44
48							10.9	11.2	11.0	10.9	10.7	10.6	10.5	48
52									9.7	9.6	9.5	9.3	9.2	52
56										8.5	8.4	8.2	8.1	56
60												7.3	6.9	60
64													5.8	64

LJ Load Chart**Load chart -LJ(Jib 22~58m, Boom angle 75°, Rear counterweight 80t, Carbody counterweight 25t) 3/11**

Load chart -LJ(Jib 22~58m, Boom angle 75°, Rear counterweight 80t, Carbody counterweight 25t) 3/11														
Boom 31m														
Radius (m)	22	25	28	31	34	37	40	43	46	49	52	55	58	Radius (m)
20	42.0													20
22	37.4	37.2												22
24	33.6	33.5	33.3	33.0										24
26	30.3	30.4	30.2	29.9	29.8	29.6								26
28	26.7	26.9	27.6	27.3	27.2	27.0	26.8							28
30	23.9	24.0	24.7	24.6	24.5	24.5	24.4	24.3	21.3					30
32		21.6	22.2	22.1	22.1	22.0	21.9	21.8	21.1	18.4				32
34		19.6	20.2	20.1	20.1	20.0	19.8	19.8	19.7	18.2	15.9	13.9		34
36			18.5	18.4	18.3	18.2	18.1	18.0	17.9	17.8	15.7	13.7	11.9	36
38				16.9	16.8	16.8	16.6	16.5	16.4	16.3	15.5	13.4	11.7	38
40				15.6	15.6	15.5	15.3	15.3	15.1	15.0	14.9	13.2	11.5	40
44						13.4	13.2	13.1	13.0	12.9	12.8	12.6	11.1	44
48							11.5	11.5	11.3	11.2	11.1	11.0	10.7	48
52									10.0	9.8	9.7	9.6	9.5	52
56										8.7	8.6	8.5	8.3	56
60											7.7	7.5	7.3	60
64													6.1	64

Load chart -LJ(Jib 22~58m, Boom angle 75°, Rear counterweight 80t, Carbody counterweight 25t) 4/11

Load chart -LJ(Jib 22~58m, Boom angle 75°, Rear counterweight 80t, Carbody counterweight 25t) 4/11														
Boom 34m														
Radius (m)	22	25	28	31	34	37	40	43	46	49	52	55	58	Radius (m)
22	37.0	36.8												22
24	33.2	33.1	32.9											24
26	30.2	30.0	29.8	29.6	29.4									26
28	27.6	27.4	27.2	27.0	26.8	26.7								28
30	24.9	25.0	25.0	24.8	24.7	24.5	24.2	23.8						30
32	22.4	22.5	23.1	22.9	22.8	22.6	22.4	22.2	20.7	18.1				32
34		20.4	20.9	20.9	20.8	20.7	20.6	20.5	20.4	17.9	15.7			34
36			19.1	19.0	19.0	18.9	18.8	18.7	18.6	17.7	15.5	13.5	11.8	36
38				17.4	17.4	17.3	17.2	17.1	17.0	16.8	15.3	13.3	11.6	38
40				16.1	16.0	15.9	15.8	15.7	15.6	15.5	15.1	13.1	11.4	40
44						13.7	13.6	13.5	13.4	13.3	13.1	12.7	11.0	44
48							11.8	11.8	11.6	11.5	11.4	11.3	10.6	48
52								10.3	10.2	10.1	10.0	9.9	9.7	52
56										8.9	8.8	8.7	8.6	56
60											7.8	7.7	7.6	60
64												6.9	6.4	64

Unit: t

LJ Load Chart

Load chart -LJ(Jib 22~58m, Boom angle 75°, Rear counterweight 80t, Carbody counterweight 25t) 5/11

Radius (m)	Boom 37m												Radius (m)	
	22	25	28	31	34	37	40	43	46	49	52	55		58
22	36.5													22
24	32.8	32.7	32.4											24
26	29.8	29.6	29.4	29.2										26
28	27.2	27.1	26.9	26.6	26.5	26.3								28
30	25.0	24.9	24.7	24.5	24.3	24.1	23.9							30
32	23.1	23.0	22.8	22.6	22.4	22.3	22.0	21.9	20.2					32
34		21.1	21.2	21.0	20.8	20.6	20.4	20.2	20.1	17.6	15.4			34
36			19.7	19.5	19.4	19.2	19.0	18.8	18.6	17.4	15.2	13.3		36
38			18.1	18.0	18.0	17.9	17.7	17.6	17.4	17.2	15.0	13.1	11.5	38
40				16.6	16.5	16.4	16.3	16.2	16.1	16.0	14.9	13.0	11.3	40
44					14.2	14.1	14.0	13.9	13.8	13.6	13.5	12.6	10.9	44
48							12.2	12.1	11.9	11.8	11.7	11.6	10.5	48
52								10.6	10.5	10.3	10.2	10.1	10.0	52
56									9.3	9.1	9.0	8.9	8.8	56
60											8.0	7.9	7.8	60
64												7.0	6.6	64

Load chart -LJ(Jib 22~58m, Boom angle 75°, Rear counterweight 80t, Carbody counterweight 25t) 6/11

Radius (m)	Boom 40m												Radius (m)		
	22	25	28	31	34	37	40	43	46	49	52	55		58	
22	36.0													22	
24	32.4	32.2												24	
26	29.4	29.2	29.0	28.7										26	
28	26.8	26.7	26.5	26.2	26.1									28	
30	24.7	24.5	24.3	24.1	23.9	23.8	23.5							30	
32	22.8	22.7	22.5	22.3	22.1	21.9	21.7	21.5						32	
34		21.0	20.9	20.6	20.5	20.3	20.1	19.9	19.6	17.2				34	
36		19.6	19.4	19.2	19.1	18.9	18.7	18.5	18.3	17.0	14.9	13.1		36	
38			18.2	18.0	17.8	17.7	17.4	17.3	17.1	16.9	14.7	12.9	11.3	38	
40				16.8	16.7	16.5	16.3	16.2	16.0	15.8	14.6	12.7	11.1	40	
44					14.6	14.5	14.4	14.3	14.1	13.9	13.7	12.4	10.7	44	
48							12.6	12.5	12.4	12.3	12.1	12.0	11.9	10.4	48
52									10.9	10.7	10.6	10.5	10.4	10.1	52
56										9.5	9.4	9.2	9.1	9.0	56
60												8.2	8.1	7.9	60
64													7.2	7.0	64
68														5.8	68

LJ Load Chart**Load chart -LJ(Jib 22~58m, Boom angle 75°, Rear counterweight 80t, Carbody counterweight 25t) 7/11**

Boom 43m														
Radius (m)	22	25	28	31	34	37	40	43	46	49	52	55	58	Radius (m)
24	31.9	31.7												24
26	28.9	28.8	28.6											26
28	26.4	26.3	26.1	25.8	25.6									28
30	24.3	24.2	24.0	23.7	23.6	23.4								30
32	22.5	22.3	22.1	21.9	21.7	21.6	21.3	21.1						32
34	20.8	20.7	20.5	20.3	20.2	20.0	19.7	19.6	19.0					34
36		19.3	19.1	18.9	18.8	18.6	18.4	18.2	18.0	16.5	14.6			36
38			17.9	17.7	17.5	17.4	17.1	17.0	16.8	16.4	14.4	12.7	11.1	38
40			16.8	16.6	16.4	16.3	16.0	15.9	15.7	15.5	14.3	12.5	10.9	40
44					14.5	14.4	14.2	14.0	13.8	13.6	13.5	12.2	10.6	44
48						12.8	12.6	12.5	12.3	12.1	11.9	11.8	10.3	48
52								11.1	11.0	10.8	10.6	10.5	10.0	52
56									9.7	9.6	9.5	9.3	9.2	56
60										8.5	8.4	8.3	8.1	60
64												7.4	7.2	64
68													6.0	68

Load chart -LJ(Jib 22~58m, Boom angle 75°, Rear counterweight 80t, Carbody counterweight 25t) 8/11

Boom 46m														
Radius (m)	22	25	28	31	34	37	40	43	46	49	52	55	58	Radius (m)
24	31.4													24
26	28.5	28.4												26
28	26.1	25.9	25.7	25.4										28
30	24.0	23.8	23.6	23.3	23.2	23.0								30
32	22.1	22.0	21.8	21.6	21.4	21.2	20.9							32
34	20.5	20.4	20.2	20.0	19.8	19.7	19.4	19.2	18.3					34
36		19.0	18.9	18.6	18.5	18.3	18.0	17.9	17.7	16.0				36
38		17.8	17.6	17.4	17.2	17.1	16.8	16.7	16.5	15.9	14.0	12.4		38
40			16.5	16.3	16.2	16.0	15.8	15.6	15.4	15.2	13.9	12.2	10.7	40
44					14.3	14.1	13.9	13.8	13.6	13.3	13.2	11.9	10.4	44
48						12.6	12.4	12.2	12.1	11.8	11.7	11.5	10.1	48
52							11.1	11.0	10.8	10.6	10.4	10.3	9.8	52
56									9.7	9.5	9.4	9.2	9.0	56
60										8.6	8.4	8.3	8.0	60
64											7.6	7.4	7.2	64
68													6.2	68

Unit: t

LJ Load Chart

Load chart -LJ(Jib 22~58m, Boom angle 75°, Rear counterweight 80t, Carbody counterweight 25t) 9/11

Radius (m)	Boom 49m													Radius (m)
	22	25	28	31	34	37	40	43	46	49	52	55	58	
26	28.1	27.8												26
28	25.6	25.5	25.3											28
30	23.6	23.4	23.2	22.9	22.7									30
32	21.8	21.6	21.4	21.2	21.0	20.8	20.4							32
34	20.2	20.1	19.9	19.6	19.5	19.3	19.0	18.8						34
36	18.8	18.7	18.5	18.3	18.1	17.9	17.7	17.5	17.3	15.5				36
38		17.5	17.3	17.1	16.9	16.8	16.5	16.3	16.2	15.4	13.6			38
40			16.2	16.0	15.9	15.7	15.4	15.3	15.1	14.9	13.5	11.9	10.4	40
44				14.1	14.0	13.9	13.6	13.5	13.3	13.1	12.9	11.6	10.1	44
48						12.3	12.1	12.0	11.8	11.6	11.4	11.2	9.9	48
52							10.9	10.7	10.6	10.3	10.2	10.0	9.6	52
56								9.6	9.5	9.3	9.1	9.0	8.7	56
60										8.4	8.2	8.0	7.8	60
64											7.4	7.3	7.0	64
68													6.3	68

Load chart -LJ(Jib 22~58m, Boom angle 75°, Rear counterweight 80t, Carbody counterweight 25t) 10/11

Radius (m)	Boom 52m													Radius (m)
	22	25	28	31	34	37	40	43	46	49	52	55	58	
26	27.4													26
28	25.2	25.0	24.6											28
30	23.2	23.0	22.8	22.4										30
32	21.4	21.3	21.0	20.8	20.6	20.2								32
34	19.9	19.7	19.5	19.3	19.1	18.9	18.5	18.2						34
36	18.5	18.4	18.2	17.9	17.8	17.6	17.3	17.1	16.7					36
38		17.2	17.0	16.8	16.6	16.4	16.2	16.0	15.8	14.7	13.1			38
40			15.9	15.7	15.6	15.4	15.1	15.0	14.8	14.5	13.0	11.5		40
44				13.9	13.7	13.6	13.3	13.2	13.0	12.8	12.6	11.2	9.8	44
48					12.2	12.1	11.9	11.7	11.5	11.3	11.1	11.0	9.6	48
52							10.6	10.5	10.3	10.1	9.9	9.8	9.4	52
56								9.4	9.3	9.0	8.9	8.7	8.5	56
60									8.3	8.1	8.0	7.8	7.6	60
64											7.2	7.1	6.8	64
68												6.4	6.2	68

LJ Load Chart

Load chart -LJ(Jib 22~58m, Boom angle 75°, Rear counterweight 80t, Carbody counterweight 25t) 11/11

Boom 55m														
Radius (m)	22	25	28	31	34	37	40	43	46	49	52	55	58	Radius (m)
26	26.6													26
28	24.6	24.3												28
30	22.7	22.6	22.2	21.7										30
32	21.0	20.8	20.6	20.3	19.9									32
34	19.5	19.3	19.1	18.9	18.7	18.3	17.9							34
36	18.1	18.0	17.8	17.6	17.4	17.2	16.8	16.5	15.8					36
38		16.8	16.7	16.4	16.3	16.1	15.8	15.5	15.2	14.0				38
40		15.8	15.6	15.4	15.2	15.0	14.8	14.6	14.3	13.9	12.4	11.0		40
44				13.6	13.4	13.3	13.0	12.9	12.7	12.4	12.2	10.8	9.5	44
48					12.0	11.8	11.6	11.4	11.3	11.0	10.9	10.6	9.3	48
52						10.6	10.4	10.2	10.1	9.8	9.7	9.5	9.1	52
56								9.2	9.0	8.8	8.7	8.5	8.3	56
60									8.1	7.9	7.8	7.6	7.4	60
64											7.0	6.8	6.6	64
68												6.2	6.0	68
72													5.3	72

Unit: t

LJ Load Chart

Note:

- 1.The rated load in the load chart is calculated complying with EN 13000;
- 2.The working radius is the horizontal distance from the load center to the swing center;
- 3.The actual lifting capacity must subtract the weight of hooks and other riggings from the rated capacity in the load chart.
- 4.The load value is calculated when the object is hung freely,without considering the influence of wind on the load, ground conditions and slope, operation speed and the influence of any other negative factors over safe operation. Therefore, the operator bears the responsibility of making a judgement and decreasing the load and lowering speed.
- 5.All rated values are calculated when the machine is parking on firm and level ground with less than 1% gradient.
6. See Operation Manual for load charts of LJm and LJn configurations.

Load chart -LJ(Jib 22~58m, Boom angle 65°, Rear counterweight 80t, Carbody counterweight 25t) 1/11

Radius (m)	Boom 25m													Radius (m)
	22	25	28	31	34	37	40	43	46	49	52	55	58	
26	28.4													26
28	26.2	26.0												28
30	24.1	24.0	23.7											30
32	22.3	22.2	21.9	21.7										32
34	20.7	20.7	20.5	20.1	20.0									34
36		19.2	19.1	18.8	18.7	18.4	18.1							36
38			17.8	17.6	17.4	17.3	17.0	16.7						38
40				16.4	16.3	16.1	15.9	15.7	15.5					40
44					14.4	14.3	14.0	13.9	13.7	13.4	13.3			44
48						12.6	12.4	12.3	12.1	11.9	11.7	11.4	10.1	48
52								10.8	10.7	10.5	10.4	10.2	9.8	52
56									9.4	9.3	9.1	9.0	8.8	56
60										8.2	8.1	8.0	7.8	60
64												7.1	7.0	64
68													6.0	68

Load chart -LJ(Jib 22~58m, Boom angle 65°, Rear counterweight 80t, Carbody counterweight 25t) 2/11

Radius (m)	Boom 28m													Radius (m)
	22	25	28	31	34	37	40	43	46	49	52	55	58	
28	25.9													28
30	23.9	23.6												30
32	22.0	21.9	21.6	21.4										32
34	20.5	20.4	20.1	19.8	19.7									34
36		19.0	18.8	18.6	18.3	18.1								36
38		17.7	17.6	17.3	17.2	17.0	16.6							38
40			16.4	16.2	16.1	15.9	15.6	15.4						40
44					14.2	14.0	13.8	13.6	13.4	13.1				44
48						12.5	12.2	12.1	11.9	11.7	11.4	11.2	10.0	48
52							10.9	10.8	10.6	10.4	10.2	10.0	9.7	52
56									9.5	9.2	9.1	8.9	8.6	56
60										8.3	8.2	8.0	7.7	60
64											7.3	7.1	6.9	64
68													6.1	68

LJ Load Chart**Load chart -LJ(Jib 22~58m, Boom angle 65°, Rear counterweight 80t, Carbody counterweight 25t) 3/11**

Boom 31m														
Radius (m)	22	25	28	31	34	37	40	43	46	49	52	55	58	Radius (m)
30	23.3	23.2												30
32	21.6	21.5	21.2											32
34	20.1	19.9	19.7	19.4										34
36	18.8	18.7	18.4	18.1	17.9									36
38		17.4	17.2	17.0	16.7	16.5								38
40			16.1	15.9	15.7	15.5	15.3							40
44				14.0	13.9	13.7	13.5	13.3	13.0	12.7				44
48					12.3	12.2	12.0	11.8	11.6	11.3	11.1	10.9		48
52							10.7	10.5	10.3	10.1	9.9	9.6	9.4	52
56								9.4	9.2	9.0	8.8	8.6	8.4	56
60										8.1	7.8	7.7	7.4	60
64											7.1	6.9	6.7	64
68												6.1	5.9	68

Load chart -LJ(Jib 22~58m, Boom angle 65°, Rear counterweight 80t, Carbody counterweight 25t) 4/11

Boom 34m														
Radius (m)	22	25	28	31	34	37	40	43	46	49	52	55	58	Radius (m)
30	23.0													30
32	21.3	21.1												32
34	19.8	19.6	19.4											34
36	18.4	18.3	18.1	17.8										36
38		17.1	17.0	16.6	16.4	16.2								38
40		16.0	15.9	15.6	15.4	15.2	14.9							40
44				13.8	13.6	13.5	13.1	12.9	12.7					44
48					12.1	12.0	11.7	11.4	11.2	11.0	10.8			48
52						10.6	10.4	10.3	10.1	9.8	9.6	9.4	9.1	52
56								9.2	9.0	8.7	8.6	8.4	8.1	56
60									8.1	7.8	7.6	7.4	7.2	60
64											6.9	6.7	6.5	64
68												5.9	5.7	68
72													5.1	72

Unit: t

LJ Load Chart

Load chart -LJ(Jib 22~58m, Boom angle 65°, Rear counterweight 80t, Carbody counterweight 25t) 5/11

Boom 37m														
Radius (m)	22	25	28	31	34	37	40	43	46	49	52	55	58	Radius (m)
32	20.8													32
34	19.3	19.2												34
36	18.0	17.8	17.6	17.3										36
38	16.9	16.7	16.4	16.2	16.0									38
40		15.7	15.5	15.2	14.9	14.7								40
44			13.7	13.4	13.3	13.0	12.7	12.5						44
48					11.8	11.6	11.3	11.1	10.9	10.6	10.4			48
52						10.4	10.1	10.0	9.8	9.4	9.2	9.0	8.7	52
56							9.0	8.9	8.7	8.4	8.3	8.1	7.7	56
60									7.7	7.5	7.3	7.1	6.9	60
64										6.8	6.6	6.4	6.1	64
68											5.8	5.7	5.4	68
72													4.9	72

Load chart -LJ(Jib 22~58m, Boom angle 65°, Rear counterweight 80t, Carbody counterweight 25t) 6/11

Boom 40m														
Radius (m)	22	25	28	31	34	37	40	43	46	49	52	55	58	Radius (m)
32	20.2													32
34	18.9	18.7												34
36	17.6	17.4	17.2											36
38	16.4	16.2	16.0	15.7										38
40	15.4	15.3	15.1	14.7	14.5									40
44			13.3	13.0	12.8	12.6	12.3	12.1						44
48				11.6	11.4	11.2	10.9	10.7	10.5	10.2				48
52						10.0	9.8	9.5	9.3	9.1	8.9	8.7		52
56							8.7	8.6	8.4	8.1	7.8	7.6	7.4	56
60								7.6	7.5	7.2	7.0	6.8	6.6	60
64										6.5	6.3	6.0	5.8	64
68											5.6	5.4	5.2	68
72												4.8	4.6	72

LJ Load Chart**Load chart -LJ(Jib 22~58m, Boom angle 65°, Rear counterweight 80t, Carbody counterweight 25t) 7/11**

Boom 43m														
Radius (m)	22	25	28	31	34	37	40	43	46	49	52	55	58	Radius (m)
34	18.2													34
36	17.1	16.9												36
38	15.9	15.8	15.5											38
40	14.9	14.7	14.5	14.2										40
44		13.0	12.8	12.5	12.4	12.2	11.9							44
48				11.1	11.0	10.8	10.5	10.3	10.1					48
52					9.9	9.6	9.3	9.1	8.9	8.7	8.5			52
56						8.6	8.4	8.2	8.0	7.7	7.5	7.3	7.0	56
60								7.3	7.1	6.9	6.7	6.5	6.1	60
64									6.4	6.1	5.9	5.7	5.5	64
68											5.3	5.1	4.9	68
72												4.6	4.2	72
76													3.7	76

Load chart -LJ(Jib 22~58m, Boom angle 65°, Rear counterweight 80t, Carbody counterweight 25t) 8/11

Boom 46m														
Radius (m)	22	25	28	31	34	37	40	43	46	49	52	55	58	Radius (m)
36	16.5													36
38	15.5	15.3	15.1											38
40	14.5	14.3	14.1	13.8										40
44		12.7	12.5	12.2	12.0	11.8								44
48			11.0	10.8	10.6	10.4	10.1	9.9						48
52					9.4	9.3	9.0	8.8	8.6	8.3	8.1			52
56						8.3	8.1	7.8	7.6	7.3	7.1	6.9	6.7	56
60							7.2	7.0	6.8	6.6	6.4	6.1	5.8	60
64									6.1	5.8	5.6	5.4	5.2	64
68										5.2	5.0	4.8	4.6	68
72												4.2	4.0	72
76													3.5	76

Unit: t

LJ Load Chart

Load chart -LJ(Jib 22~58m, Boom angle 65°, Rear counterweight 80t, Carbody counterweight 25t) 9/11

Boom 49m														
Radius (m)	22	25	28	31	34	37	40	43	46	49	52	55	58	Radius (m)
36	16.0													36
38	14.9	14.7												38
40	14.0	13.8	13.6											40
44	12.3	12.2	12.0	11.7	11.4									44
48			10.6	10.4	10.2	10.0	9.6	9.4						48
52				9.2	9.1	8.9	8.6	8.4	8.2	7.8				52
56						8.0	7.6	7.4	7.2	6.9	6.7	6.5		56
60							6.8	6.7	6.5	6.1	5.9	5.7	5.4	60
64								5.9	5.7	5.5	5.3	5.1	4.8	64
68										4.9	4.7	4.5	4.2	68
72											4.1	3.9	3.7	72
76												3.4	3.2	76

Load chart -LJ(Jib 22~58m, Boom angle 65°, Rear counterweight 80t, Carbody counterweight 25t) 10/11

Boom 52m														
Radius (m)	22	25	28	31	34	37	40	43	46	49	52	55	58	Radius (m)
38	14.4													38
40	13.5	13.3												40
44	11.9	11.8	11.4	11.1	10.9									44
48		10.4	10.2	9.9	9.8	9.4	9.1							48
52				8.8	8.7	8.5	8.2	8.0	7.7					52
56					7.7	7.5	7.2	7.0	6.8	6.5	6.3	6.0		56
60							6.5	6.3	6.0	5.7	5.5	5.3	5.0	60
64								5.6	5.4	5.1	4.9	4.7	4.5	64
68									4.8	4.6	4.3	4.1	3.8	68
72											3.8	3.6	3.3	72
76												3.2	2.9	76
80													2.4	80

LJ Load Chart

Load chart -LJ(Jib 22~58m, Boom angle 65°, Rear counterweight 80t, Carbody counterweight 25t) 11/11

Boom 55m														
Radius (m)	22	25	28	31	34	37	40	43	46	49	52	55	58	Radius (m)
40	12.8	12.6												40
44	11.3	11.1	10.9	10.6										44
48		10.0	9.8	9.4	9.2	8.9								48
52			8.6	8.4	8.2	8.0	7.6	7.4	7.2					52
56					7.3	7.1	6.8	6.6	6.4	6.0	5.8			56
60						6.4	6.0	5.8	5.6	5.3	5.1	4.9	4.6	60
64							5.4	5.2	5.0	4.7	4.5	4.2	4.0	64
68									4.5	4.1	3.9	3.7	3.4	68
72										3.6	3.5	3.3	3.0	72
76												2.8	2.5	76
80													2.1	80



Zhejiang Sany Equipment Co.,LTD

SANY Crawler Crane Industrial Park, No. 2188 Daishan Road, Wuxing District, Huzhou City,
Zhejiang Province, P. R. China Zip 313028
Consulting sanycrane@sanygroup.com (Crane BU) / crd@sany.com.cn (IHQ)
After-sales Service 0086-400 6098 318

Reminder:

Any change in the technical parameters and configuration due to product modification or upgrade may occur without prior notice.
The machine in the picture may include additional equipment. This brochure is for reference only, and goods in kind shall prevail.
Copyright at SANY. No part of this brochure may be copied or used for any purpose without written approval from SANY.

© Edited in February 2024

