



SCC300TB

Telescopic Crawler Crane 30 Tons Lifting Capacity

Quality Changes the World



Max. lifting moment: 125t·m
Max. boom length: 42.5m
Max. boom + jib length: 42.5m+8m

The parameters, pictures and standard/optional equipment are only for reference in this brochure, the actual machine is based on the effective price list and contract.



Telescopic Crawler Crane SCC300TB

P03

Main characteristics

- Product Specification
- Safety Device

P08

Technical parameters

- Major Performance & Specifications
- Outline Dimension
- Transport Dimension
- Transport Plan
- Self-assembly and self-disassembly plan

P13

Cofigurations

- Working range of H
- Load Chart of H
- Load Chart of FJ



SCC300TB
TELESCOPIC CRAWLER CRANE
30 TONS LIFTING CAPACITY

QUALITY CHANGES THE WORLD

Main Characteristics

- Page 04 Product Specification
- Page 06 Safety Devices



Product Specification



Engine

- Model: ISUZU 4HK1XKSC diesel engine.
- Type: Four-stroke, water cooling, straight 4-cylinder, direct injection, turbo supercharging, inter-cooling. Meet non-road emission regulation of Europe (Tier III), and comply with non-road emission regulation of China (Tier III).
- Displacement: 5.19L.
- Rated power: 133kW/2000rpm.
- Maximum torque: 657N · m/1500rpm.
- Starting device: 24V-5.0kW.
- Radiator: Aluminium sheet fin type radiator core.
- Air filter: Dry type air filter system, fitted with main filter element, safety filter element and resistance indicator.
- Hand throttle: Gear type hand throttle, electric.
- Fuel filter: Replaceable paper filter element.
- Battery: Two 12Vx165Ah capacity batteries, connected in series;
- Fuel tank: 400L.

Electrical control system

- Adopt SYIC-II integrated control system independently researched and developed by Sany. This system is featured by high integration level, accurate operation and reliable quality.
- Control system: Composed of power system, engine system, main control system, Load Moment Limiter, auxiliary system and safety monitoring system. Data communication among controller, display and engine is conducted by CAN bus technology.
- Display: It can display the engine rotating speed, fuel volume, engine oil pressure, servo pressure, engine working time, load weight, boom angle and other working parameters and working conditions.

Hydraulic system

- Main pump: Adopt open piston pump with large variable displacement, providing oil supply to the main actuator.
- Gear pump: Dual gear pump for slewing, and control circuit.
- Control: The main pump adopts the control type of electrically proportionate positive flow, and the winch motor is piston motor with variable displacement. The operating components are two hydraulically-controlled cross handles, one hydraulic control pedal valve for boom telescoping, and one dual pedal control valve for travel, to control each actuator proportionally.
- Max. pressure of system:
Main load, aux. load, and travel system: 32MPa.
Boom hoist cylinder lifting: 32MPa.
Slewing system: 24MPa.
Control system: 4.5MPa.
- Hydraulic oil tank capacity: 650L.

Main and aux. load hoist mechanism

- Pump and motor: Energy-efficient, combination of winch balance valve and anti-hook sliding technology, lifting or lowering the load steadily.
- Winch brake adopts wet type and spring loaded fin type normally engaged brake, spring force braking, oil pressure released.
- Main and aux. load hoist winches adopt piston motor of fixed displacement to drive planetary reducer.

Main lifting mechanism	Rope speed (outermost layer)	0~140m/min
	Diameter of wire rope	Φ16mm
	Overall length of wire rope	220m
	Rated tensile force of single rope	4.1t
Auxiliary lifting mechanism	Rope speed (outermost layer)	0~125m/min
	Diameter of wire rope	Φ16mm
	Overall length of wire rope	110m
	Rated tensile force of single rope	4.1t

Boom hoist mechanism

- Double acting single piston rod hydraulic cylinder, fitted with safety balance valve, luffing angle: -2°~78°, adopting dead-weight luffing system to reduce the energy consumption and improve the steadiness of luffing operation.

Slewing mechanism

- Slewing brake adopts wet type and spring loaded fin type normally engaged brake, spring force braking.
- With integrated cushion valve, the slewing system has free slip function to realize steady slewing start and control, showing outstanding microinching performance.
- Unique slewing cushion design ensures more stable braking.
- Slewing drive: External gearing slewing drive, capable of conducting 360° rotation, maximum rotation speed 2r/min. The maximum driving pressure can reach 20MPa.
- Slewing lockout: Locking device, to ensure that the superstructure can be locked in front and rear directions conveniently and reliably during off-work time and transportation.
- Slewing bearing: Single row ball type bearing.



Product Specification

Counterweight

- Rear counterweight: gross weight 11t.
- Provide load chart of no counterweight.

Superstructure

- High strength steel welding frame structure, no torsional deformation, reasonable component layout, and convenient maintenance service.

Cab and control

- Novelty in cab design, artistic modeling and trim and large area glass window with a tilt angle of 20° to broaden horizon; fitted with low beam headlamp and rearview mirror to broaden horizon; installed with air conditioner and radio; the arrangement of seats, control handle and various control buttons is ergonomically designed to enable more conformable operation.
- Cab layout: Integrated touch screen of large dimension, vibration handles are offered as optional and man-machine interaction interface are more perfect.
- Armrest box: Operation handle, electrical switch, emergency stop switch and ignition switch are installed on the left and right armrest boxes. The armrest box can be adjusted with the seat.
- Seat: Suspension type multi-mode multi-level regulated seat, fitted with unloading switch.
- Air conditioner: Cooling and heating air, optimized air passage and air port.
- Multiple cameras can be presented on the monitor at the same time to realize real-time monitoring of wire rope on each winch, conditions behind the counterweight and surrounding the machine.

Traveling drive

- Independent traveling drive device is adopted for each side of crawler frame, so as to realize straight travel, turning through reducer and drive wheel by travel motor. And the machine is capable of cab auto direction aligning.
- Traveling speed: The traveling can be switched between high speed and low speed, and the high speed can be up to 2.6km/h.
- Gradeability: 45%.

Traveling braking

- Concealed wet type and spring loaded fin type normally engaged brake, spring force braking, oil pressure released.

Telescopic crawler

- The extension and retraction of crawler frames are realized through cylinder. The crawlers are extended at work and retracted for transport with the whole basic machine.
- The crawlers can work in fully extended and fully retracted conditions, and respective hierarchical load chart is provided.

Crawler tensioning

- Spring tensioner with auxiliary hydraulic cylinder regulates the tension degree through charging grease, and the spring can perform buffer and protection function when traveling.

Steering system

- It can realize single track turning and pivot turning.

Track shoe

- Excavator three-reinforcement chain link track shoe is adopted, which is made of high strength alloy cast steel, has stronger road holding capacity and longer service life, and can adapt to various harsh road conditions. Width 700mm, Qty 60×2.

Track roller

- Maintenance-free track roller.

Product Specification



Main boom

- The boom is made of high-strength steel structure with U-shape section area, with four sections, of which the basic boom is 10.9m and the max. boom length is 42.5m.
- Dual cylinders and rope row for boom telescoping.

Fixed jib

- One FJ configurations: 8m.
- Installation angle includes 0°, 15° and 30°.

Boom tip pulley

- Welding structure, connected with the boom through pin, and used for auxiliary hook operation.

Lifting hook

Name	Capacity (t)	Pulley block	Weight (t)	Quantity
1	30	4	0.32	1
2	5	1	0.09	1

Note: the above-mentioned operating equipment is full-up configuration. The actual configurations are subject to contract.

Hook limitation height

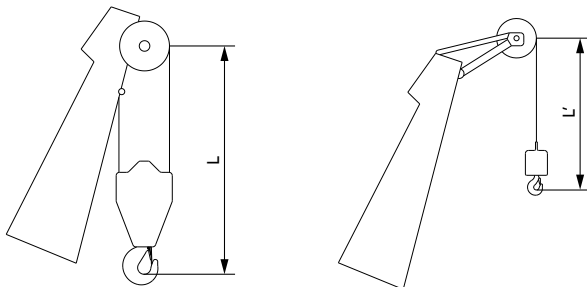

Hook	L	Hook	L'
30t	3m	5t	2.3m

Safety Device



Smart integrated load moment indicator

- The integrated LMI system is provided as standard offering to realize calibration-free and high safety and efficiency for equipment control.
- The LMI system can automatically detect the suspended load weight, working radius of the crane and the angle of boom, and compare rated load weight and actual load, working radius and boom angle. Under normal operation condition, it can intelligently judge and automatically cut off the crane action in dangerous direction, and have black box function to record the overload information.
- Its main components include: Monitor, controller, length and angle sensor, pressure sensor, etc.

Assembly/working mode switching switch

- In assembly mode, certain safety devices are disabled to facilitate crane assembly.
- In work mode, all safety limiting devices activate to protect the operation.

Emergency stop

- In emergency situation, this button is pressed down to cut off the power supply of the whole machine and all actions stop.

Over-hoist protection of the main/auxiliary load hoist

- Height limiter is equipped on the boom/jib tip, which prevents the hook lifting up too much. When the hook is lifted up to the limit height, the limit switch activates, alarm pops up on the monitor, buzzer on the right front control panel sends alarm, failure indicator light starts to flash and the hook hoisting action is cut off automatically.

Over-release protection of the main/auxiliary load hoist

- Three-wrap protector is installed on main and aux. load hoist to prevent over-release of wire rope. When the rope is paid out close to the last three wraps, the limit switch acts, and the system sends alarm through buzzer and show the alarm on the monitor, automatically cutting off the winch action.



Safety Device

Function lock

- If the function lock lever is not in work position, all the other handles won't work, which prevents any mis-operation caused by accidental hitting.

Slewing lock

- Electrical lock is provided, which needs to be released for slewing to work, so as to prevent operator accidentally hit the handle and ensure the safety.
- Cylinder lock can lock the upperworks at two directions.

Hook latch

- The lifting hook is installed with a baffle plate to prevent wire rope from falling off.

GPS monitoring system

- Standard remote monitoring system: It can provide functions like GPS locating, GPRS data transfer, machine status inquiry and statistics, operating data monitoring and analysis, and remote diagnosis of failures.

Tri-color load indicator

- The load indicator light has three colors, i.e., green, yellow and red; and the real time load status is presented on the display. When the actual load is smaller than 90% of rated load, the green light is on; when the actual load is larger than 90% and smaller than 100%, the yellow light is on, the alarm light flashes and sends out intermittent sirens; when the actual load reaches 100% of rated load, the red light is on, the alarm light flashes and sends out continuous sirens. When the actual load reaches 102%, the system will automatically cut off the crane's dangerous operation.

Flash alarm

- When the LMI is powered on, the flash alarm will turn on.

Slewing indicator light

- The slewing indicator light flashes during traveling or slewing.

Seat interlock

- If the operator leaves the seat, all control handles and switches will be disabled immediately to prevent any mis-operation due to accidental collision.

Illuminating light

- The machine is equipped with short-beam light in front of machine, lamps in operator's cab and lighting devices for night operation, as well as boom lights, so as to increase the visibility during work.

Rearview mirror

- It is installed on the left of the operator's cab and at the front handrail of the sheet metal for monitoring the rear part of the machine.

Level indicator

- Electrical level indicator can show the inclination angle of superstructure on the monitor.

Closed circuit monitoring system

- There are two cameras on the tail of rotating bed, which can show the rear part and winches working on the machine.



SCC300TB
TELESCOPIC CRAWLER CRANE
30 TONS LIFTING CAPACITY

QUALITY CHANGES THE WORLD

Technical Parameters

- Page 09 Major Performance & Specifications
- Page 10 Outline Dimension
- Page 11 Transport Dimension
- Page 12 Transport Plan

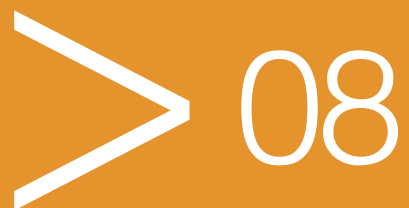

Major Performance & Specifications

Major Performance & Specifications of SCC300TB			
Specification		Unit	Parameter
Outline dimension	Full length of the whole crane	mm	13937
	Width of the whole machine (retracted)	mm	4500 (3000)
	Height of the whole machine	mm	3498
	Center distance of driving and engaged wheels	mm	4872
	Width of track shoe	mm	700
H (main boom) configuration	Maximum rated lifting weight	t	30
	Main boom length	m	10.9~42.5
	Main boom angle	°	-2~78
	Maximum rated lifting moment	t·m	125
FJ(fixed jib) configuration	Longest main boom + longest jib	m	42.5+8
	Included angle between main boom and jib	°	0, 15, 30
Working speed	Main load hoist rope speed	m/min	0~140
	Aux. load hoist rope speed	m/min	0~125
	Time to fully boom up/down	s	35/45
	Time to fully extend/retract boom	s	50/50
	Slewing speed	rpm	0~2.5
	No-load traveling speed	km/h	0~3.0
Engine	Model		ISUZU 4HK1XKSC
	Rated power	kW/rpm	133/2000
Wire rope	Diameter	mm	Φ 16
Transportation parameters	Weight of the whole machine	t	41
	Maximum weight of single piece transportation	t	30 (remove counterweight)
	Transportation dimension (L×W×H)	mm	13408×3000×3188
Other Parameters	Average ground bearing pressure	MPa	0.06
	Min. slewing radius	mm	3703

Outline Dimension

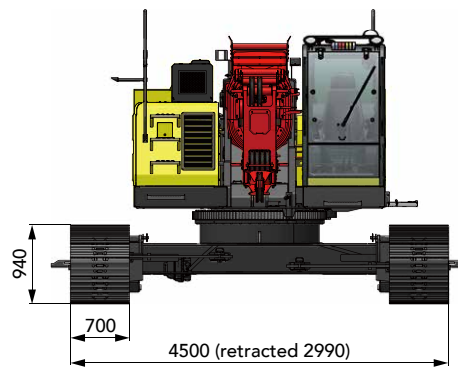
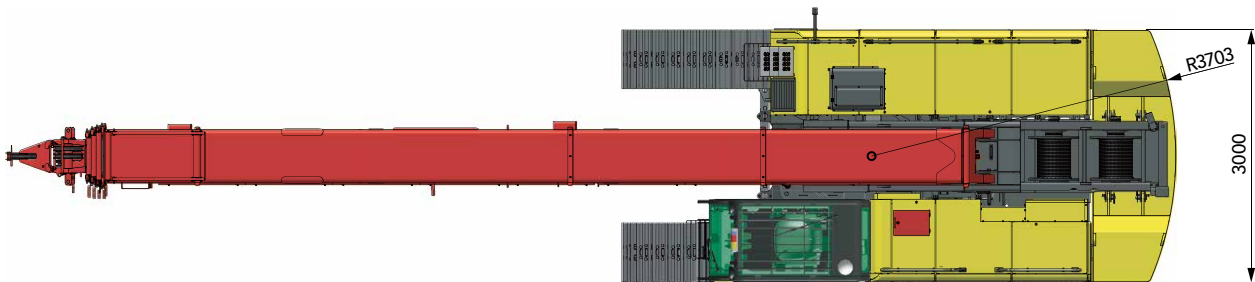
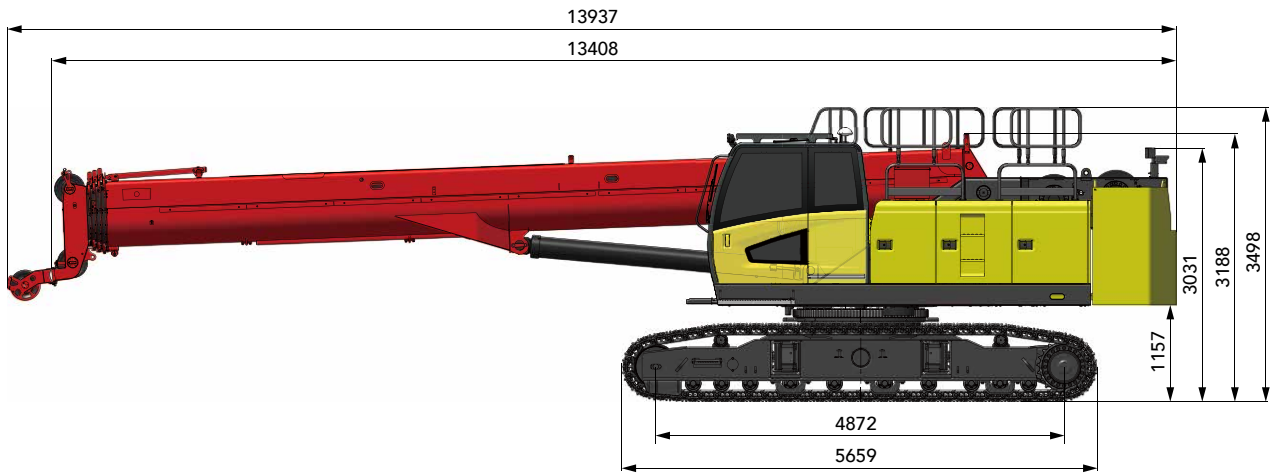

Transport Dimension

Note:

- ① . The component transportation dimension is schematic diagram, and is not drawn to scale. The marked dimension is design value, excluding the package.
- ② . The weight is design value, which may be slightly different because of manufacturing tolerance. The total weight of counterweight is 10t.
- ③ . After product upgrading of the Company, the outline dimension and weight of the components above may vary, and the new product shall prevail.

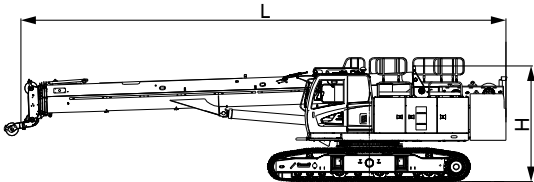

Whole machine ×1

Length (L)	13.41m
Width (W)	3.00m
Height (H)	3.19m
Weight	41.0t

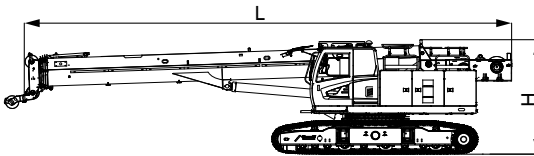

Basic machine (without counterweight) ×1

Length (L)	13.39m
Width (W)	3.00m
Height (H)	3.19m
Weight	30.0t

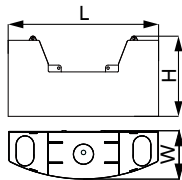

Rear counterweight block ×1

Length (L)	3.00m
Width (W)	0.97m
Height (H)	1.61m
Weight	11.0t

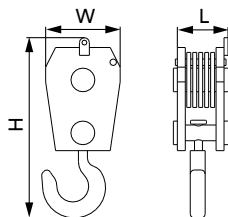

30t hook ×1

Length (L)	0.33m
Width (W)	0.44m
Height (H)	1.10m
Weight	0.32t

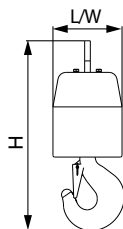

5t hook ×1

Length (L)	0.24m
Width (W)	0.24m
Height (H)	0.66m
Weight	0.09t

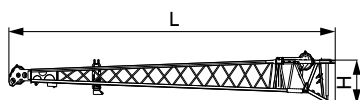

8m jib (optional) ×1

Length (L)	8.27m
Width (W)	0.69m
Height (H)	0.95m
Weight	0.43t

Transport plan

■ Transportation mode I:

Whole machine transportation, gross weight 41t, 13.41m×3.00m×3.19m (L×W×H)

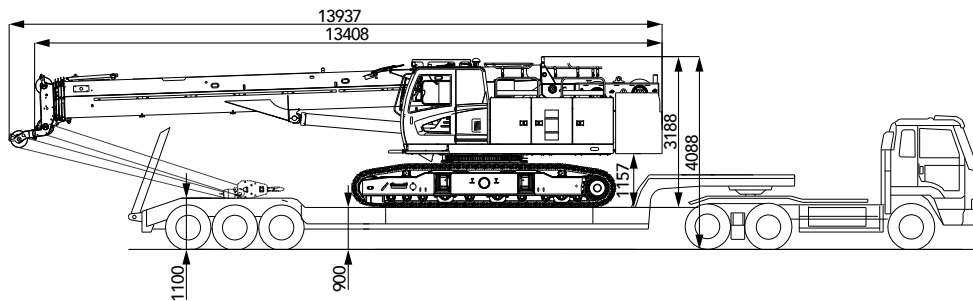

■ Transportation mode II:

Dismantle the counterweight, transport through two vehicles with maximum weight of single piece

Transportation 1: Whole machine without counterweight, gross weight 30t, 13.39m×3.00m×3.19m (L×W×H)

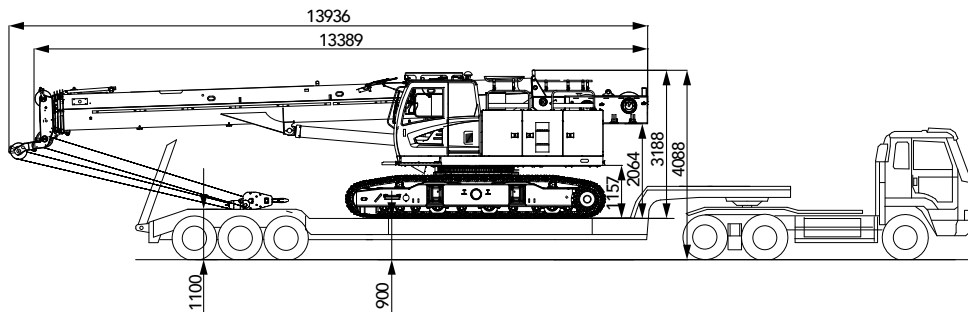

Transportation 2: Counterweight, gross weight 11t, 3.00m×0.97×1.61m (L×W×H)

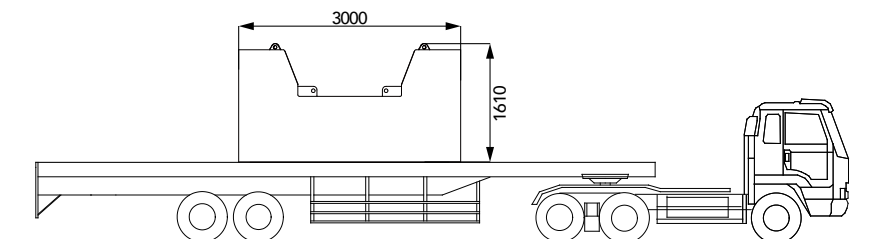



SCC300TB
TELESCOPIC CRAWLER CRANE
30 TONS LIFTING CAPACITY

QUALITY CHANGES THE WORLD

Cofigurations

- Page 14 Working range of H
- Page 15 Load Chart of H
- Page 17 Load Chart of FJ

> 13

Working range of H

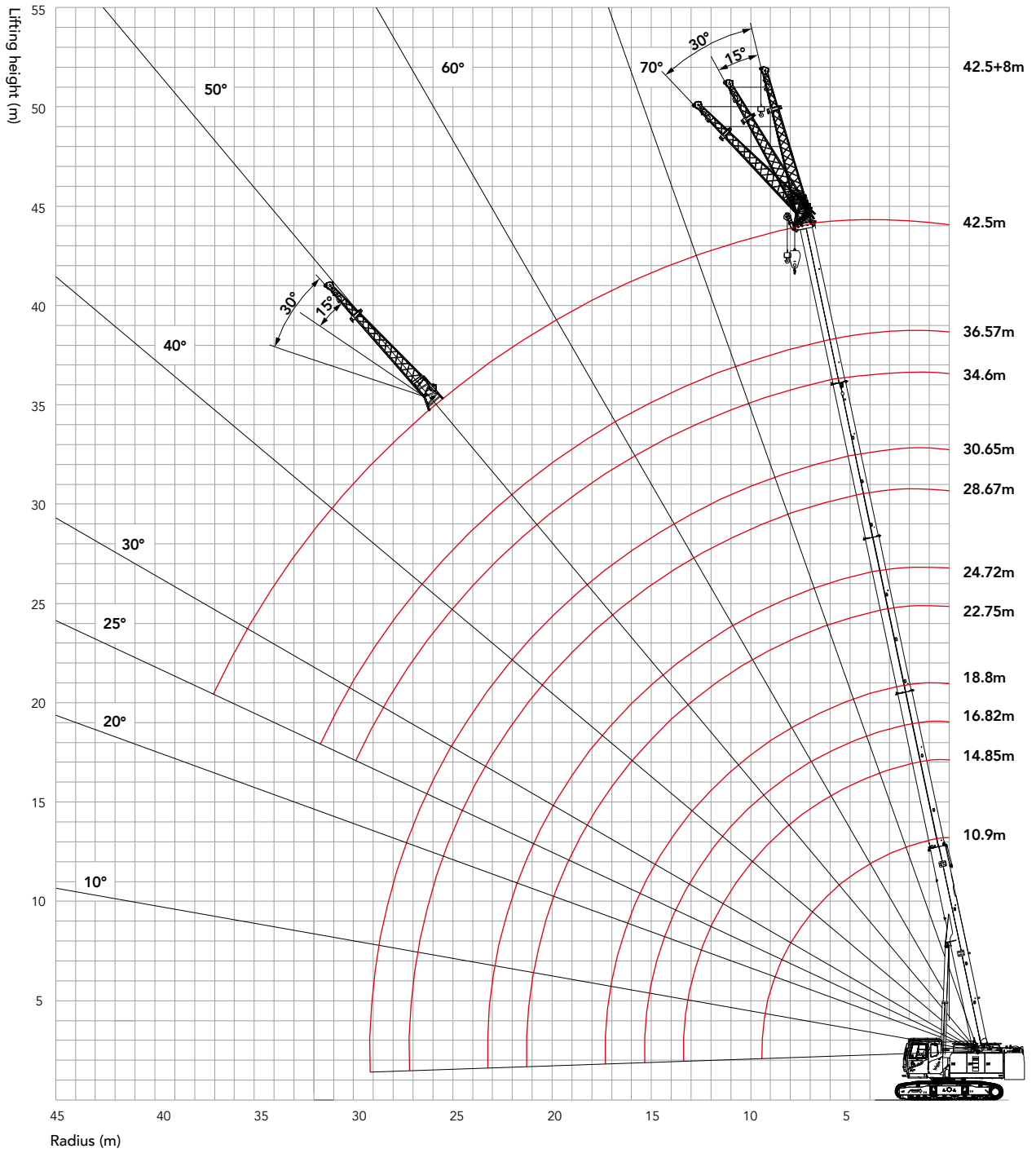

Unit: t

Load Chart of H

H Configuration																
Counterweight 11t (ground slope 0~1°)																
Radius (m)	10.9	14.85	16.82	18.8	20.77	22.75	24.72	26.7	28.67	30.65	32.62	34.6	36.57	38.55	42.5	Radius (m)
3	30	28	26.3													3
3.5	30	27	24.2													3.5
4	28	26	22.5	24.4	22.2	18	18.9									4
4.5	26	25	20.9	22.7	20.7	18	18.6	15.5								4.5
5	25	23.7	19.5	21.2	19.3	18	18.6	15.5								5
5.5	22	21	18.3	19.1	18.1	18	18.6	15.5	11.2							5.5
6	20.3	18.5	17.2	18.2	17	16.4	17.5	15	10.5	13.5						6
6.5	18	17	16.3	15.3	15.9	14.9	16	11.7	10.2	13.5	11.5	8.5	9.6			6.5
7	15.6	15	15.4	13.8	14.5	13.6	14.8	14.5	10	13.5	11.5	8.3	9.6			7
7.5	14	13.6	14.4	12.6	13.3	12.5	12.5	13.1	9.5	12.5	11	8.2	9.6			7.5
8	12.4	12.2	13.3	12	12.4	12.8	12	12.1	9.4	12	10.5	8	9.6	6.6		8
9	10.2	9.9	11.1	9.6	10.4	10.8	10	9.3	8.7	9.8	9.6	7.5	9.1	6.6	6.8	9
10		8.2	9.3	8.1	9	9	8.8	9	8.5	8.5	9.1	7	8.7	6.4	6.7	10
11		6.9	8	6.8	7.6	7.6	7.5	7.8	7.6	8.5	7.8	6.5	8.2	6.2	6.5	11
12		5.8	6.9	5.7	6.6	6.6	6.3	6.8	7	6.8	7.5	6	7.6	6	6.3	12
13		4.9	6	4.8	6.1	6.1	5.5	6	6.5	5.6	6	5.6	6.6	5.8	6	13
14			5.2	4.1	5.6	5.4	4.7	5.2	6	5	5.5	5.2	5.7	5.5	5.6	14
15			4.6	3.5	5	4.8	4.1	4.5	5.5	4.4	5	4.8	5	4.8	5	15
16				2.9	4.4	4.3	3.6	4.1	4.9	4	4.5	4.6	4.4	4.5	4.5	16
17				2.5	3.9	3.4	3.1	3.5	4.4	3.5	4	4.2	3.6	4	4	17
18					3.5	3.2	2.7	3.1	3.9	3	3.5	4	3.3	3.6	3.6	18
19					3.2	2.9	2.3	2.8	3.5	2.7	3.1	3.5	3	3.2	3.2	19
20					2.8	2.6	2	2.5	3.2	2.4	2.8	3	2.7	3	2.9	20
22							1.4	1.9	2.7	1.8	2.5	2.6	1.9	2.5	2.5	22
24								1.5	1.9	1.4	2	2.2	1.5	2	1.8	24
26									1.6	1	1.5	1.7	1.1	1.8	1.5	26
28										0.7	1	1.5	1	1.1	1.2	28
30											0.7	1.2	0.8	0.9	0.8	30
Min. protection angle(°)															25	Min. protection angle(°)
Boom 2	0	50	0	100	50	0	100	50	0	100	50	0	100	50	100	Boom 2
Boom 3	0	0	25	0	25	50	25	50	75	50	75	100	75	100	100	Boom 3
Boom 4	0	0	25	0	25	50	25	50	75	50	75	100	75	100	100	Boom 4
Boom 5	0	0	25	0	25	50	25	50	75	50	75	100	75	100	100	Boom 5

Load Chart of H

H Configuration																
Counterweight 0t (level ground 0~1°)																
Radius (m)	10.9	14.85	16.82	18.8	20.77	22.75	24.72	26.7	28.67	30.65	32.62	34.6	36.57	38.55	42.5	Radius (m)
3	26	21	21													3
3.5	20.5	17.3	17.5													3.5
4	16.5	14.2	15	12.4	13	13.4	11.4									4
4.5	13.9	11.9	12.8	10.4	11.1	11.6	9.8	10.2								4.5
5	11.7	10.1	11	8.9	9.6	10.2	8.5	8.9	9.3							5
5.5	10.1	8.6	9.6	7.6	8.4	9	7.4	7.9	8.3	7						5.5
6	8.7	7.5	8.5	6.6	7.4	8	6.5	7	7.5	6.3	6.6					6
6.5	7.4	6.5	7.5	5.7	6.5	7.2	5.8	6.3	6.7	5.6	6	6.1	5.3			6.5
7	6.3	5.7	6.7	5	5.8	6.5	5.1	5.6	6.1	5	5.4	5.7	4.8	5.1		7
7.5	5.5	5	6	4.3	5.2	5.8	4.5	5.1	5.5	4.5	4.9	5.2	4.3	4.7		7.5
8	4.7	4.4	5.4	3.8	4.6	5.3	4	4.6	5.1	4	4.4	4.8	3.9	4.2	3.8	8
9	3.5	3.3	4.4	2.8	3.7	4.4	3.2	3.7	4.2	3.2	3.7	4.1	3.2	3.6	3.1	9
10		2.5	3.5	2.1	3	3.7	2.5	3.1	3.6	2.6	3.1	3.4	2.6	3	2.6	10
11		1.8	2.8	1.5	2.4	3.1	1.9	2.5	3	2.1	2.5	2.9	2.1	2.5	2.1	11
12		1.2	2.2	1	1.9	2.6	1.5	2.1	2.6	1.7	2.1	2.5	1.7	2.1	1.8	12
13		0.8	1.8	0.6	1.4	2.1	1.1	1.7	2.2	1.3	1.7	2.1	1.4	1.7	1.4	13
14			1.4	0.3	1.1	1.7	0.7	1.3	1.8	1	1.4	1.8	1.1	1.4	1.1	14
15			1.1		0.8	1.4	0.4	1	1.5	0.7	1.1	1.5	0.8	1.2	0.9	15
16					0.5	1.1		0.8	1.3	0.4	0.9	1.3	0.6	0.9	0.6	16
17					0.3	0.9		0.5	1		0.7	1.1	0.4	0.7	0.4	17
18						0.7		0.3	0.8		0.5	0.9		0.5	0.3	18
Min. protection angle(°)				29	20		40	33	23	46	42	36	50	49	55	Min. protection angle(°)
Boom 2	0	50	0	100	50	0	100	50	0	100	50	0	100	50	100	Boom 2
Boom 3	0	0	25	0	25	50	25	50	75	50	75	100	75	100	100	Boom 3
Boom 4	0	0	25	0	25	50	25	50	75	50	75	100	75	100	100	Boom 4
Boom 5	0	0	25	0	25	50	25	50	75	50	75	100	75	100	100	Boom 5

Unit: t

Load Chart of FJ

FJ Configuration				
Working angle	Counterweight 11t (level ground 0~1°)			Working angle
	42.5m+8m			
	Installation of jib angle			
	0°	15°	30°	
78°	2.4	2.1	1.5	78°
75°	2.4	2	1.35	75°
72°	2.3	1.8	1.3	72°
70°	2.2	1.6	1.2	70°
65°	1.6	1.3	0.9	65°
60°	1.1	1	0.6	60°
55°	0.6	0.3	0.3	55°
Min. operation angle	55°			Min. operation angle

Note-Rate load of crane:

- ① . The rated load chart should be divided into load chart of level ground/ground slope according to ground situation. Auto-switch mode has been used since it was done, which means load chart can be switched by hand.
- ② . Level ground should be steady ground within 1°. Ground slope should be steady ground within 4°.
- ③ . The rated capacity in the load charts are calculated when the crane is parking on the firm ground, and lifting the load slowly and steadily.
- ④ . The rated capacity values in the load charts are obtained when the wind speed is lower than 9.8 m/s under 75% of tipping load.
- ⑤ . The gray-shaded values in boom load chart are determined by boom strength, and the rest of values are determined by stability; the values in FJ load chart are determined by boom strength.
- ⑥ . All values in the load charts are valid for 360° slewing.
- ⑦ . The rated load shall be no more than 4.1t when using upper boom point sheave. If the jib unfolds, the rated lifting capacity of boom shall be 0.5t less.
- ⑧ . The rated capacity in the load charts includes the weight of lifting hook(main hook 0.32t, jib hook 0.09t). Therefore, the actual rated capacity is the value after deducing the weight of lifting tools(such as hook, riggings and wire rope) from the rated load in the load charts.
- ⑨ . If the actual boom /jib length and angle falls between 2 length given in the table, the larger one shall be taken to refer to the lifting capacity.



Zhejiang Sany Equipment Co.,LTD

SANY Crawler Crane Industrial Park, No. 2188 Daishan Road, Wuxing District, Huzhou City,
Zhejiang Province, P. R. China Zip 313028
Consulting sanycrane@sanygroup.com (Crane BU) / crd@sany.com.cn (IHQ)
After-sales Service 0086-400 6098 318

Reminder:

Any change in the technical parameters and configuration due to product modification or upgrade may occur without prior notice.
The machine in the picture may include additional equipment. This brochure is for reference only, and goods in kind shall prevail.
Copyright at SANY. No part of this brochure may be copied or used for any purpose without written approval from SANY.

© Edited in April 2023

