

SCA900TB

Telescopic Boom Crawler Crane

Quality Changes the World



Max. Lifting Capacity: 90 USt
Max. Boom Length: 154.2 ft
Max. Boom + Jib Length: 154.2 + 57.4 ft

■ www.sanyamerica.com



Telescopic Boom Crawler Crane SCA900TB

P03

Main Features

- Driver's Cab
- Upperworks
- Lowerworks
- Counterweight
- Hydraulic System
- Operating Weight
- Ground Pressure
- Gradeability
- Operating Equipment
- Safety Devices

P10

Technical Parameters

- Main Performance Parameters
- Dimensions
- Transport Dimensions
- Transport Plan

P20

Boom and Jib Combinations

- (H) Main Boom Operating Conditions
- (F.J) Fly Jib Operating Conditions



**SCA900TB
TELESCOPIC BOOM CRAWLER CRANE
90 UST (81.6 TONS) LIFTING CAPACITY**

Main Features

- Page 04 Driver's Cab
- Page 04 Upperworks
- Page 05 Lowerworks
- Page 06 Counterweight
- Page 06 Hydraulic System
- Page 06 Operating Weight
- Page 06 Ground Pressure
- Page 06 Gradeability
- Page 07 Operating Equipment
- Page 08 Safety Devices



Driver's cab



Exterior

- The cab's industrial design features classic outline and strength. Hinged door structure is adopted, that is perfectly suitable on the crawler crane for the operator to get in and out. Fully-enclosed steel frame is applied with large faces of high-strength tempered glass on front, side and top ceiling, admitting sufficient lights. Furthermore, the cab is capacious and bright, offering wider view for the operator.

Comfortability

- Multimode and multilevel adjustable mechanical suspension seat is mounted, providing the most comfortable driving experience for the operator. Denso air conditioning with multiple vents is provided to adjust the indoor temperature to a perfect level, dropping from 131°F (55°C) to 81.5°F (27.5°C) within 20 minutes. The seat, handles and buttons on right and left armrests are laid out ergonomically with full consideration given to the operator's needs and habits. The control box and the seat can be adjusted together or separately to the most comfortable position for the operator to make operation at ease. The 10.4-inch LMI touch screen features programmable switch keys and perfect UI design and also functions real-time monitoring images display including winch wire rope reeving, circumstances behind the counterweight and around the crane. The vibration handle can be offered optionally. The driver's cab can tilt 0~20° as needed for the work.

Upperworks



Engine

- Cummins L9-C325, Stage V
- Rated power: 325 HP;
- Rated speed: 1,800 rpm;
- Max. output torque: 1,126 ft-lb;
- Speed at maximum output torque: 1,500 rpm.

Main/Aux. Load Hoist Mechanism

- Pump and motor: dual variable displacement with speed adjustable, to achieve higher winch speed and lower down energy consumption. Winch balance valve combined with anti-hook sliding technology can ensure stable lifting operation.
- Winch brake adopts wet type and spring loaded fin type normally engaged brake, spring force braking, oil pressure released.
- Main and aux. load hoist systems adopt piston motor of variable displacement to drive planetary gearbox.

Main Load Hoist Winch	Rope speed on the outermost layer	0~459.3ft/min (0-140m/min)
	Wire rope diameter	0.87" (Φ22mm)
	Wire rope length	803'9" (245m)
	Rated single line pull	17.6Klb (8.0t)
Axu. Load Hoist Winch	Rope speed on the outermost layer	0~459.3ft/min (0-140m/min)
	Wire rope diameter	0.87" (Φ22mm)
	Wire rope length	475'8" (145m)
	Rated single line pull	17.6Klb (8.0t)

Upperworks



Boom Luffing Mechanism

- Dual-acting single piston hydraulic cylinder, with safety balance valve, and a luffing angle of $-1.5^{\circ} \sim 80^{\circ}$. Luffing down through self-weight to reduce energy consumption and increase stability of luffing down operation.

Slewing Mechanism

- Slewing drive: external gear slewing drive enables 360° rotation, and the max. slewing speed is $2r/min$. The max. drive pressure can reach 20MPa.
- Slewing brake adopts wet, spring loaded, normally-closed brake, and braking through spring force. Unique slewing buffer design ensure steady brake, free of starting and stopping impact.
- Slewing system, equipped with integrated slewing buffer valve, has free slipping function. It is featured in steady start and stop, control and excellent inching performance.
- Slewing lock: cylinder lock device can make sure the upperworks locked on four directions when the crane is not in service or during transport, which is more safer and reliable.
- Slewing bearing: single-row roller ball bearing.

Lowerworks



Car-body

- The hydraulic cylinder drives power pin to be connected with track frame to facilitate the assembly and disassembly. Frame structures are welded by high-strength steel. Larger chassis design greatly improves the stability of the crane.

Side Frame

- Track frame: each track frame is equipped with an independent travel driving device. A hydraulic travel motor drives the planetary gear reducer and realizes independent traveling through the transmission of driving wheel. The travel speed is controlled by variable displacement of the motor. Infinite variable speed can be realized in travel driving system.
- Track shoe: it is manufactured by advanced casting techniques and materials with high strength and good wear resistance. After assembled on the machine, the tension can be adjusted by a hydraulic jack with shims used to secure the crawler position.

Counterweight



- Include Carbody Counterweight, Rear Counterweight

Name	Quantity	Length	Width	Height	Unit Weight
Carbody Counterweight	2	5'3" (1.6m)	2'11" (0.9m)	2'4" (0.72m)	6.6 Klb (3t)
Counterweight Tray	1	11'4" (3.45m)	3'12" (1.21m)	4'5" (1.369m)	36.4 Klb (16.5t)
Rear Counterweight I	2	2'4" (0.7m)	3'7" (1.1m)	2'8" (0.82m)	5.3 Klb (2.4t)
Rear Counterweight II	2	2'4" (0.7m)	3'8" (1.11m)	2'7" (0.8m)	5.3 Klb (2.4t)

Hydraulic System



- Main pumps: Open variable displacement piston pumps of large displacement is adopted to provide oil supply for main actuators of main machine.
- Gear pump: Dual gear pump for slewing, radiator and control circuit.
- Control: Main pump adopts electrically-controlled positive flow control; winch motor adopts limitless adjustable piston motor of variable displacement. The operating components are two cross hydraulic handle, one hydraulic pedal for boom telescoping, one dual travel pedal control valve to control various actuator proportionally.
- Cooling system: Multi-stage cooling including heat exchanger and fan.
- Filter: Large flow high precision filter, with bypass valve and transmitter, which can remind the user to replace the filter element in time.
- Max. pressure of hydraulic system:
Main/aux. load hoist and travel system: 32 Mpa;
Boom hoist cylinder: 32 Mpa;
Slewing system: 20 MPa;
Control system: 5 MPa.
- Hydraulic Tank Capacity: 251Gal (950L).

Operating Weight



- The operating weight is about 194.4Klb (88.2t), including the upperworks, lowerworks, rear counterweight of basic machine, center counterweight, 40 ft-154.2 ft (12.2m-47m) boom and 2.9Klb (1.31t) hook.

Ground Pressure



- The average ground pressure of machine with basic boom is 0.9 kgf/cm² (13.05psi).

Gradeability



- The gradeability of the track base boom machine with basic boom is 30%.

Operating Equipment



All operating equipment adopt high-strength steel pipe, so do the steel plates. The sheaves used on boom/jib top and hooks are all rolled material and welded structure.

Boom

- The boom is made of high-strength steel structure with U-shape section area, with five sections. Fully retracted length is 40' (12.2m) and the max. length is 154'2" (47m).
- Dual cylinder full power rope pull telescoping.

Fly Jib

- Two-stage fly jib, 33'6" (10.2m) and 57'5" (17.5m), offsetable at 0°, 15°, 30°.

Boom Point Sheave Block

- Weld structures, connected to the boom through pins and used for hook ball.

Hook Block

- There are five hook capacity for options:

Hook Type	Rated Capacity	No. of sheaves	Unit weight
Hook block	90USt (80Mt) (optional)	5	2.3Klb (1.05t)
Hook block	50USt (45Mt)	3	1.1Klb (0.48t)
Hook block	16USt (15Mt) (optional)	1	0.28Klb (0.34t)
Hook block	10USt (9Mt)	None	0.6Klb (0.26t)

Note: the above-mentioned operating equipment is full-up configuration. The actual configurations are subject to contract.

Hook Height

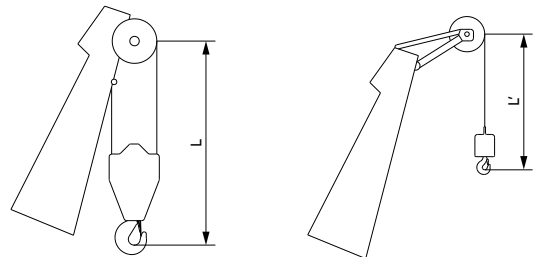

Hook	L	Hook	L'
90UST (80t) (optional)	11.5ft (3.5m)	10UST (9t)	9.8ft (3m)

Safety Devices



Integrated LMI Control System

- LMI control system is standard offering and it is calibration-free. It ensures the operation safety and improves efficiency;
- LMI system can automatically detect the load weight, working radius and boom angle, to compare with rated load weight and actual load, work radius and boom angle. In normal operation, it can make judgment and cut off the actions towards dangerous directions. It also acts as black box to record overload information;
- Composition: monitor, controller, length and angle sensor, pressure sensor.

Assembly/Work Mode Control Switch

- In Assembly Mode, the over-hoist protection, LML are all off work to facilitate crane assembly;
- In Work Mode, all safety devices activate to protect the operation.

Emergent Stop

- In emergent situation, this button is pressed down to cut off the power supply of whole machine and all actions stop.

Over-hoist Protection of the Main/Auxiliary Hooks

- Height limit device is installed at the tip of main boom and jib, which prevents the hook lift up too much. When the hook lifts up to the limit height, the limit switch activates, buzzer on the left control panel sends alarm, and failure indicator light starts to flash, the hook hoisting action is cut off automatically.

Over-release Protection Device of the Main/Auxiliary Winch

- Three-wrap protector is installed on main and aux. load hoist winches to prevent over-release of wire rope. When the rope is paid out close to the last three wraps, the limit switch acts, and the system sends alarm through buzzer and show the alarm on the instrument panel, automatically cutting off the winch action.

Function Lock

- If the function lock level is not in work position, all the other handles won't work, which prevents any mis-operation caused by accidental collision.

Swing Lock

- Electrical lock is equipped, and swing action can only happen when the lock is released, so as to prevent any operational error and ensure the safety;
- The cylinder lock can lock the upperworks at four directions.

Safety Devices



Hook Latch

- The lifting hook is installed with a baffle plate to prevent wire rope from falling off.

Monitoring System

- Remote Monitoring system is a standardized offering to provide functions like GPS locating, GPRS data transfer, machine status inquiry and statistics, operating data monitoring and analysis, remote diagnosis of failures.

Tri-color Load Indicator

- The load indication light has three colors, green, yellow and red, indicating the real-time load. When the actual load is smaller than 90% of rated load, the green light is on;
- When the actual load is $>90\%$ and $\leq 100\%$, the yellow light is on, the alarm light flashes and sends out intermittent sirens;
- When the actual load reaches 100% of rated load, the red light on, the alarm light flashes and sends out continuous sirens;
- When the actual load is 102% of rated load, the system will automatically cut off the crane's dangerous operation.

Flash Alarm

- When the LMI system is powered on, the flash alarm starts to flash.

Swing Indicator Light

- The swing indicator light flashes during traveling or swing.

Seat Interlock Protection

- If the operator leaves the seat, all control handles will be locked immediately to prevent any mis-operation due to accidental collision.

Illuminating Light

- The machine is equipped with, low-beam light in front of machine, lamps in operator's cab and boom lights, so as to increase the visibility during work.

Rearview Mirror

- It is installed on the front of the operator's cab and the handrail of the right platform and the winch.

Electronic Level Gauge

- It can show the upperworks tipping angle on the monitor.

Monitor System (zoom camera)

- Two cameras and illumination lights are installed on the tail of rotating bed, which will show the conditions on the rear and winches on the monitor. The camera can zoom in/out as needed.
- Components: Wireless remote transmitter, wireless remote receiver, zoom camera.



SCA900TB
TELESCOPIC BOOM CRAWLER CRANE
90 UST (81.6 TONS) LIFTING CAPACITY

Technical Parameters

- Page 11 Main Performance Parameters
- Page 12 Dimensions
- Page 13 Transportat Dimensions
- Page 16 Transport Plan



Main Performance Parameters

Main Performance Parameters of SCA900TB			
Performance indicators		Unit	Parameter
Outline dimension	Machine length	ft (mm)	47.77 (14560)
	Machine width	ft (mm)	16.73 (5100) (Extended) 11.45 (3490) (Retracted)
	Machine height	ft (mm)	12.0 (3670)
	Distance of centers between drive and idle wheels	ft (mm)	17.8 (5436)
	Track shoe width	ft (mm)	2.8 (850)
H Configuration	Max. rated lifting capacity	UST (t)	90 (81.6)
	Boom length	ft (m)	40~154.2 (12.2~47)
	Boom angle	°	-1.5~80
	Max. rated lifting moment	Klb-ft (t-m)	2170 (300)
FJ Configuration	Longest boom + longest jib	ft (m)	154.2+57.4 (47+17.5)
	Boom to jib angle	°	0、15、30
Operation speed	Speed of single rope of the main/aux. hoist (outermost work layer)	ft/min (m/min)	0-459.4 (0~140)
	Boom full luffing up/down duration	s	80/105
	Boom full extension/retraction duration	s	100/125
	Swing speed	rpm	0~2
	Travel without load	mph (km/h)	1.55 (0~2.5)
Engine	Engine		L9-C325 242kW stage V
	Output power	kW/rpm	242/1800
Wire rope	Diameter	in (mm)	0.87 (Φ22)
Transport parameter	Machine weight	Klb (t)	194.4 (88.2)
	Weight of largest single piece	Klb (t)	78.7 (35.7)
	Transport dimensions of basic crane (dismantling crawler frame) length×width×height	ft (mm)	48.1×9.8×10.2 (14560×3000×3100)
Other parameters	Average ground bearing pressure (base boom)	MPa	0.09
	Min. swing radius	ft (mm)	14.8 (4500)

Dimensions

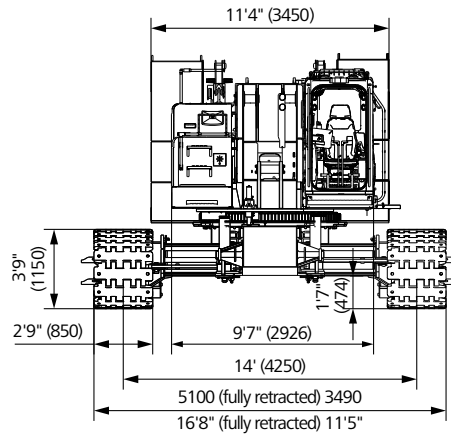
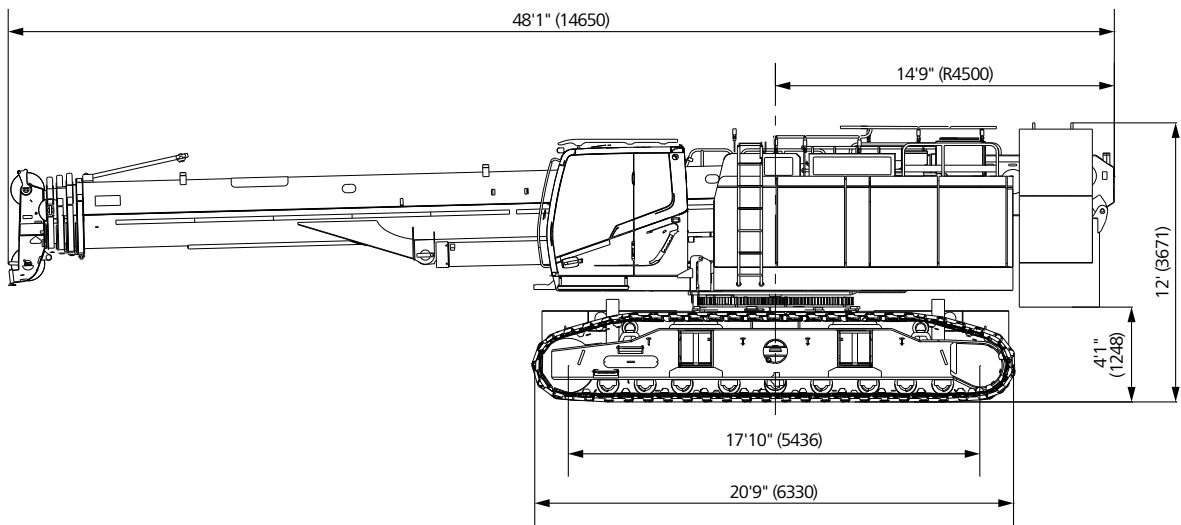

Transport Dimension

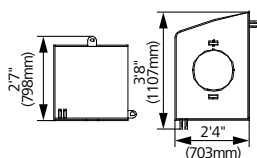
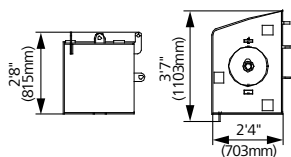
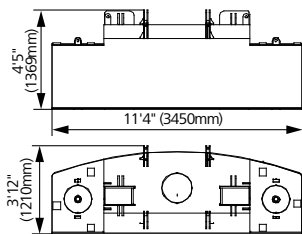
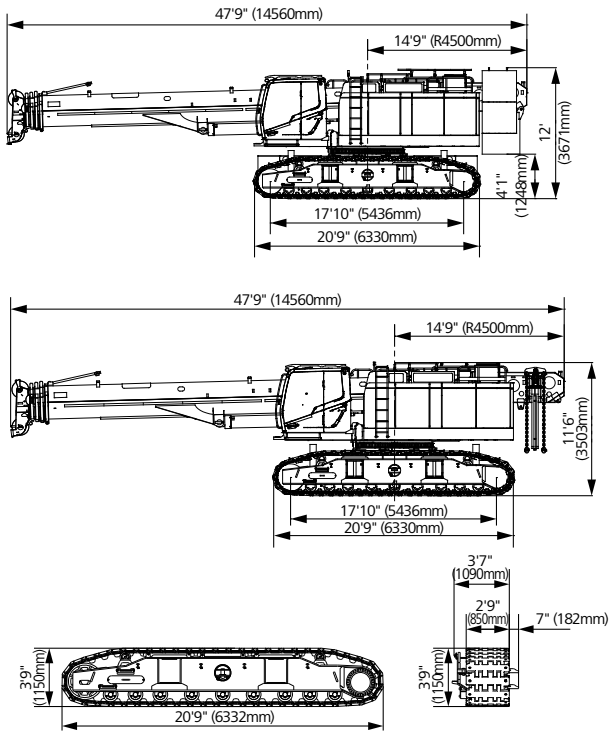

Full-rigged Machine

×1

Length (L)	47.8ft (14.56m)
Width (W)	11.5ft (3.49m)
Height (H)	12ft (3.67m)
Weight	194.4Klb (88.2t)

Basic Machine (with jib)

×1

Length (L)	47.8ft (14.56m)
Width (W)	11.5ft (3.49m)
Height (H)	11.5ft (3.50m)
Weight	121Klb (54.9t)

Side Frame

×2

Length (L)	20.8ft (6.33m)
Width (W)	3.6ft (1.09m)
Height (H)	3.8ft (1.15m)
Weight	21.2Klb (9.6t)

Counterweight Tray

×1

Length (L)	11.3ft (3.45m)
Width (W)	3.97ft (1.21m)
Height (H)	4.49ft (1.37m)
Weight	36.4Klb (16.5t)

Rear Counterweight I

×2

Length (L)	2.3ft (0.70m)
Width (W)	3.6ft (1.10m)
Height (H)	2.7ft (0.82m)
Weight	5.3Klb (2.4t)

Rear Counterweight II

×2

Length (L)	2.3ft (0.70m)
Width (W)	3.64ft (1.11m)
Height (H)	2.62ft (0.80m)
Weight	5.3Klb (2.4t)

Transport Dimension

Remarks:

- ① . The transport dimensions of each part in the table are schematic, not proportional to the real parts. The dimensions are designed value without packing.
- ② . The Weight is designed value that the actual manufactured part may deviate a little. The total weight of counterweight is 57.3Klb(26t).
- ③ . The above dimensions and weight is subject to change due to product upgrading.

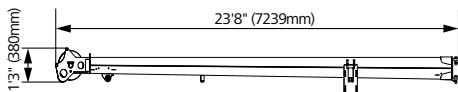
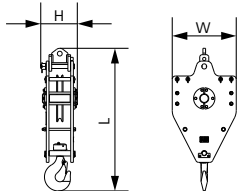
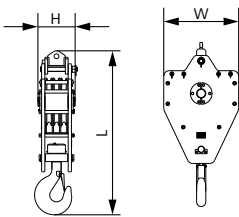
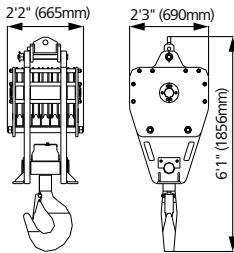
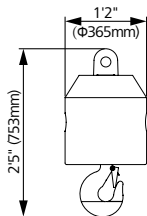
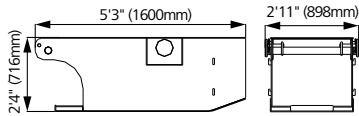

Carbody Counterweight ×2

Length (L)	6.6ft (1.60m)
Width (W)	3.0ft (0.90m)
Height (H)	2.4ft (0.72m)
Weight	6.6Klb (3.0t)

10 USt (9Mt) Hook Block ×1

Length (L)	2.5ft (0.75m)
Width (W)	1.2ft (0.37m)
Height (H)	1.2ft (0.37m)
Weight	0.41Klb (0.19t)

90 USt (80Mt)(optional) Hook ×1

Length (L)	6.1ft (1.86m)
Width (W)	2.3ft (0.69m)
Height (H)	2.2ft (0.66m)
Weight	2.2Klb (1.0t)

50 USt (45Mt) Hook ×1

Length (L)	5.0ft (1.52m)
Width (W)	2.3ft (0.69m)
Height (H)	1.2ft (0.37m)
Weight	1.1Klb (0.48t)

16 USt (15Mt) Hook (optional) ×1

Length (L)	4.4ft (1.34m)
Width (W)	1.9ft (0.60m)
Height (H)	1.1ft (0.34m)
Weight	0.61Klb (0.28t)

23.0 ft (7m) Swing-away ×1

Length (L)	23.8ft (7.24m)
Width (W)	1.2ft (0.38m)
Height (H)	1.7ft (0.51m)
Weight	0.57Klb (0.26t)

Transport Dimension

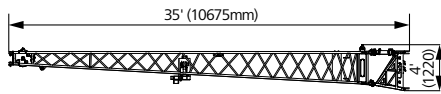

32.8 ft (10m) Jib Section

x1

Length (L)	35.0ft (10.68m)
Width (W)	2.5ft (0.76m)
Height (H)	4.0ft (1.22m)
Weight	1.5Klb (0.69t)

Transport Plan

■ Transport Dimensions:

Basic Machine (with main & aux. winches, boom, wire rope and aux. lifting sheave): 78.93 Klb (35800kg)

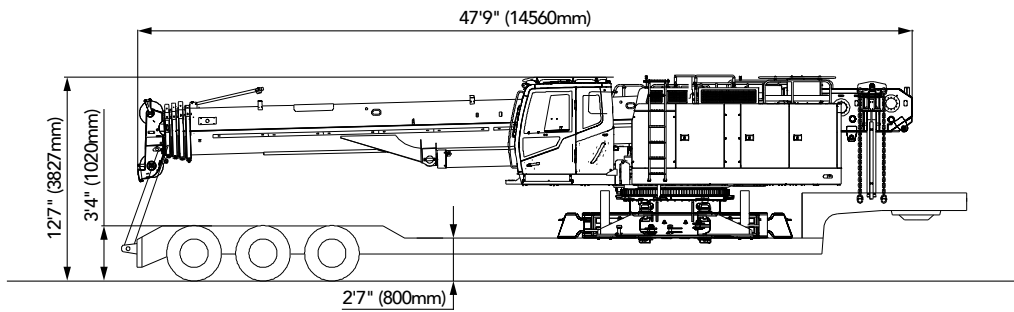

Item	Weight		Dimension (L×W×H)	Trailer			
	lbs	kg		1	2	3	4
Basic Machine (with 2 winches, boom, wire rope, Aux. lifting sheave)	78925	35800	47'9" × 11'6" × 11'6"	×			
Left Side Frame	21164	9600	20'9" × 3'7" × 3'9"		×		
Right Side Frame	21164	9600	20'9" × 3'7" × 3'9"		×		
Counterweight Tray	36376	16500	11'3" × 3'11" × 4'5"			×	
Rear Counterweight A - 1 Piece	5291	2400	2'3" × 3'7" × 2'8"				×
Rear Counterweight A - 1 Piece	5291	2400	2'3" × 3'7" × 2'8"				×
Rear Counterweight B - 1 Piece	5291	2400	2'3" × 3'7" × 2'7"				×
Rear Counterweight B - 1 Piece	5291	2400	2'3" × 3'7" × 2'7"				×
Front Carbody Counterweight	6614	3000	6'7" × 3' × 2'4"				×
Rear Carbody Counterweight	6614	3000	6'7" × 3' × 2'4"				×
Jib Top	573	260	23'9" × 1'2" × 1'8"			×	
Jib Base	1521	690	35' × 2'6" × 4'			×	
Hook Block - 90 Ust	2205	1000	6'1" × 2'3" × 2'2"		×		
Hook Ball - 10 Ust	419	190	2'6" × 1'2" × 1'2"		×		
Total Net Weight On Trailer	196741	89240		78925	44952	38471	34392

Transport Plan

Left Side Frame + Right Side Frame + 90 USt Hook Block + 10 USt Hook Ball: 44.95 Klb (20390kg)

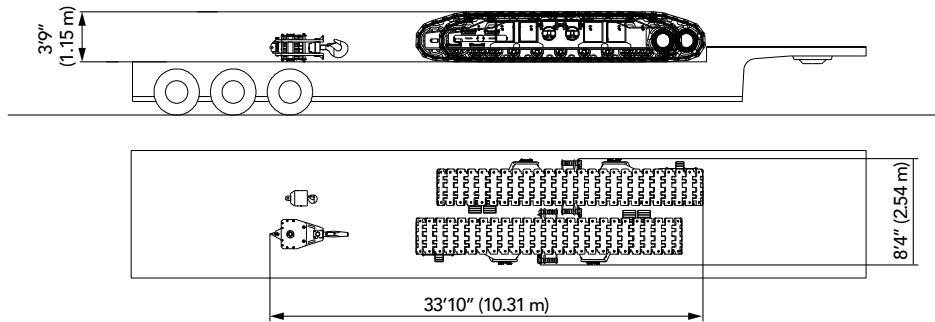

Rear Counterweight A × 2 + Rear Counterweight B × 2 + Front Carbody Counterweight + Rear Carbody Counterweight: 34.39 Klb (15600kg)

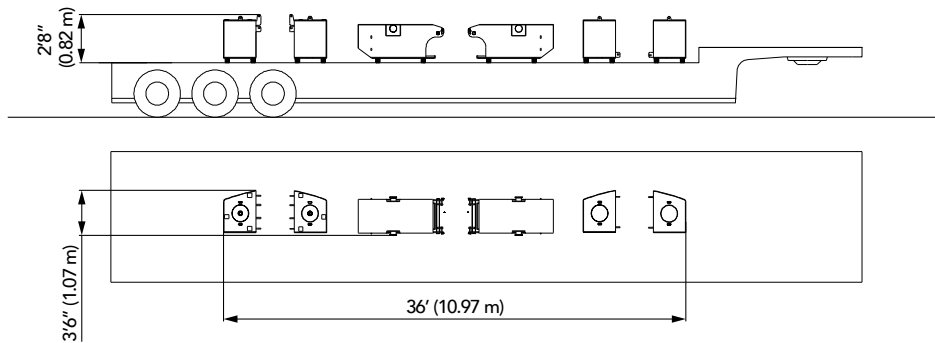

Counterweight Tray + Jib Tip + Jib Base: 38.47 Klb (14750kg)

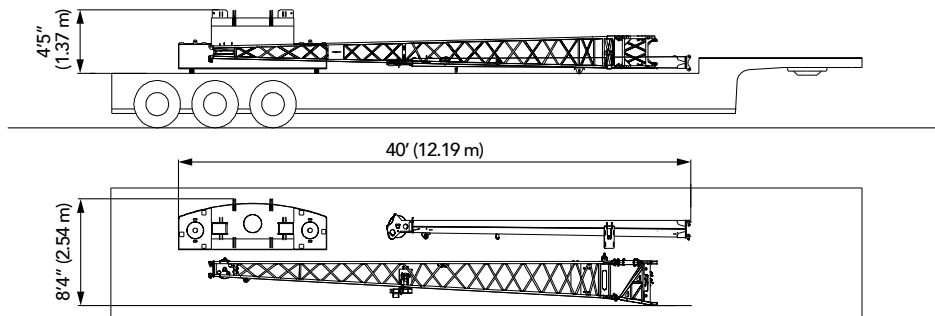

Transport Plan

■ Transport Dimensions:

Basic Machine (with main & aux. winches, boom, side frames, wire rope and aux. lifting sheave): 121.03 Klb (54900kg)

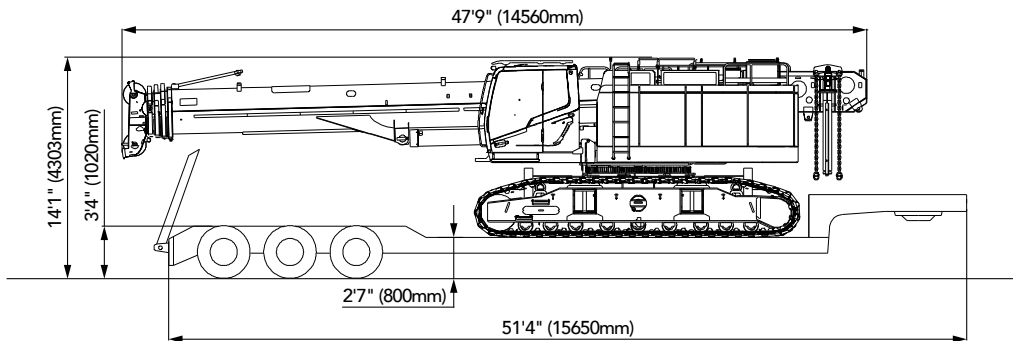

Item	Weight		Dimension (LxWxH)	Trailer		
	lbs	kg		1	2	3
Basic Machine (with 2 winches, boom, Side Frames, wire rope, Aux. lifting sheave)	121034	54900	47'9" x 11'6" x 12'	×		
Counterweight Tray	36376	16500	11'3" x 3'11" x 4'5"		×	
Rear Counterweight A - 1 Piece	5291	2400	2'3" x 3'7" x 2'8"			×
Rear Counterweight A - 1 Piece	5291	2400	2'3" x 3'7" x 2'8"			×
Rear Counterweight B - 1 Piece	5291	2400	2'3" x 3'7" x 2'7"			×
Rear Counterweight B - 1 Piece	5291	2400	2'3" x 3'7" x 2'7"			×
Front Carbody Counterweight	6614	3000	6'7" x 3' x 2'4"			×
Rear Carbody Counterweight	6614	3000	6'7" x 3' x 2'4"			×
Jib Top	573	260	23'9" x 1'2" x 1'8"		×	
Jib Base	1521	690	35' x 2'6" x 4'		×	
Hook Block - 90 USt	2205	1000	6'1" x 2'3" x 2'2"			×
Hook Ball - 10 USt	419	190	2'6" x 1'2" x 1'2"			×
Total Net Weight On Trailer	196520	89140		121034	38471	37016

Transport Plan

Rear Counterweight A × 2 + Rear Counterweight B × 2 + Front Carbody Counterweight
+ Rear Carbody Counterweight + 90 USt Hook Block + 10 USt Hook Ball: 37.02 Klb (16790kg)

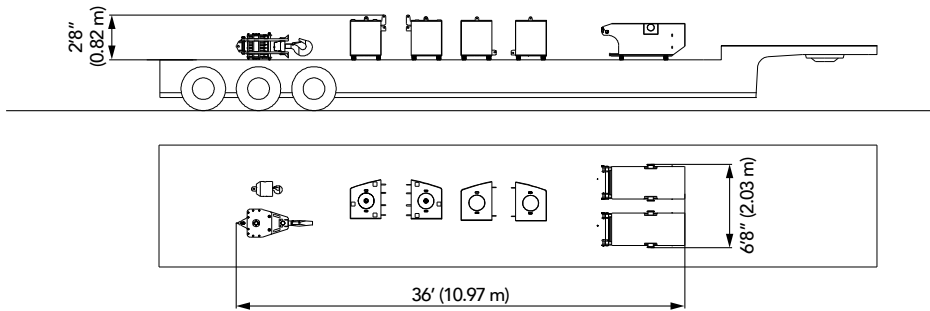

Counterweight Tray + Jib Tip + Jib Base: 38.48 Klb (14750kg)

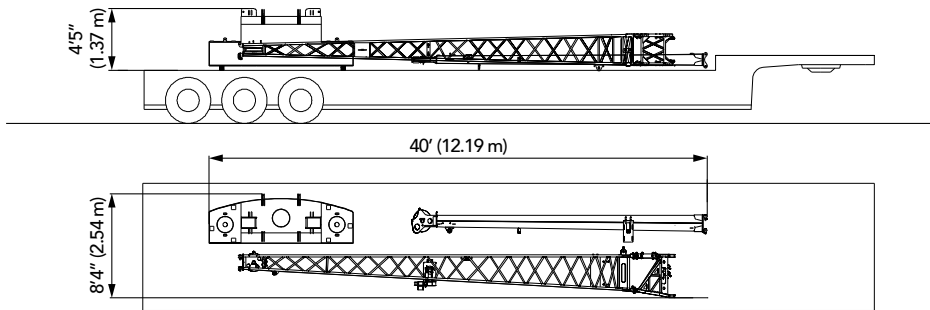



SCA900TB
TELESCOPIC BOOM CRAWLER CRANE
90 UST (81.6 TONS) LIFTING CAPACITY

Boom and Jib Combinations

- Page 22 (H) Main Boom Operating Conditions
- Page 26 (FJ) Fly Jib Operating Conditions

> 20



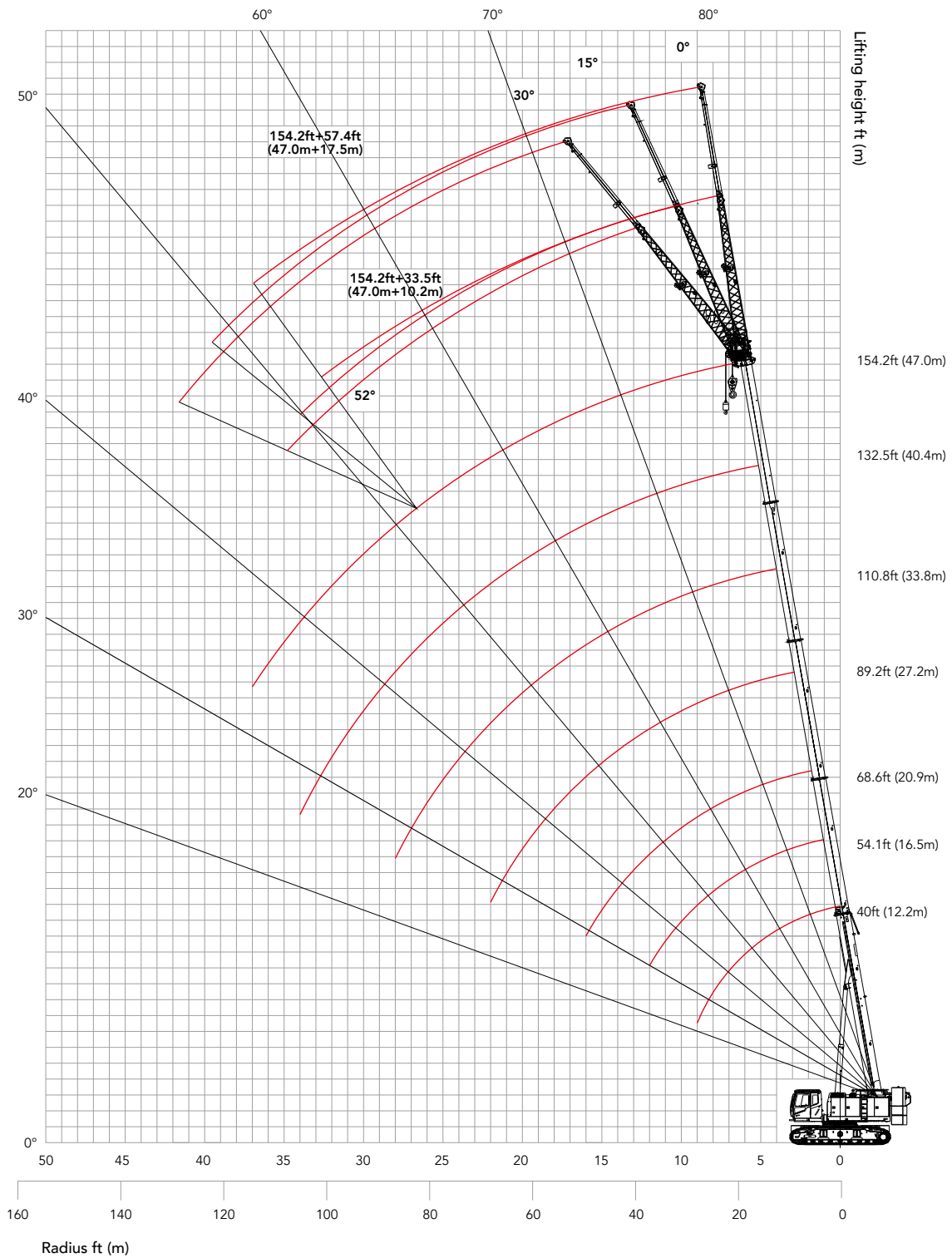



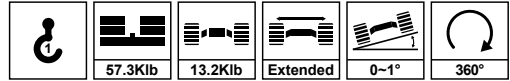

Working Range Diagram



(H) Main Boom Load Chart

Unit: Klb



 ft	Main Boom Length (ft)														 ft	
	40	54.1	61.4	68.6	75.5	82.7	89.2	96.8	104.3	110.9	118.1	125.7	132.5	139.4		154.2
10	180.0	142.9														10
12	160.5	137.9														12
14	146.4	133.8	66.2	95.8												14
16	131.7	124.8	66.2	94.0	66.2	60.1		60.1								16
18	119.3	110.5	66.2	87.5	66.2	57.4	66.2	57.4		55.2						18
20	109.1	101.9	63.9	85.0	63.9	54.9	65.7	54.9	43.9	52.5	43.9		43.7			20
25	79.4	78.9	61.7	68.1	62.6	50.8	58.9	51.5	39.2	47.9	40.5		38.4			25
30		57.3	58.2	56.6	58.3	47.0	52.7	48.2	35.0	44.9	36.7		35.1		25.7	30
35		44.7	46.1	43.4	45.8	43.5	44.3	44.7	31.6	38.2	32.8	23.5	31.2	24.0	24.2	35
40		35.7	37.0	33.5	36.2	38.3	37.7	36.8	28.8	32.5	29.6	22.4	27.4	23.1	23.3	40
45		27.0	29.6	26.8	29.5	31.3	30.6	30.1	26.1	28.3	27.0	21.4	26.0	22.6	22.6	45
50			25.2	21.7	24.1	26.1	25.1	25.2	24.1	25.0	25.0	20.1	23.5	21.9	21.8	50
55				17.6	19.9	22.1	20.6	21.2	21.9	21.5	22.3	18.7	21.1	20.8	20.0	55
60					16.8	19.0	17.1	17.8	19.4	18.0	19.1	17.4	19.1	19.2	17.6	60
65					14.6	16.6	14.4	15.5	16.8	15.5	16.4	16.2	16.4	16.8	16.2	65
70						14.8	12.3	13.3	14.6	13.4	14.3	14.8	14.3	14.9	14.4	70
75							10.3	11.4	12.6	11.5	12.5	13.3	12.4	13.2	12.9	75
80								9.9	10.9	9.8	10.9	12.0	10.6	11.6	11.6	80
85								9.1	9.8	8.5	9.6	10.4	9.1	10.2	10.2	85
90									9.2	7.3	8.4	9.3	7.9	9.0	9.0	90
95										6.1	7.3	8.3	6.9	8.0	8.1	95
100											6.4	7.4	5.9	7.0	7.2	100
105												6.6	5.1	6.3	6.2	105
110												6.1	4.2	5.4	5.5	110
115													3.5	4.6	4.6	115
120														4.0	3.6	120
125															2.8	125
130															2.3	130
135															1.8	135
140															1.3	140
144															0.9	144
 #	12	10	10	8	8	6	6	6	5	5	5	4	4	3	3	 #
 2#	0	50	0	100	50	0	100	50	0	100	50	0	100	50	100	2#
 3#	0	0	25	0	25	50	25	50	75	50	75	100	75	100	100	3#
 4#	0	0	25	0	25	50	25	50	75	50	75	100	75	100	100	4#
 5#	0	0	25	0	25	50	25	50	75	50	75	100	75	100	100	5#

(H) Main Boom Load Chart

Unit: Klb









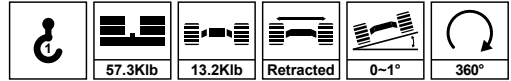



ft	Main Boom Length (ft)															ft	
	40	54.1	61.4	68.6	75.5	82.7	89.2	96.8	104.3	110.9	118.1	125.7	132.5	139.4	154.2		
10	142.4	117.9														10	
12	102.5	86.9														12	
14	80.1	69.5	65.1	61.5												14	
16	65.9	57.9	61.0	51.7	54.2	55.8										16	
18	50.4	45.5	48.8	41.0	43.5	45.4	39.2	40.8								18	
20	44.0	41.4	45.1	37.4	40.4	42.6	36.6	38.4	39.9	35.0	36.2					20	
25	27.1	26.4	30.7	24.8	27.9	30.8	25.3	27.3	29.9	24.9	27.3		23.9			25	
30		19.3	23.6	18.8	22.5	25.2	20.4	22.7	24.4	20.5	22.3		20.3		19.7	30	
35		13.7	17.6	13.2	16.5	19.2	15.6	17.9	19.8	16.1	17.8	19.3	16.2	17.5	15.9	35	
40			13.5	9.3	12.4	15.0	11.7	13.9	15.9	12.9	14.5	16.0	13.1	14.5	13.0	40	
45			10.5	6.3	9.6	12.0	8.7	10.9	12.9	10.2	11.9	13.5	10.6	11.9	10.8	45	
50					7.3	9.7	6.5	8.7	10.6	7.9	9.7	11.1	8.6	10.0	8.9	50	
55					5.3	7.8	4.7	6.9	8.6	6.1	7.8	9.2	7.0	8.3	7.3	55	
60						6.2	3.1	5.3	7.1	4.6	6.1	7.7	5.5	6.8	5.9	60	
65							5.0	1.9	3.9	5.9	3.2	4.8	6.3	4.1	5.5	65	
70									3.0	4.7	2.2	3.7	5.3	3.2	4.4	70	
75										3.8		2.9	4.4	2.4	3.5	75	
80										3.1		2.2	3.6		2.7	80	
85										2.3		1.4	2.9		2.0	85	
90													2.2		1.5	90	
95													1.7			95	
	12	10	10	8	8	6	6	6	6	5	5	5	4	4	3	3	
2#	0	50	0	100	50	0	100	50	0	100	50	0	100	50	100	100	2#
3#	0	0	25	0	25	50	25	50	75	50	75	100	75	100	100	100	3#
4#	0	0	25	0	25	50	25	50	75	50	75	100	75	100	100	100	4#
5#	0	0	25	0	25	50	25	50	75	50	75	100	75	100	100	100	5#

(H) Main Boom Load Chart

Unit: Klb



 ft	Main Boom Length (ft)															 ft
	40	54.1	61.4	68.6	75.5	82.7	89.2	96.8	104.3	110.9	118.1	125.7	132.5	139.4	154.2	
10	167.2	140.8														10
12	129.3	115.0														12
14	107.4	97.9	66.2	87.1												14
16	89.9	85.5	66.2	78.5												16
18	71.0	69.0	66.2	64.5	65.7	57.4										18
20	64.4	63.7	62.7	61.1	62.3	54.9	59.1	54.5								20
25	43.6	42.9	46.7	42.6	45.6	48.6	44.4	45.0	39.2	43.4						25
30		34.5	38.4	34.0	37.3	39.8	36.5	38.9	35.0	36.8	36.7		34.5			30
35		26.8	30.6	26.5	29.5	32.0	28.8	31.0	31.6	30.3	31.7	23.5	30.0	24.0		35
40			24.8	20.9	23.9	26.4	23.3	25.5	27.2	24.6	26.3	22.4	25.5	23.0	24.0	40
45			20.6	16.8	19.7	22.2	19.1	21.1	22.9	20.4	22.0	21.4	21.3	22.0	21.6	45
50				13.6	16.5	18.8	15.8	17.8	19.6	17.2	18.7	19.5	18.0	19.4	18.7	50
55					13.8	16.0	13.1	15.1	16.9	14.5	16.0	17.3	15.4	16.7	16.0	55
60						13.8	10.9	12.9	14.6	12.2	13.8	15.1	13.1	14.4	13.8	60
65							11.9	9.0	11.0	12.8	10.4	11.9	13.2	11.2	12.6	65
70								7.5	9.5	11.2	8.8	10.4	11.7	9.7	11.0	70
75									8.2	9.9	7.5	9.0	10.4	8.4	9.7	75
80										8.8	6.4	7.9	9.2	7.2	8.5	80
85										7.8	5.3	6.9	8.2	6.2	7.3	85
90											4.5	6.0	7.4	5.4	6.5	90
95												5.2	6.5	4.5	5.7	95
100													5.7	3.8	5.1	100
105														3.3	4.4	105
110														2.6	3.7	110
115															2.7	115
 C _n	12	10	10	8	8	6	6	6	5	5	5	4	4	3	3	 C _n
 2#	0	50	0	100	50	0	100	50	0	100	50	0	100	50	100	2#
 3#	0	0	25	0	25	50	25	50	75	50	75	100	75	100	100	 3#
 4#	0	0	25	0	25	50	25	50	75	50	75	100	75	100	100	 4#
 5#	0	0	25	0	25	50	25	50	75	50	75	100	75	100	100	 5#

(H) Main Boom Load Chart

Unit: Klb





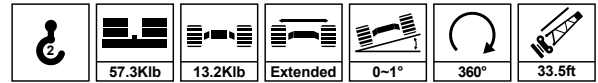

ft	Main Boom Length (ft)															ft	
	40	54.1	61.4	68.6	75.5	82.7	89.2	96.8	104.3	110.9	118.1	125.7	132.5	139.4	154.2		
10	137.4	119.1														10	
12	130.6	114.0														12	
14	119.1	108.2	55.1	78.6												14	
16	108.8	100.8	55.1	74.6	54.3	49.7		49.9								16	
18	99.4	93.0	54.9	70.0	53.2	46.8	54.5	48.3		42.4						18	
20	90.5	85.3	53.0	64.9	50.1	45.0	51.3	45.6	32.3	40.7	32.3		32.8			20	
25	63.1	65.9	48.1	56.0	44.2	39.5	45.3	41.4	28.4	36.8	26.9		25.5			25	
30		47.2	43.5	46.9	39.5	34.7	41.0	37.4	26.2	33.4	24.5		23.7		8.9	30	
35		36.9	39.2	36.7	35.3	31.1	36.6	33.9	23.7	30.6	22.4	17.7	22.0	8.6	8.2	35	
40			32.2	29.0	31.3	28.1	31.3	30.9	21.5	27.6	20.5	16.2	20.6	8.0	7.8	40	
45			25.5	23.1	24.6	25.4	26.1	24.4	20.7	22.9	19.0	15.2	19.2	7.4	7.3	45	
50				18.8	20.1	22.4	21.3	20.1	19.0	20.0	17.5	14.0	17.7	6.9	6.8	50	
55					16.6	19.3	17.4	16.9	17.3	17.2	16.2	13.0	16.6	6.4	6.4	55	
60						16.3	14.6	14.2	15.7	14.4	15.0	12.2	15.4	6.0	6.0	60	
65							14.2	12.4	12.3	13.5	12.4	14.0	11.1	13.1	5.7	5.8	65
70								10.6	10.6	11.8	10.8	11.8	10.6	11.5	5.2	5.4	70
75									9.2	10.2	9.3	10.0	9.9	9.9	4.7	5.1	75
80										8.8	7.9	8.7	9.1	8.5	4.4	4.9	80
85										7.8	6.7	7.6	8.6	7.3	4.2	4.5	85
90											5.8	6.7	8.0	6.3	3.7	3.8	90
95												5.9	7.1	5.4	3.3	3.3	95
100													6.2	4.6	3.0	3.0	100
105														4.0	2.5	2.6	105
110														3.3	2.3	2.3	110
115																1.9	115
	12	10	10	8	8	6	6	6	5	5	5	4	4	3	3		
2#	0	50	0	100	50	0	100	50	0	100	50	0	100	50	100	2#	
3#	0	0	25	0	25	50	25	50	75	50	75	100	75	100	100	3#	
4#	0	0	25	0	25	50	25	50	75	50	75	100	75	100	100	4#	
5#	0	0	25	0	25	50	25	50	75	50	75	100	75	100	100	5#	

(FJ) Fly Jib Load Chart

Unit: Klb





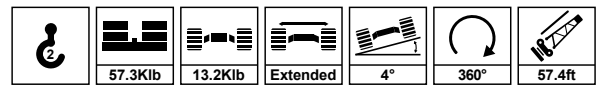

 ft	Main Boom Length (ft)						 ft
	154.2						
	0°	15°	30°	0°	15°	30°	
25	12.1						25
30	11.2						30
35	10.5						35
40	9.8	7.9		9.1			40
45	8.7	7.8		8.8			45
50	8.0	7.5	6.4	8.3			50
55	7.8	7.1	5.9	7.6	6.4		55
60	7.7	6.8	5.6	6.8	6.3	5.3	60
65	7.0	6.4	5.4	6.4	6.1	5.0	65
70	6.3	6.1	5.1	6.3	5.8	4.7	70
75	5.6	5.7	4.9	5.9	5.4	4.4	75
80	4.9	5.4	4.7	5.4	5.1	4.2	80
90	3.9	4.5	4.3	4.2	4.4	4.0	90
100	3.0	3.4	3.5	3.2	3.8	3.7	100
110			2.4	2.4	2.8	2.9	110
120						1.9	120
 Min	52			50			 Min

(FJ) Fly Jib Load Chart

Unit: Klb



 ft	Main Boom Length (ft)						 ft
	154.2						
	0°	15°	30°	0°	15°	30°	
25							25
30							30
35							35
40	6.0						40
45	5.5						45
50	5.0						50
55	4.6	3.8		4.8			55
60	4.3	3.7		4.4			60
65	4.0	3.5		4.0			65
70	3.8	3.4	2.7	3.6	3.1		70
75	3.7	3.2	2.6	3.3	3.0		75
80	3.5	3.1	2.5	3.0	2.9	2.0	80
90	3.2	2.8	2.3	2.9	2.7	2.0	90
100	2.8	2.4	2.2	2.8	2.3	1.9	100
110	2.3	2.1	2.1	2.4	2.0	1.7	110
120			1.9	1.9	1.7	1.5	120
130					1.6	1.3	130
135						1.3	135
 Min	52			50			 Min



SANY
AMERICA

318 Cooper Circle
Peachtree City, GA 30269
Tel: 678-251-2810
Fax: 770-632-7820

We are constantly improving our products and therefore reserve the right to change designs and specifications without notice.
This product brochure may contain illustration and specification of optional equipment and attachment that are not included in the standard scope of supply.