



# SCA4000A

SANY Crawler Crane

440UST(400Tons) Lifting Capacity

Quality Changes the World



Max. lifting moment: 734,126lb×52'6" (333×16=5,328t·m)

Longest boom: 275'7"(84m)

Longest boom+luffing jib: 275'7"+265'9"(84m+81m)

The parameters, pictures and standard/optional equipment are only for reference in this brochure, the actual machine is based on the effective price list and contract.

■ [www.sanyglobal.com](http://www.sanyglobal.com)



## Crawler Crane Series SCA4000A

P03

Main  
Characteristics

- Product Specification
- Safety Devices

P09

Technical  
Parameters

- Major Performance & Specifications
- Outline Dimension
- Transport Dimensions
- Transport Plan
- Self-Assembly Plan

P29

Configurations

- Configurations
- H Configuration
- HDB Configuration
- HJ Configuration
- HJDB Configuration
- HJFJ Configuration
- FJh Configuration
- FJhDB Configuration
- LJ Configuration
- LJDB Configuration



**SCA4000A**  
**SANY CRAWLER CRANE**  
**440UST(400TONS) LIFTING CAPACITY**

QUALITY CHANGES THE WORLD

## Main Characteristics

- Page 04 Product Specification
- Page 07 Safety Devices



## Product Specification



### Cab

- Appearance: The industrial modeling of the cab is designed by Porsche. It has a smooth, elegant and novel appearance, with brand identification, which is a significant breakthrough when compared with traditional engineering machinery. The cab is fitted with sliding door structure, which is suitable for the crawler crane and convenient for the operator. It is adopted with fully-sealed steel frame structure, with a large area of high strength toughened glass installed on the front, side and top, more light-transmitting. The interior space of the cab is spacious and bright, with a broader sight view.
- The suspended seat is shock and noise absorbing, and multi-mode and multi-stage adjustable, thus providing most comfortable driving experience. The famous USA RedDot air conditioner is adopted, with reasonable air outlet and efficient cooling. It takes no more than 20 min to cool the cab from 55°C to 27.5°C. The left and right armrest boxes and auxiliary control boxes are equipped with control handles, control buttons, ignition locks and other components. The seats, control handles and control buttons are arranged according to ergonomic design, fully considering the driver's operation demands and habits. The control box can be adjusted, with the seat, to the most desirable position, bringing more comfortable operation. The cab can tilt up to 25° according to the work demands, and can also rotate to the front part of the rotating bed for the convenience of transport.

### Engine

- Cummins X12-C400 Stage V.
- Rated power: 298kW.
- Rated speed: 2,100rpm.
- Max. output torque: 2,169N·m.
- Speed at maximum output torque: 1,400rpm.

### Main and Auxiliary Load Hoisting Mechanism

- A variable hydraulic motor drives the planetary gear reducer to control the load lifting and lowering of main and aux. hoist winches. A good inching performance is provided. The high-speed mode can realize main and aux. load lifting faster.
- Variable hydraulic motor can realize max. winch speed through displacement adjustment based on electricity flow.
- High-quality spin-resistance wire rope to make sure high safety and longer service life.
- Fold-line machined drum provides high precision and good reliability, making sure the wire rope won't get messy.
- The wire rope lug adopted to make wire rope assembly easier and faster.

Main load hoist mechanism	Drum diameter	24.64"(626mm)
	Rope speed on the outermost work layer	0~459'3"/min (0~140m/min)
	Steel rope diameter	1.02"(26mm)
	Steel rope length of main load hoist	2,952'9"(900m)
	Rated tension of single rope	33,068lb(15t)
Aux. load hoist mechanism	Drum diameter	24.64"(626mm)
	Rope speed on the outermost work layer	0~459'3"/min (0~140m/min)
	Steel rope diameter	1.02"(26mm)
	Steel rope length of aux. load hoist	2,952'9"(900m)
	Rated tension of single rope	33,068lb(15t)

### Boom/Jib/Hoist Mechanism

- Including: luffing mechanisms of the boom, jib and superlift;
- Drums with fold-line grooves are adopted for all luffing devices. Hydraulic motor drives the planetary gear reducer to realize a number of compound functions and good inching performance.

Boom hoist mechanism	Drum diameter	25.24"(641mm)
	Rope speed on the outermost work layer	(0~213'3")×6'7"/min (0~65)×2m/min
	Steel rope diameter	1.02"(26mm)
	Steel rope length of boom hoist	1,084'6"(550m)
Jib luffing mechanism	Drum diameter	25.24"(641mm)
	Rope speed on the outermost work layer	0~328'1"/min (0~100m/min)
	Steel rope length of jib luffing	2,165'4"(660m)
Superlift mast luffing	Drum diameter	25.24"(641mm)
	Rope speed on the outermost work layer	0~328'1"/min (0~100m/min)
	Steel rope length of superlift luffing	2,821'6"(860m)



## Product Specification

### Slewing Mechanism

- The slewing hydraulic system adopts double motor to drive the spur gear through the planetary gear box, which can realize 360° rotation, slewing speed of 0~1.4rpm, stepless speed regulation, no backlash at starting or stopping, stable operation and free slipping function at neutral position.
- Slewing ring: It is adopted with three-row roller type slewing bearing with external gears.

### Carbody

- The hydraulic cylinder drives power pin to be connected with track frame to facilitate the assembly and disassembly. Frame structures are welded by high-strength steel. Larger chassis design greatly improves the stability of the crane. The self-assembled carbody counterweight is 88,183lb(40t), with 44,091lb(20t) at both front and the rear.

### Track Assembly

- Track frame: each track frame is equipped with an independent travel driving device. A hydraulic travel motor drives the planetary gear reducer and realizes independent traveling through the transmission of driving wheel. The travel system is configured with high and low speeds: sufficient traction is provided in low speed to realize travel with 100% load, the high speed can provide higher speed to improve the transit efficiency. The traveling drive can also realize stepless speed change.
- Track shoe: It is made of materials with high strength and high wear resistance through advanced casting process. After being installed on the equipment, its tension can be adjusted through the hydraulic jack, and the shim position can be adjusted to achieve the ideal tension.

### Counterweight

- Counterweight include carbody counterweight , rear counterweight, superlift counterweight, and the details are listed below:

Name	Quantity	Length ft(m)	Width ft(m)	Height ft(m)	Unit Weight lb(t)
Carbody counterweight	4	19' (5.80)	5'7" (1.70)	1'9" (0.33)	22,045 (10)
Rear Counterweight(10t)	12	9'4" (2.85)	7'10" (2.40)	1'7" (0.49)	22,045 (10)
Rear Counterweight Tray	2	10'5" (3.20)	9'3" (2.83)	6' (1.80)	33,068 (15)
Superlift Counterweight (10t)	20	9'4" (2.85)	7'10" (2.40)	1'7" (0.49)	22,045 (10)
Superlift Counterweight Tray	1	32'7" (9.95)	8'10" (2.70)	7'2" (2.20)	19,841 (9)

### Operation equipment

- High-strength steel tubes and plates are adopted.

### Boom

- The boom is a spatial lattice structure of welded tubes with equal section areas of inserts and tapered sections for two ends. The boom top and root are strengthened with steel plates, which is easier for load transfer.
- The boom length ranges from the that of basic boom 78'8''(24m) to to max. length 275'7''(84m) .
- Composition: boom base 39'4''(12m)×1, tapered insert 34'5''(10.5m)×1, connecting tip (boom tip) 4'11''(1.5m)×1, insert section 19'8''(6m)×2, and insert section 39'4''(12m)×4.
- The extension jib shall be installed on the boom top.

### Short Heavy Jib( for wind energy and shield lifting)

- The short heavy jib is a spatial lattice structure of welded tubes with equal section areas of inserts and tapered sections for two ends. The boom top and root are strengthened with steel plates, which is easier for load transfer. The jib is 29'6''(9m) long and can be used for both wind energy and shield lifting.
- Composition: Jib base 14'9''(4.5m)×1, Jib top 14'9''(4.5m)×1.

## Product Specification



### Luffing Jib

- The jib is a spatial lattice structure of welded tubes with equal section areas of inserts and tapered sections for two ends. The boom top and root are strengthened with steel plates, which is easier for load transfer.
- The length of the luffing jib ranges from 68'10"(21m) to 265'8"(81m), increased by every 19'8"(6m).
- Composition: jib base 14'9"(4.5m)×1, jib insert 19'8"(6m)×2, jib insert 39'4"(12m)×5, jib top 14'9"(4.5m)×1.
- The extension jib shall be installed on the luffing jib top.

### Superlift Device

- The superlift mast is a spatial lattice structure of welded tubes with equal section areas of inserts and tapered sections for two ends. The boom top and root are strengthened with steel plates, which are easier for load transfer.
- The superlift mast is 98'4"(30m) long.
- Composition: mast base 39'4"(12m)×1, insert section 19'8"(6m)×1, and mast top 39'4"(12m)×1.

### Hook

- 5 kinds of hooks are available, and specific parameters are as follows:

Name of Hook	Max. Lifting Capacity	Quantity	Pulleys	Unit Weight
440UST(400t) hook	440UST(400t)	1	2×9	23,148lb(10.5t)
286UST(260t) hook	286UST(260t)	1	9	10,582lb(4.8t)
176UST(160t) hook	176UST(160t)	1	5	8,377lb(3.8t)
55UST(50t) hook	55UST(50t)	1	1	3,748lb(1.7t)
18UST(16t) ball hook	18UST(16t)	1	-	1,984lb(0.9t)

- The hook height limit:

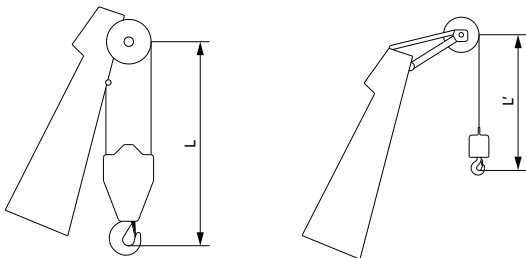

Hook	Length (m)	Hook	Length (m)
440UST(400t) hook	24'11"(7.6)	18UST(16t) hook	15'1"(4.6)
286UST(260t) hook	20'11"(6.4)		
176UST(160t) hook	20'4"(6.2)		
55UST(50t) hook	18'4"(5.6)		

### Hydraulic System

- The whole hydraulic system includes that of hoisting, traveling, slewing, luffing, servo, back-stop, cooling system, and auxiliary hydraulic system. Major hydraulic components are of famous brand.
- Features: lifting, traveling, luffing, and slewing hydraulic systems are applied with open circuits, which has advantages such as energy saving, high efficiency, quick response, low heat generation and long service life.
- Electrically-controlled proportional control components are adopted for the servo system to realize precise and intelligent control.
- The back-stop hydraulic system adopts balance valve of external control and unloading, and it is mounted on the cylinder to make sure it is safe and reliable.
- The cooling hydraulic system is featured with large heat exchange power and good cooling effect.

### Operating Weight

- The operating weight is about 749,559lb(340t), including the upperworks, lowerworks, rear counterweight of basic machine, carbody counterweight, 78'8"(24m) basic boom and 440UST(400t) hook.

### Ground Pressure

- The average ground pressure of machine with basic boom is 0.167MPa.

### Gradeability

- The gradeability of machine with basic boom is 15%.



## Safety Devices

### Load Moment Indicator

- The proprietary load moment indicator independently developed by Sany is adopted, which forms a network with other controllers through CAN bus line, so as to realize safe and reliable control. The load moment indicator can automatically detect the hoisting weight of the crane and the angle of the boom, and display the rated load capacity, actual load, working radius, and the allowable height of the hook.
- The load moment indicator system consists of a large-screen color display, a host computer, angle sensors, tension sensors, pressure sensors and other components.

### Over-hoist Protection of the Main and Auxiliary Hooks

- It is used to prevent the over-hoist of the hook. When the lifting hook is raised to a certain height, the limit switch will start working, and hook will be automatically cut off from moving up by the control system. Meanwhile, the display and the buzzer will give alarms. At this moment, only hook lowering is allowed to prevent over-hoist action.

### Over-release Protection Device of the Main and Auxiliary Hook

- It is used to prevent the wire rope over-release. When the wire rope is released to the last three wraps, the limit switch will start working, and the releasing of rope will be automatically stopped by the control system. Meanwhile, the display and the buzzer will give alarms. At this moment, only rope retraction is allowed to prevent over release action.

### Assembly/Work Mode Switchover

- In Assembly Mode, some of the safety devices cannot function properly, such as jib limit, boom angle limit in LML, and overload, so as to facilitate the crane assembly.
- In Work Mode, all safety devices can function properly.

### Boom Angle Limit

- When the elevation angle of the boom exceeds 85° or jib angle exceeds 75°, corresponding limit switch will be triggered, and the control system will automatically cut off the boom hoisting. Meanwhile, the display and the buzzer will give alarm. At this moment, boom/jib luffing winch won't hoist but it can still lower down.
- When the boom down angle is less than 30° or jib down angle is less than 15°, the control system will automatically cut off the boom/jib from further lowering. Meanwhile, the display and the buzzer will give alarms. At this moment, boom/jib luffing winch won't be able to lower. This protection is automatically controlled by Load Moment Limiter.

### Back-stop Device

- The boom and the superlift mast are respectively equipped with a pair of back-stop cylinders. The high pressure of the cylinder shall be overcome when the boom tilts backwards, and high pressure oil will be supplemented automatically when the boom swings forwards to increase the tension and prevent the boom vibration and shaking back.
- The jib rear mast is equipped with a pair of back-stop cylinders, while the jib front mast is equipped with a pair of pneumatic cylinders to prevent the mast from the backward inclination and tension of the jib luffing wire rope.

### Brake of Hoisting Mechanism

- All hoisting brakes are spring loaded normally closed disc brakes, which are featured with large braking force, maintenance-free, safe and reliable use, and long service life.

### CCTV Monitoring System

- It can be used to monitor the winding conditions of wire ropes of each hoisting mechanism, the conditions of superlift weight, and conditions around the equipment.

### Fault Auto-Diagnosis System

- Faults can be conveniently eliminated based on the fault code.

### Black Box

- It is able to record the operation data and machine movement, and analyze the remaining running conditions and service life of machine based on the actual performance.

### Pharos

- It is mounted on the top of the boom/jib and alerts in air during night.

### Anemometer

- It is mounted on the top of the boom/jib to monitor the wind speed in real time and display relative data on the monitor.

## Safety Devices



### Electronic Level Indicator

- It displays the tilting angle of the crane on the monitor in real time and protects the safe operation of the crane.

### Lightning Protection Device

- It includes the lightning protection device and the surge protection device, which can effectively protect the electric system elements and workers from lightning.

### Hook Latch

- The lifting hook is installed with a baffle plate to prevent wire rope from falling off.

### Swing and Traveling Alarm

- During swing and traveling, the alarm horn will be blown per certain frequency to alert the personnel around the crane. The horn can be shut off through the display.

### Seat interlock

- The operation will be locked by pulling up the function locking lever on the right side of the seat inside the driver's cab or when the operator left the seat, after which no operating handles will be working so that improper operation caused by the body collision when getting on and off the crane can be avoided.

### Regulation of Engine Power Ultimate Load and Stalling Protection

- The controller can monitor the engine power so as to prevent stalling.

### Engine Status Monitoring

- It can show the engine coolant temperature, fuel volume, total working hours, engine oil pressure, engine speed, battery and voltage.

### Remote Monitoring System

- It monitors and analyzes the operation data so as to realize remote diagnosis of faults and timely solution.

### Emergent Stop

- In a sudden loss of control, press the emergent stop, all actions such as hoisting, luffing, swinging and traveling brake and engine stops.





**SCA4000A**  
**SANY CRAWLER CRANE**  
**440UST(400TONS) LIFTING CAPACITY**

QUALITY CHANGES THE WORLD

## Technical Parameters

- Page 10 Major Performance & Specifications
- Page 11 Outline Dimension
- Page 13 Transport Dimensions
- Page 20 Transport Plan
- page 23 Self-Assembly Plan



## Major Performance & Specifications

Major Performance & Specifications of SCA4000A		
Performance Indicators	Unit	Parameter
Max. rated lifting capacity	lb(t)	881,834 (400)
Max. rated lifting moment	lb-ft(t·m)	848,765×23' (2,695=385×7)
Max. rated lifting moment (with superlift)	lb-ft(t·m)	734,162×52'6" (5,328=333×16)
Boom length (H)	ft(m)	78'8" ~275'7" (24~84)
Boom length (HDB with superlift)	ft(m)	118'1" ~275'7" (36~84)
Length of mixed boom (HJ)	ft(m)	147'7" ~324'9" (45~99)
Length of mixed boom (HJDB with superlift)	ft(m)	226'4" ~403'6" (69~123)
Length of luffing jib (LJ)	ft(m)	68'10" ~226'4" (21~69)
Length of luffing jib (LJDB with superlift)	ft(m)	68'10" ~265'8" (21~81)
Combination of longest boom+luffing jib (LJDB Configuration)	ft(m)	275'7" ~265'8" (84+81)
Heavy boom for wind energy	ft(m)	29'6" (9)
Boom + Fixed jib (FJh Configuration)	ft(m)	78'8" +29'6" (24+9)
Boom + Fixed jib(FJhDB Configuration)	ft(m)	118'1" +29'6" (36+9)
Boom + Mixed boom + Fixed jib (HJFJ Wind energy)	ft(m)	295'3" +29'6" (90+9)
Angle of boom hoisting	°	30~85
Angle of jib luffing	°	15~75
Max. speed of single rope of the main load hoist	ft/min (m/min)	0~459 (0~140)
Max. speed of single rope of the aux. load hoist	ft/min (m/min)	0~459 (0~140)
Max. speed of single rope of the boom hoisting	ft/min (m/min)	(0~213)×2 (0~65)×2
Max. speed of single rope of the jib luffing	ft/min (m/min)	(0~328) (0~100)
Max. speed of single rope of the superlift luffing	ft/min (m/min)	(0~328) (0~100)
Slewing speed (no load)	r/min	0~1.4
Travel speed	mile/h (km/h)	0~0.6(high)/0~0.2(low) 0~1(high)/0~0.4(low)
Gradeability (with basic boom, driver's cab backwards)	%	15
Rated output power of the engine	kW/rpm	298/2,100
Average ground pressure of the track (basic boom, 330,688lb(150t) rear counterweight, 88,183lb(40t) carbody weight, and 440UST(400t) hook)	MPa	0.167
Max. transport dimension of single piece (L × W × H)	ft(mm)	39'4" ×9'10" ×10'10" (12,000×3,000×3,300)
Max. transport weight of single piece	lb(t)	91,049(41.3)

Unit: mm

**Outline Dimension**

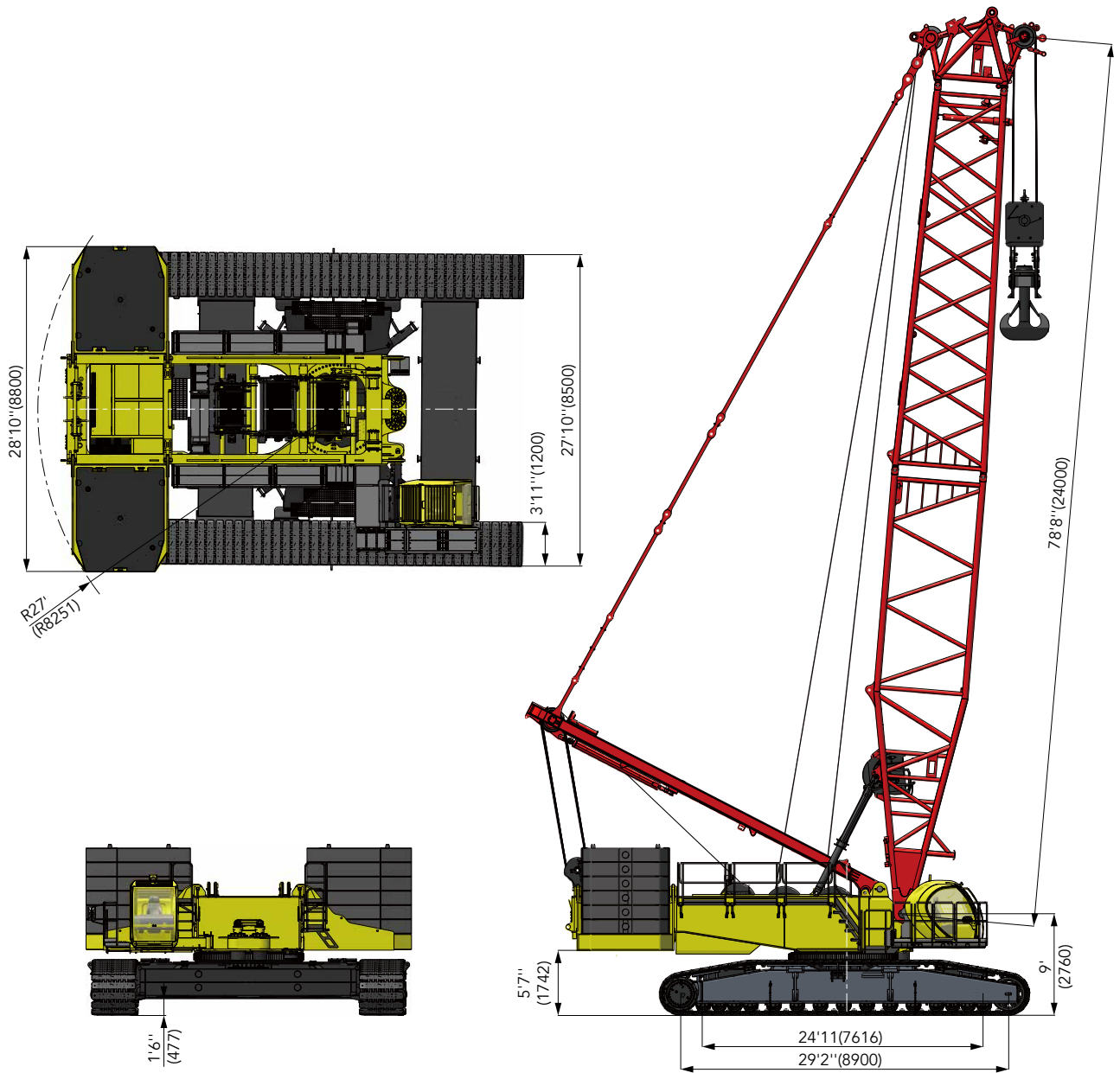

**Outline Dimension**

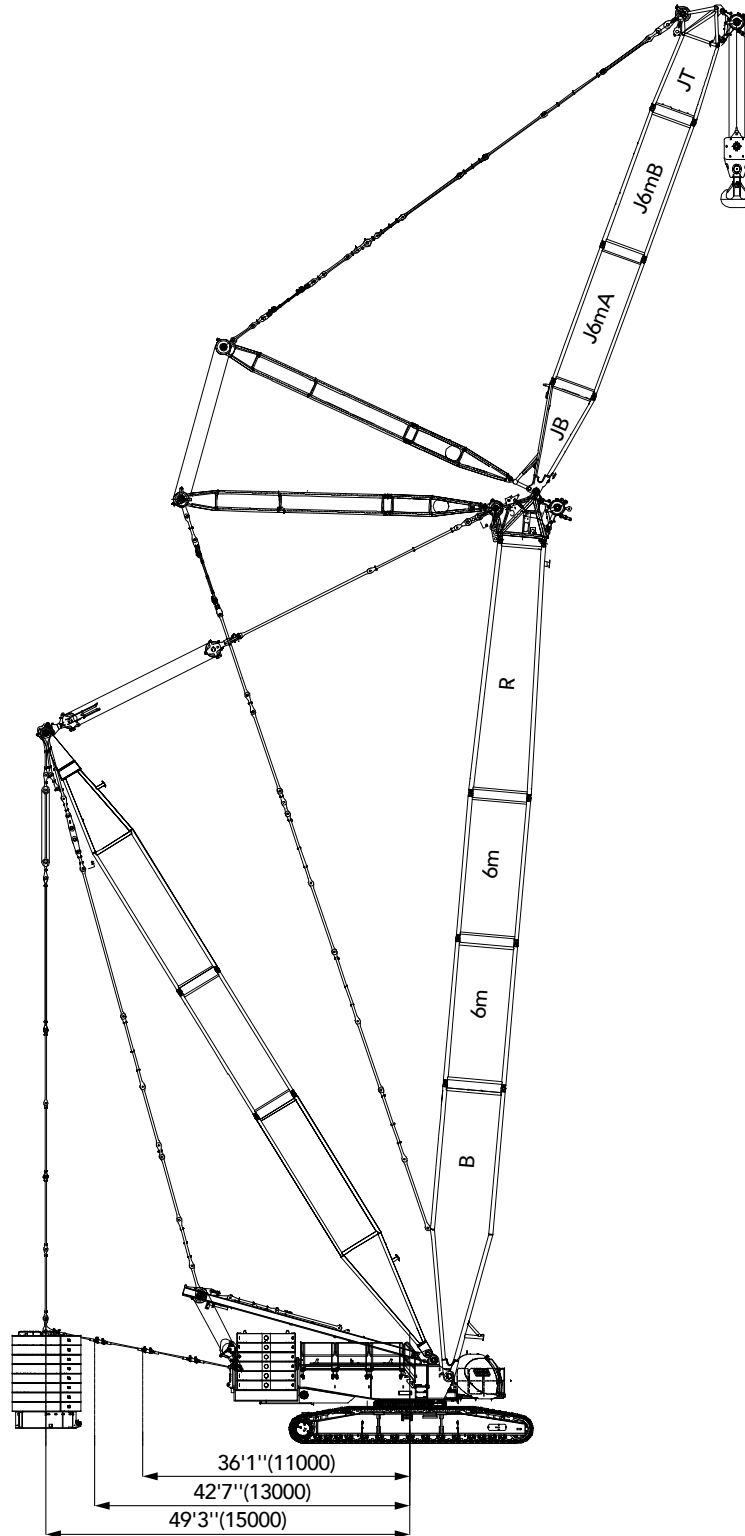

## Transport Dimensions

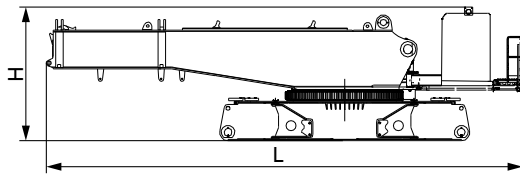

### Basic machine ×1

Length(L)	39'4"(12.00m)
Width(W)	9'10"(3.00m)
Height(H)	10'10"(3.30m)
Weight	91,049lb(41.3)

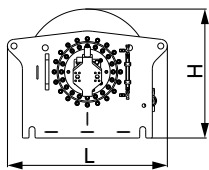

### Hoist mechanism ×2

Length(L)	6'(1.83m)
Width(W)	4'3"(1.32m)
Height(H)	3'6"(1.07m)
Weight	12,125lb(5.5t)

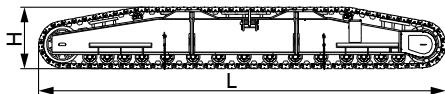

### Crawler ×2

Length(L)	32'11"(10.05m)
Width(W)	5'4"(1.62m)
Height(H)	4'11"(1.51m)
Weight	58,421lb(26.5t)

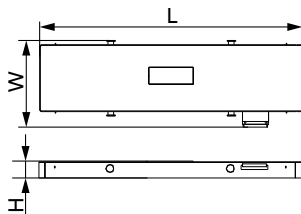

### Upper carbody counterweight ×2

Length(L)	19'4"(5.89m)
Width(W)	6'4"(1.94m)
Height(H)	1'2"(0.36m)
Weight	22,045lb(10.0t)

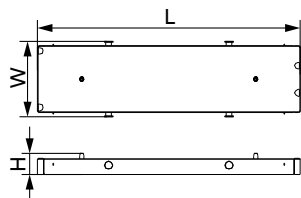

### Lower carbody counterweight ×2

Length(L)	19'4"(5.89m)
Width(W)	5'6"(1.70m)
Height(H)	1'2"(0.36m)
Weight	22,045lb(10.0t)

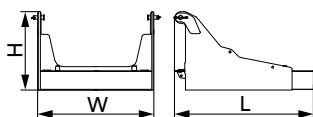

### Rear counterweight tray ×2

Length(L)	10'6"(3.20m)
Width(W)	8'9"(2.67m)
Height(H)	5'10"(1.80m)
Weight	33,068lb(15.0t)

## Transport Dimensions

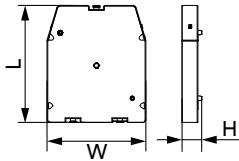

### 22,045lb(10t) counterweight block ×32

Length(L)	9'4''(2.85m)
Width(W)	8'10''(2.40m)
Height(H)	1'7''(0.49m)
Weight	22,045lb(10.0t)

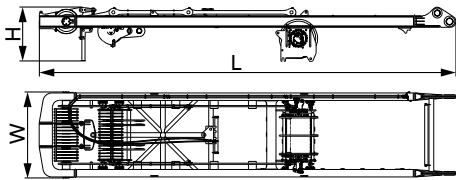

### Boom hoist mast with winch ×1

Length(L)	35'8''(10.87m)
Width(W)	7'4''(2.24m)
Height(H)	4'6''(1.38m)
Weight	24,448lb(11.09t)

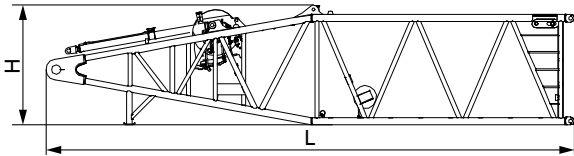

### Boom base with jib luffing winch ×1

Length(L)	40'8''(12.40m)
Width(W)	9'10''(3.00m)
Height(H)	9'2''(2.79m)
Weight	28,703lb(13.02t)

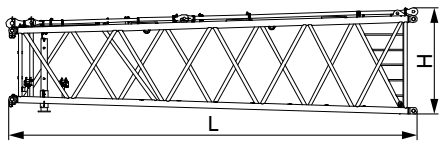

### Tapered insert of boom ×1

Length(L)	35'(10.68m)
Width(W)	9'8''(2.96m)
Height(H)	9'2''(2.79m)
Weight	11,463lb(5.2t)

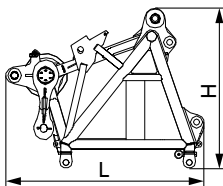

### Boom tip ×1

Length(L)	7'8''(2.34m)
Width(W)	8'6''(2.59m)
Height(H)	8'6''(2.60m)
Weight	7,892lb(3.58t)

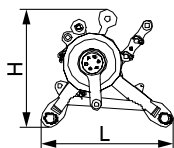

### Sheave block ×3

Length(L)	4'7''(1.42m)
Width(W)	4'6''(1.36m)
Height(H)	4'2''(1.27m)
Weight	2,050lb(0.93t)

## Transport Dimensions

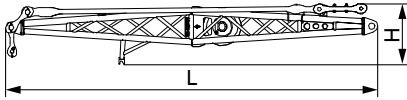

### Fixed jib mast ×1

Length(L)	20'4''(6.20m)
Width(W)	8'1''(2.47m)
Height(H)	3'7''(1.10m)
Weight	5,291lb(2.4t)

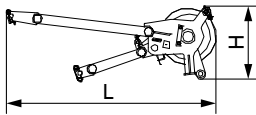

### Extension jib ×1

Length(L)	7'3''(2.22m)
Width(W)	3'3''(1.00m)
Height(H)	4'8''(1.43m)
Weight	793lb(0.36t)

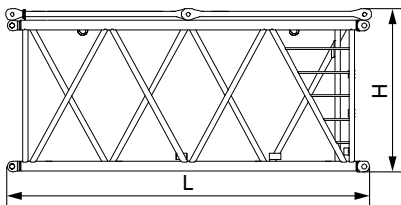

### 19'8''(6m) boom insert ×2

Length(L)	20'6''(6.24m)
Width(W)	9'8''(2.96m)
Height(H)	9'1''(2.78m)
Weight	5,511lb(2.5t)

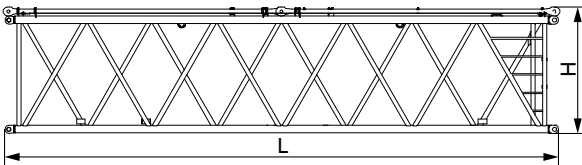

### 39'4''(12m) boom insert A ×1

Length(L)	40'2''(12.24m)
Width(W)	9'8''(2.96m)
Height(H)	9'1''(2.78m)
Weight	10,141lb(4.6t)

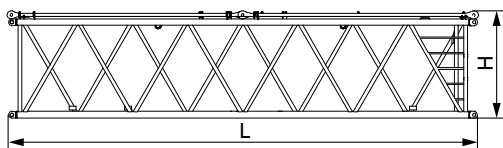

### 39'4''(12m) boom insert B ×3

Length(L)	40'2''(12.24m)
Width(W)	9'8''(2.96m)
Height(H)	9'1''(2.78m)
Weight	8,818lb(4.0t)

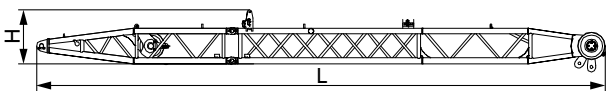

### Front mast of luffing jib ×1

Length(L)	44'1''(13.44m)
Width(W)	7'1''(2.18m)
Height(H)	4'10''(1.48m)
Weight	7,275lb(3.3t)

## Transport Dimensions

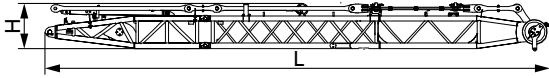

### Rear mast of luffing jib

×1

Length(L)	42'5''(12.94m)
Width(W)	9'8''(2.94m)
Height(H)	4'3''(1.29m)
Weight	11,243lb(5.1t)

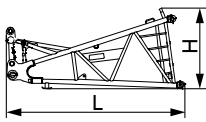

### Luffing jib base

×1

Length(L)	15'7''(4.74m)
Width(W)	8'5''(2.56m)
Height(H)	7'6''(2.30m)
Weight	5,291lb(2.4t)

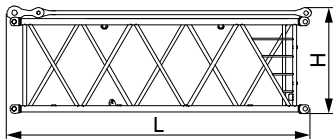

### 19'8''(6m) luffing jib insert I

×1

Length(L)	20'7''(6.28m)
Width(W)	8'5''(2.56m)
Height(H)	7'6''(2.28m)
Weight	4,409lb(2.0t)

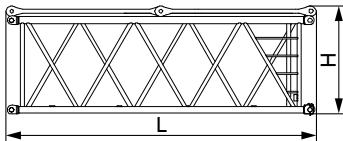

### 19'8''(6m) luffing jib insert II

×1

Length(L)	20'8''(6.30m)
Width(W)	8'6''(2.60m)
Height(H)	7'6''(2.30m)
Weight	3,747lb(1.7t)

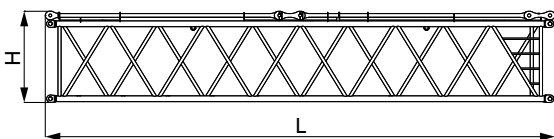

### 39'4''(12m) luffing jib insert A

×1

Length(L)	40'2''(12.24m)
Width(W)	8'5''(2.56m)
Height(H)	7'2''(2.19m)
Weight	6,172lb(2.8t)

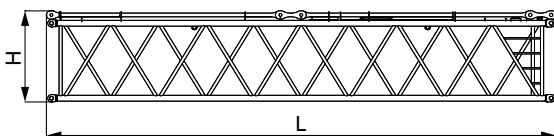

### 39'4''(12m) luffing jib insert B

×4

Length(L)	40'2''(12.24m)
Width(W)	8'5''(2.56m)
Height(H)	7'2''(2.19m)
Weight	6856lb(3.11t)



## Transport Dimensions

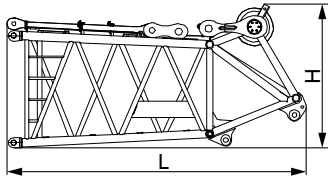

Luffing jib top		×1
Length(L)	16'7"	(5.05m)
Width(W)	8'5"	(2.56m)
Height(H)	7'11"	(2.43m)
Weight	6,613lb	(3.0t)

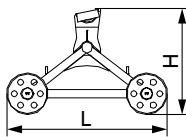

Trolley		×1
Length(L)	6'7"	(2.02m)
Width(W)	4'	(1.23m)
Height(H)	4'4"	(1.33m)
Weight	1,322lb	(0.6t)

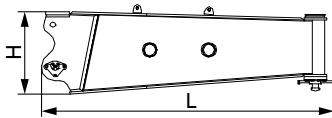

Side outrigger		×2
Length(L)	11'11"	(3.63m)
Width(W)	2'7"	(0.78m)
Height(H)	3'5"	(1.05m)
Weight	4,188lb	(1.9t)

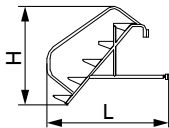

Ladder		×2
Length(L)	4'1"	(1.25m)
Width(W)	1'10"	(0.56m)
Height(H)	4'	(1.22m)
Weight	110lb	(0.05t)

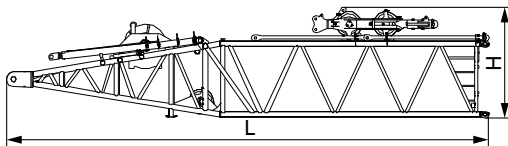

Superlift mast base		×1
Length(L)	40'3"	(12.28m)
Width(W)	9'10"	(3.00m)
Height(H)	9'5"	(2.86m)
Weight	36,816lb	(16.7t)

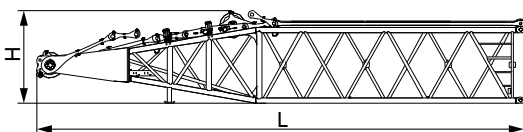

Superlift mast top		×1
Length(L)	10'9"	(12.42m)
Width(W)	9'6"	(2.90m)
Height(H)	7'10"	(2.40m)
Weight	18,738lb	(8.5t)

## Transport Dimensions

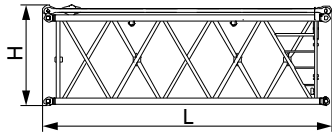

### Superlift mast insert

×1

Length(L)	20'3''(6.18m)
Width(W)	9'6''(2.90m)
Height(H)	7'6''(2.15m)
Weight	5,511lb(2.5t)

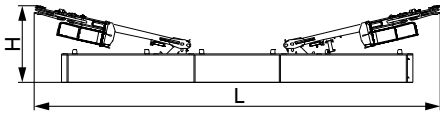

### Superlift counterweight tray

×1

Length(L)	32'8''(9.95m)
Width(W)	8'10''(2.70m)
Height(H)	7'2''(2.20m)
Weight	19,841lb(9.0t)

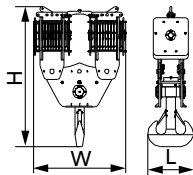

### 440UST(400t) hook of dual sheave blocks

×1

Length(L)	3'4''(1.02m)
Width(W)	8'10''(2.69m)
Height(H)	13'4''(4.07m)
Weight	23,148lb(10.5t)

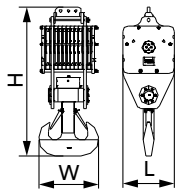

### 286UST(260t) hook

×1

Length(L)	3'4''(1.02m)
Width(W)	3'8''(1.13m)
Height(H)	9'7''(2.93m)
Weight	10,582lb(4.8t)

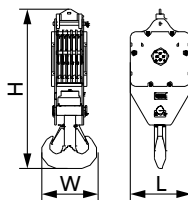

### 176UST(160t) hook

×1

Length(L)	1'11''(0.60m)
Width(W)	3'4''(1.02m)
Height(H)	8'8''(2.65m)
Weight	6,834lb(3.1t)

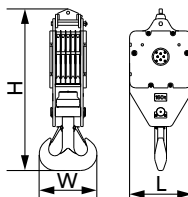

### 55UST(50t) hook

×1

Length(L)	1'11''(0.60m)
Width(W)	2'6''(0.77m)
Height(H)	6'10''(2.11m)
Weight	3,747lb(1.7t)

## Transport Dimensions

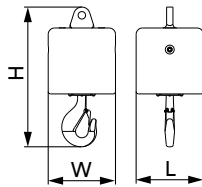

### 18UST(16t) hook ×1

Length(L)	1'8"(0.53m)
Width(W)	1'8"(0.53m)
Height(H)	3'7"(1.10m)
Weight	1,984lb(0.9t)

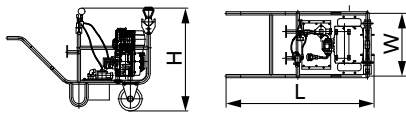

### Portable hydraulic power pack system ×1

Length(L)	1'9"(0.54m)
Width(W)	9"(0.23m)
Height(H)	1'3"(0.38m)
Weight	413.6lb(0.19t)

Note:

1. The transport dimensions of each part in the table are schematic, not proportional to the real parts. The dimensions are designed value without package considered.
2. Weight is designed value that the actual manufactured part may deviate a little.
3. The dimensions and weight of each part may change due to product upgrading. The final values are subject to the new product.

## Transport Plan

Transport weight	▪ 91,049lb(41.3t)
Part	▪ Basic machine×1
Truckload	▪ 1

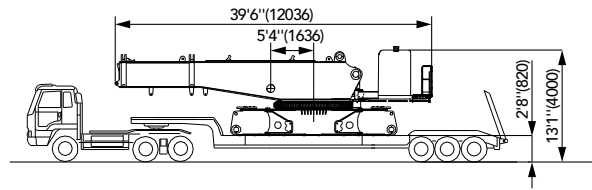

Transport weight	▪ 58,421lb(26.5t)
Part	▪ Left track frame×1
Truckload	▪ 2

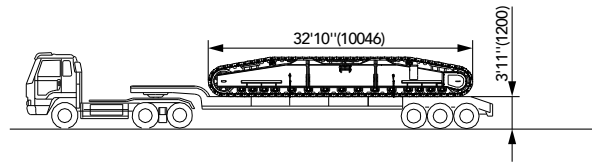

Transport weight	▪ 36,596lb(16.6t)
Part	▪ Boom hoist mast×1 ▪ Main hoist winch×1 ▪ Boom hoist winch×1
Truckload	▪ 1

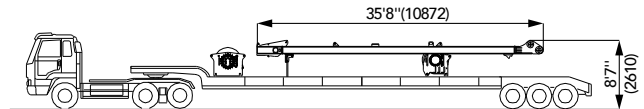

Transport weight	▪ 38,360lb(17.4t)
Part	▪ 22,045lb(10t) counterweight block×1 ▪ 12m boom insert A×1 ▪ 12m luffing jib insert B×1
Truckload	▪ 1

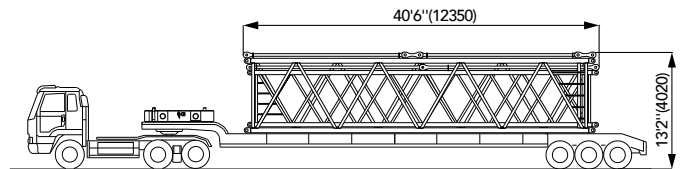

Transport weight	▪ 37,037lb(16.8t)
Part	▪ 22,045lb(10t) counterweight block×1 ▪ 12m boom insert B×1 ▪ 12m luffing jib insert B×1
Truckload	▪ 3

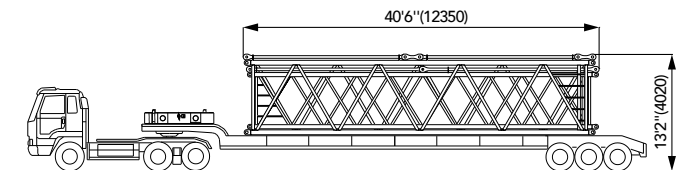

Transport weight	▪ 40,564lb(18.4t)
Part	▪ 22,045lb(10t) counterweight block×1 ▪ Front mast of luffing jib×1 ▪ Rear mast of luffing jib×1
Truckload	▪ 1

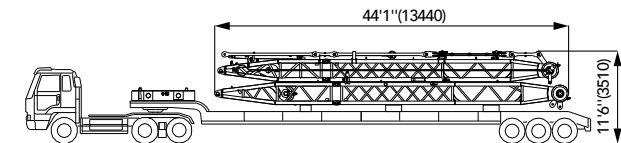

Transport weight	▪ 41,226lb(18.7t)
Part	▪ Boom base×1 ▪ Jib luffing winch×1 ▪ 18UST(16t) ball hook×1 ▪ 286UST(260t) lifting hook×1
Truckload	▪ 1

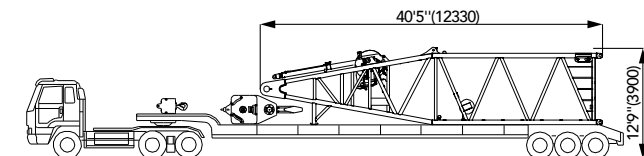

## Transport Plan

Transport weight	▪ 41,227lb(18.7t)
Part	▪ 6m luffing jib 1x1 ▪ Rear counterweight trayx1 ▪ 55UST(50t) hookx1
Truckload	▪ 1

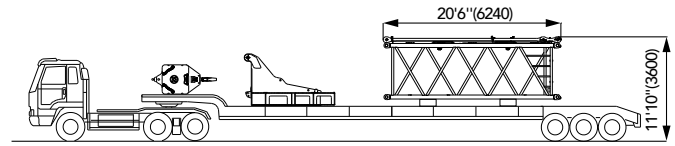

Transport weight	▪ 43,651lb(19.8t)
Part	▪ 6m luffing jib 11x1 ▪ Rear counterweight trayx1 ▪ 176UST(160t) hookx1
Truckload	▪ 1

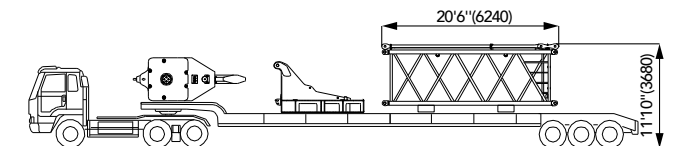

Transport weight	▪ 42,989lb(19.5t)
Part	▪ Superlift counterweight trayx1 ▪ 440UST(400t) hook of dual sheave blocksx1
Truckload	▪ 1

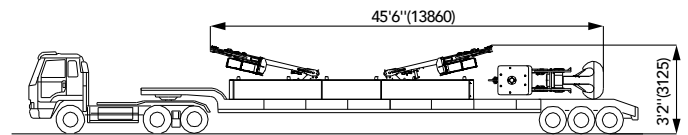

Transport weight	▪ 42,430lb(19.7t)
Part	▪ 22,045lb(10t) counterweight blockx1 ▪ Tapered insert of boomx1 ▪ Boom tipx1 ▪ Sheave blockx1
Truckload	▪ 1

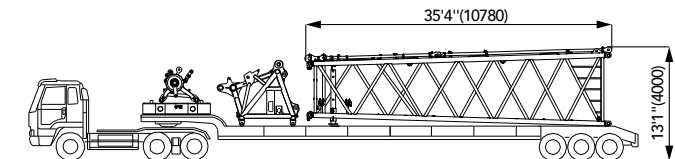

Transport weight	▪ 39,682lb(18t)
Part	▪ Superlift mast basex1 ▪ Superlift luffing winchx1 ▪ Sheave blockx1 ▪ Extension jibx1
Truckload	▪ 1

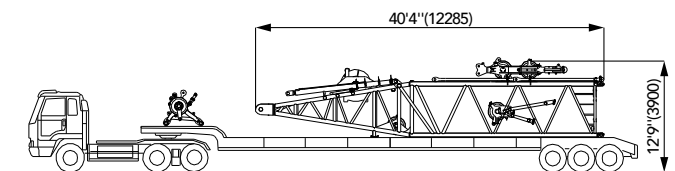

Transport weight	▪ 44,974lb(20.4t)
Part	▪ Superlift mast boom topx1 ▪ 22,045lb(10t) counterweight blockx1 ▪ Side outriggerx1
Truckload	▪ 1

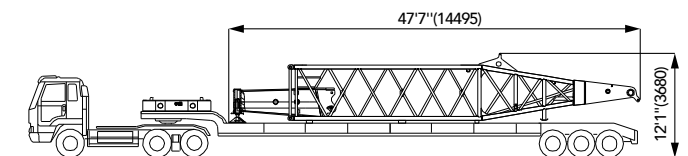

Transport weight	▪ 37,698lb(17.1t)
Part	▪ 22,045lb(10t) counterweight blockx1 ▪ Superlift mast boom insertx1 ▪ 6m boom insertx1 ▪ Portable hydraulic power pack systemx1 ▪ Attachment partsx1 ▪ Side outriggerx1
Truckload	▪ 1

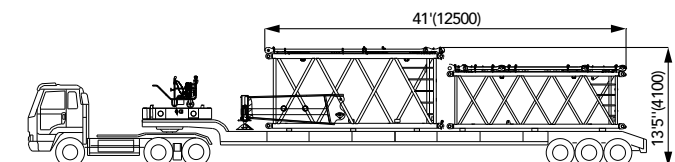

## Transport Plan

Transport weight	▪ 44,091lb(20t)
Part	▪ Upper carbody counterweight×1 ▪ Lower carbody counterweight×1
Truckload	▪ 2



Transport weight	▪ 23,810lb(10.8t)
Part	▪ 6m boom insert×1 ▪ Aux. hoist winch×1
Truckload	▪ 1

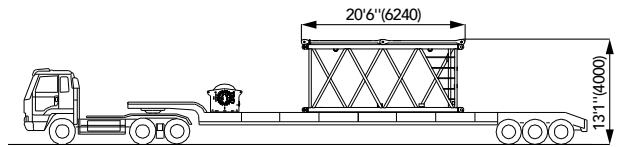

Transport weight	▪ 30,203lb(13.7t)
Part	▪ 12m luffing jib insert A×1 ▪ 22,045(10t) counterweight block×1 ▪ Trolley×1
Truckload	▪ 1

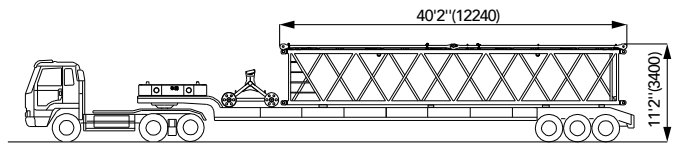

Transport weight	▪ 32,628lb(14.8t)
Part	▪ Luffing jib base×1 ▪ Fixed jib mast×1 ▪ 22,045(10t) counterweight×1
Truckload	▪ 1

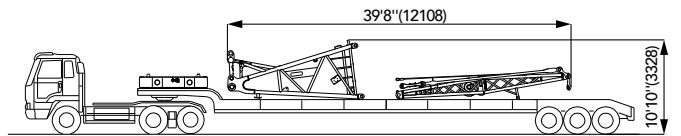

Transport weight	▪ 44,091lb(20t)
Part	▪ 22,045(10t) counterweight block×2
Truckload	▪ 11

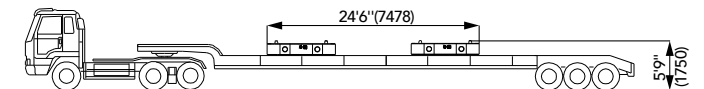

Note:  
the transport combinations listed above is just some of the transport plans, for reference only;  
Actual transport plan shall be determined by parts of Configurations as below, trailer, and transport regulation.

## Self-Assembly Plan

### Basic machine self-assembly

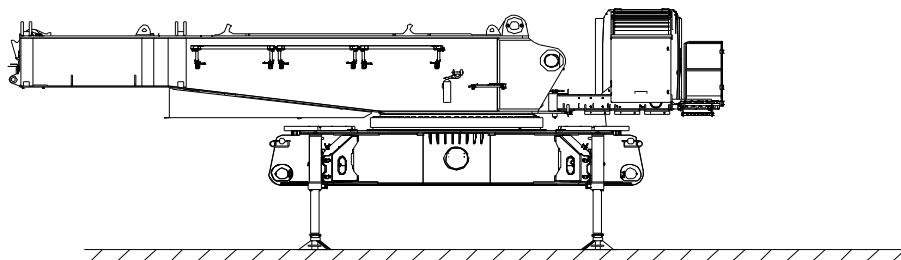
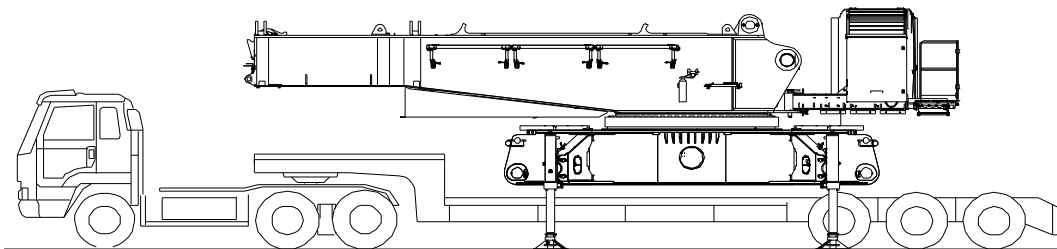
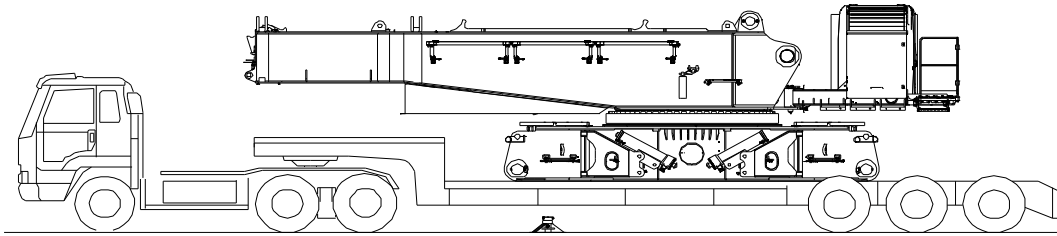

Note: The schematics above are reference for self-assembly method only.

## Self-Assembly Plan

### Crawler frame self-assembly

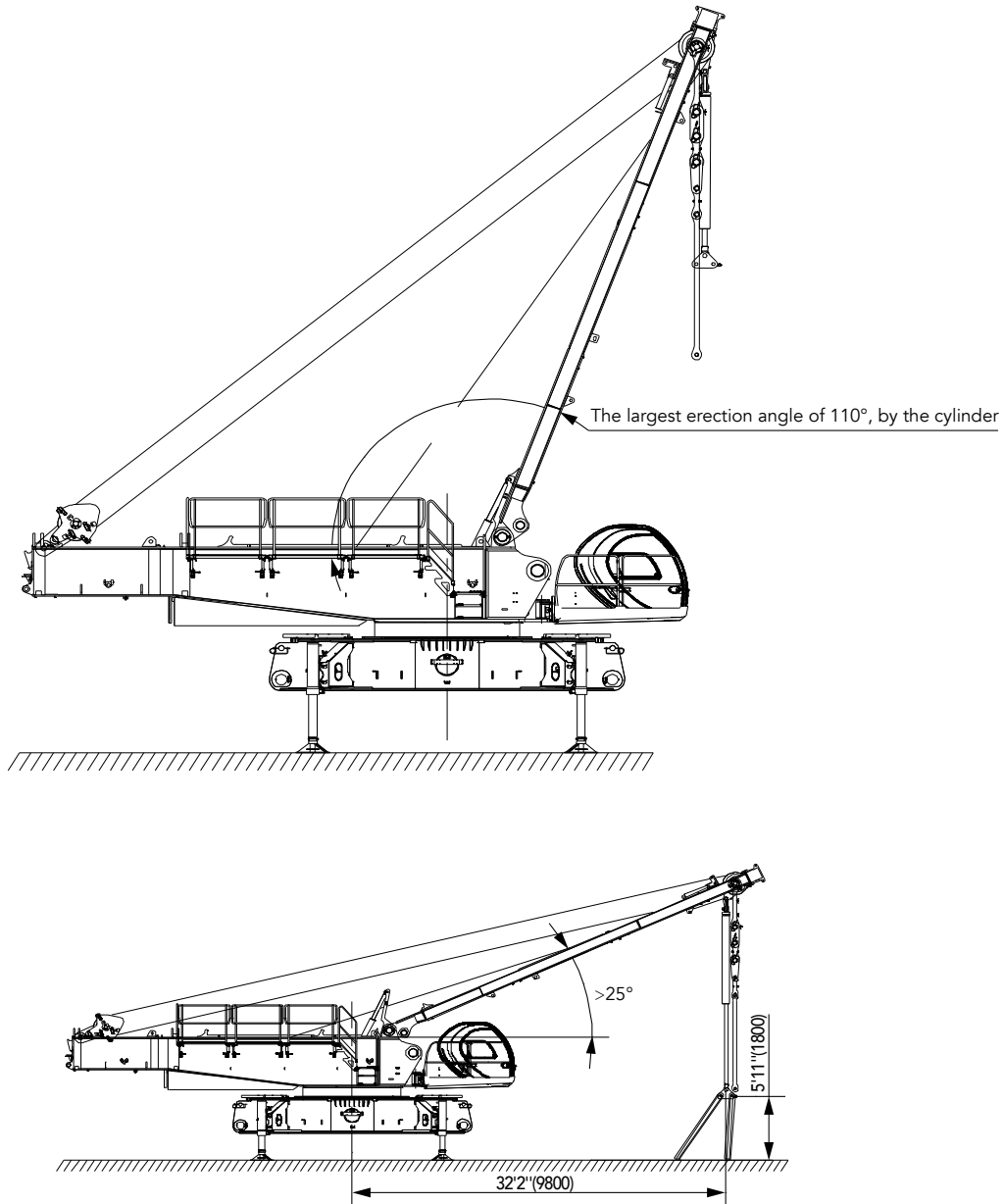

Note: The schematics above are reference for self-assembly method only.



## Self-Assembly Plan

### Crawler frame self-assembly

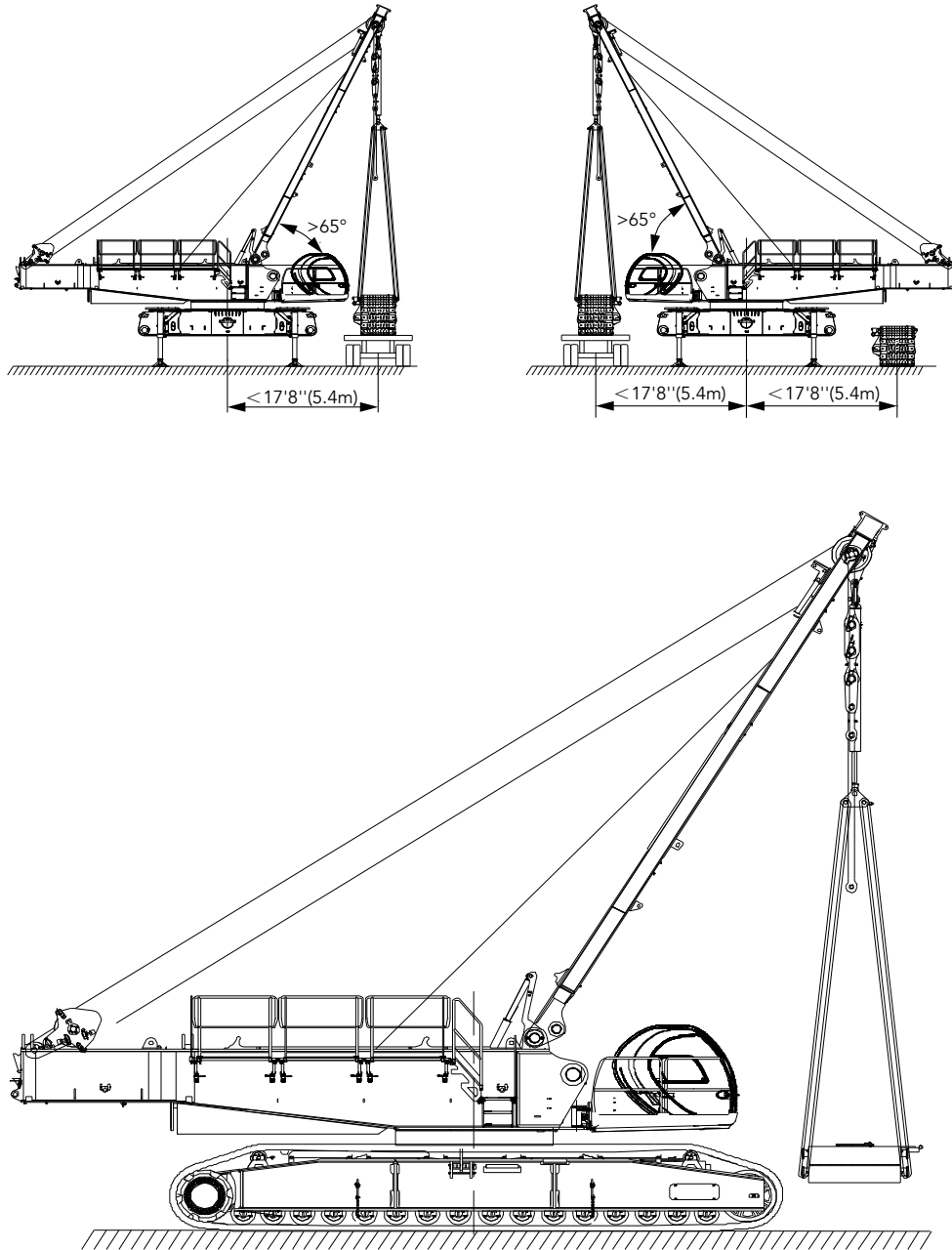

Note: The schematics above are reference for self-assembly method only.

## Self-Assembly Plan

### Boom assembly

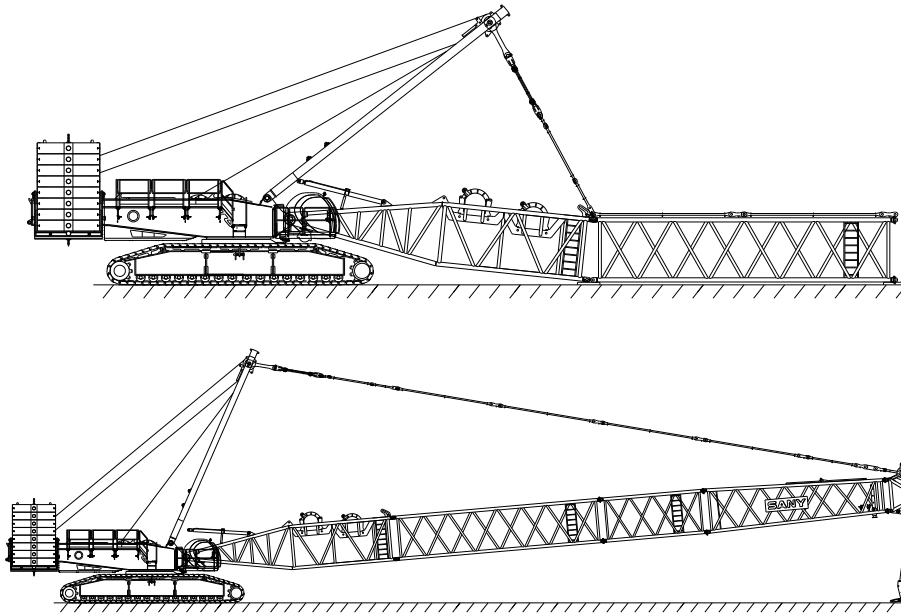

### Superlift mast assembly

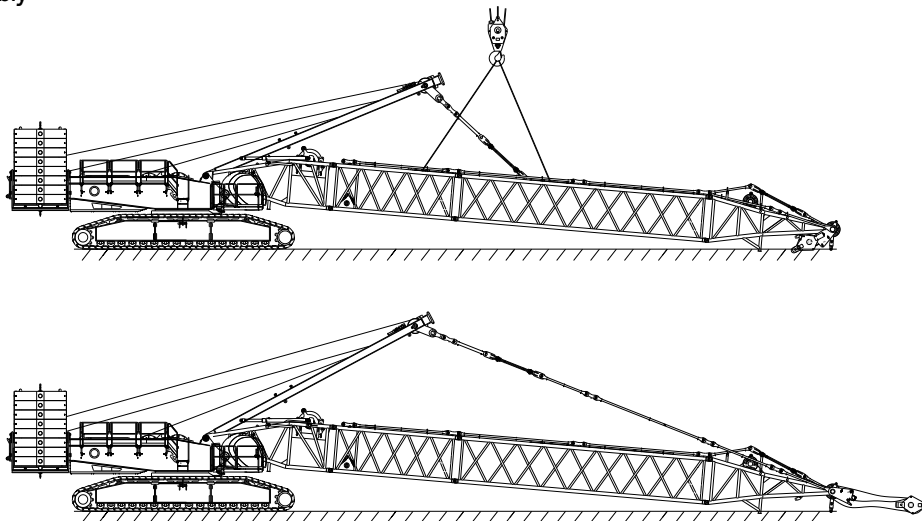

Note: The schematics above are reference for self-assembly method only.

## Self-Assembly Plan

### Luffing jib assembly

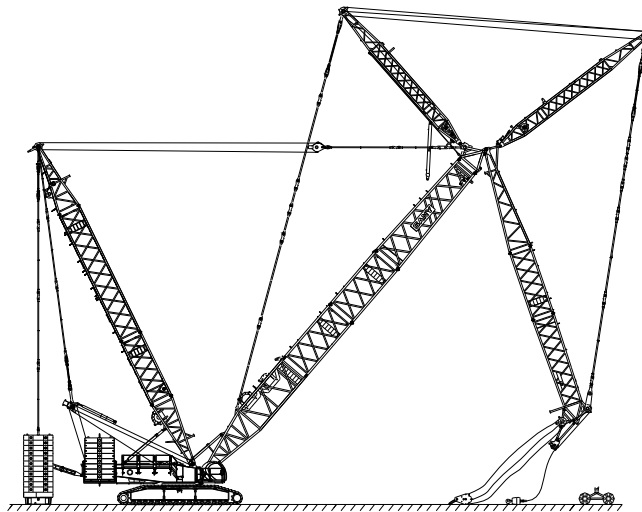
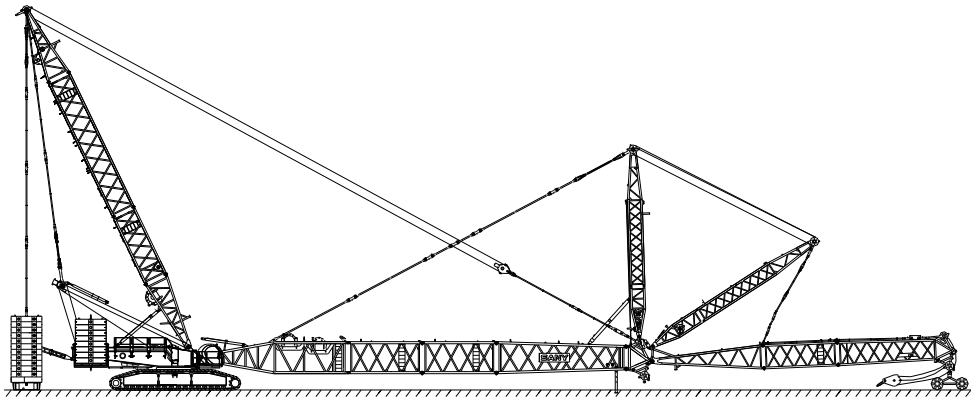

Note: The schematics above are reference for self-assembly method only.

## Self-Assembly Plan

### Fixed jib assembly

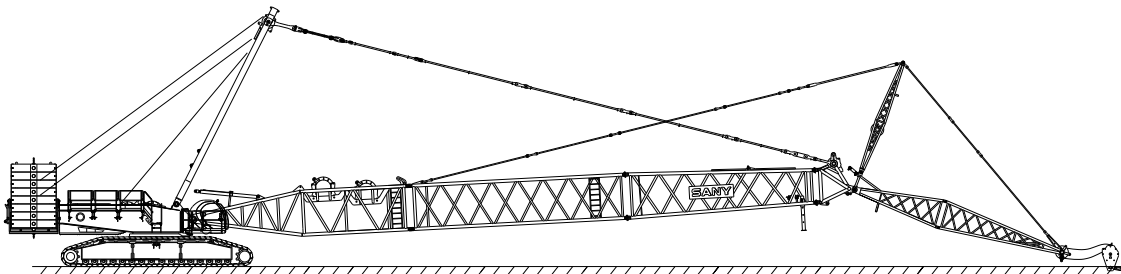
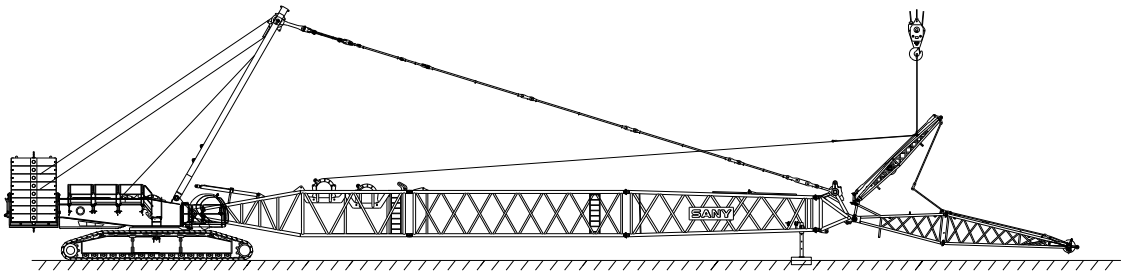
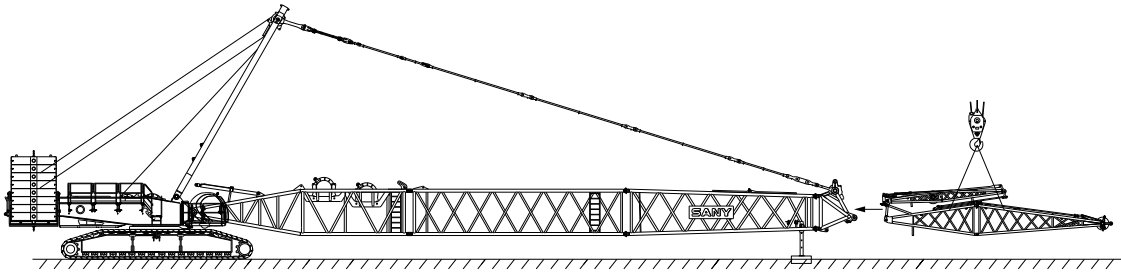

Note: The schematics above are reference for self-assembly method only.



**SCA4000A**  
**SANY CRAWLER CRANE**  
**440UST(400TONS) LIFTING CAPACITY**

QUALITY CHANGES THE WORLD

## Cofigurations

- Page 30 Configurations
- Page 33 H Configuration
- Page 36 HDB Configuration
- Page 39 HJ Configuration
- Page 42 HJDB Configuration
- Page 45 HJFJ Configuration
- Page 50 FJh Configuration
- Page 53 FJhDB Configuration
- Page 57 LJ Configuration
- Page 61 LJDB Configuration

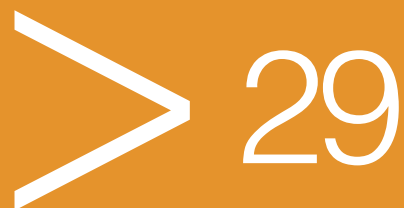

**Boom combination**

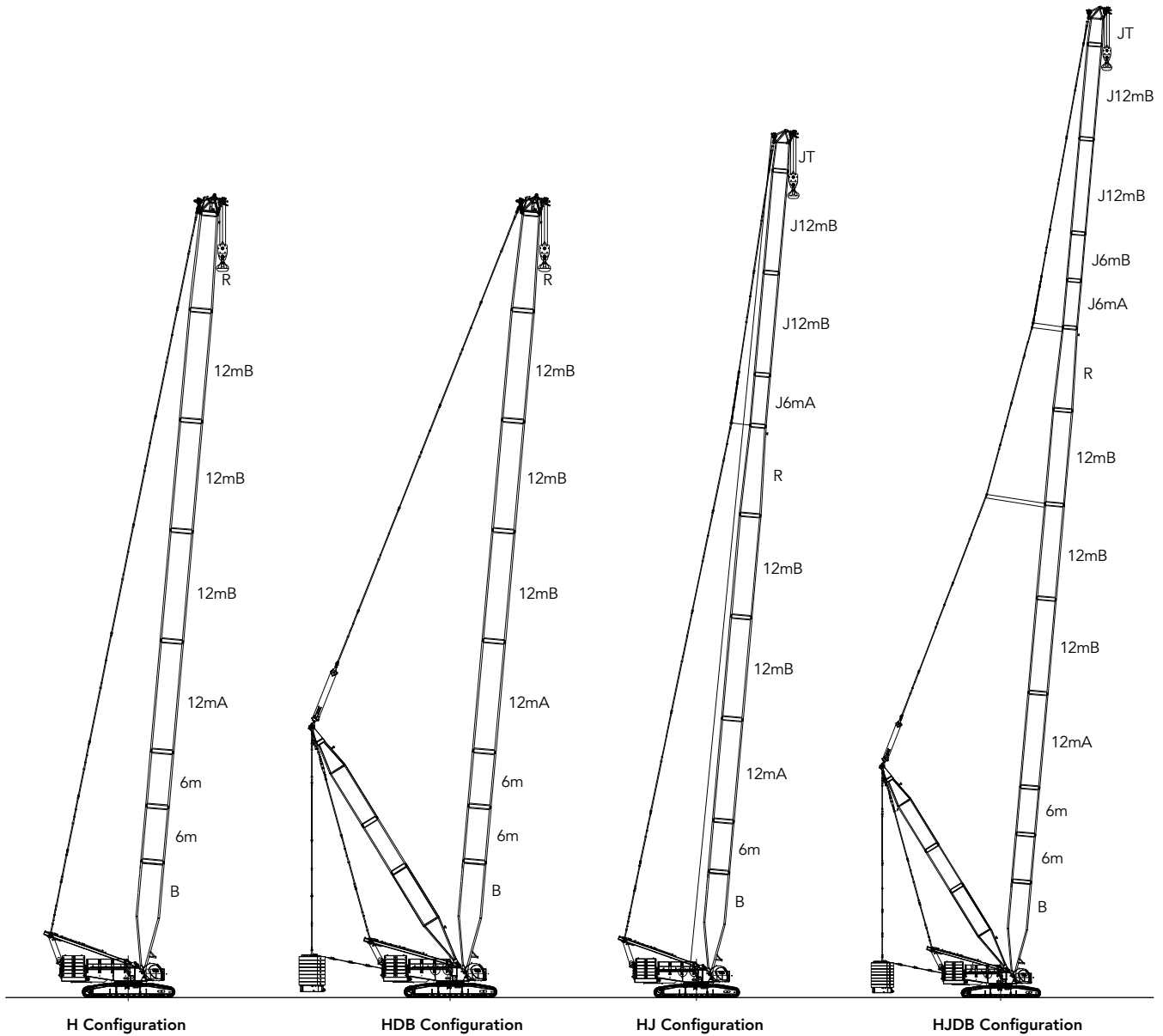

Configuration	Boom Combination	Boom Length
H	Boom	78.7ft~275.6ft(24m~84m)
HDB	Boom+ superlift mast+ superlift counterweight	118.1ft~275.6ft(36m~84m)
HJ	Mixed boom	147.6ft~324.8ft(45m~99m)
HJDB	Mixed boom+ superlift mast+ superlift counterweight	226.4ft~403.5ft(69m~123m)

Note: The schematics above are reference for loading only.

**Boom combination**

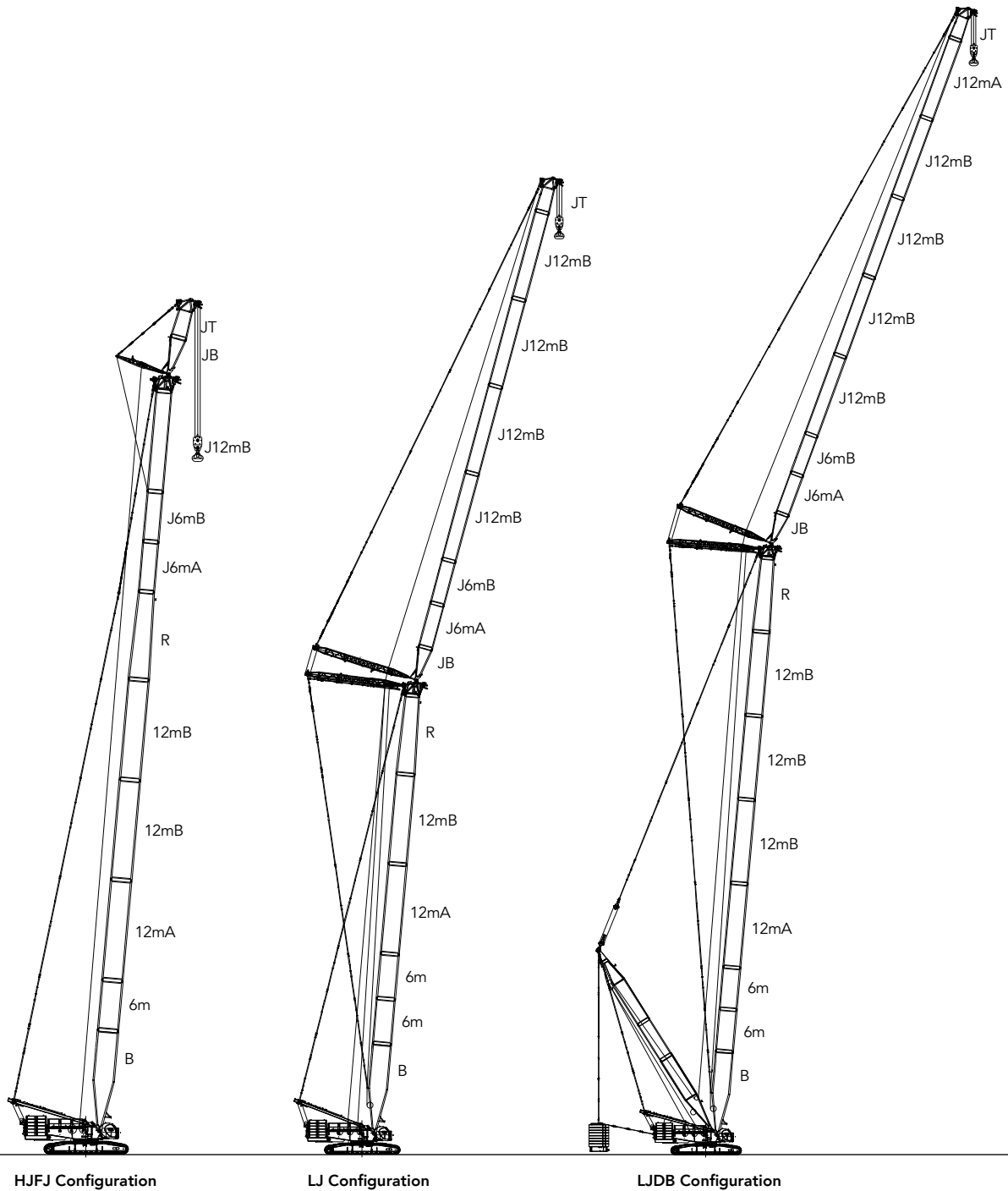

Configuration	Boom Combination	Boom Length
HJFJ	Mixed boom+ fixed jib	(236.2ft~295.3ft)+29.5ft (72m~90m)+9m
LJ	Boom+luffing jib	(118.1ft~196.9ft)+(68.9ft~226.4ft) (36m~60m)+(21m~69m)
LJDB	Boom + luffing jib +superlift mast+ superlift counterweight	(118.1ft~275.6ft)+(68.9ft~265.7ft) (36m~84m)+(21m~81m)

Note: The schematics above are reference for loading only.

**Boom combination**

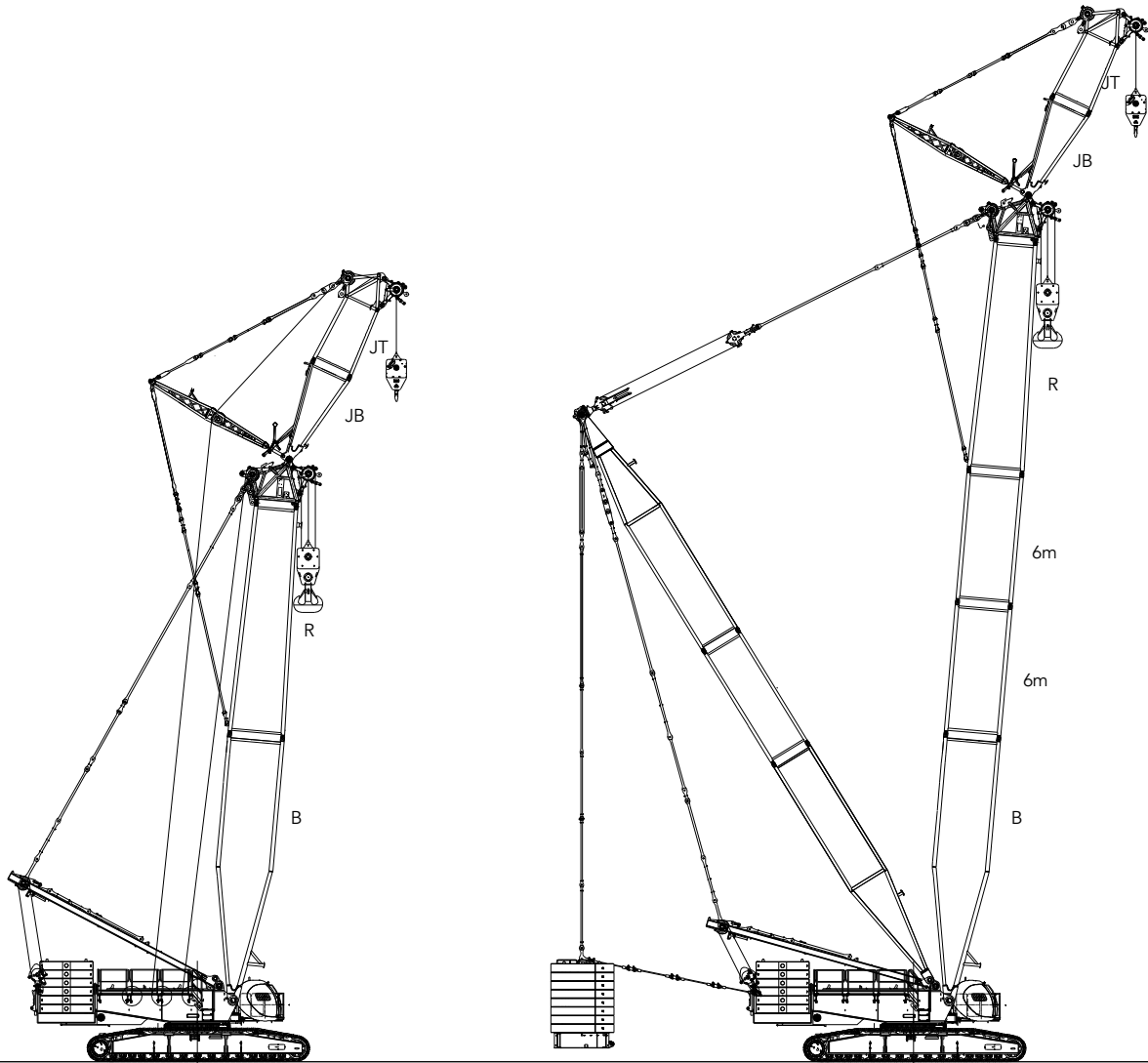

FJh Configuration

FJhDB Configuration

Configuration	Boom Combination	Boom Length
FJh	Boom+short heavy fixed jib	78.7ft+29.5ft(24m+9m)
FJhDB	Boom+short heavy fixed jib + superlift mast+ superlift counterweight	118.1ft+29.5ft(36m+9m)

Note: The schematics above are reference for loading only.



## Boom Combination in H

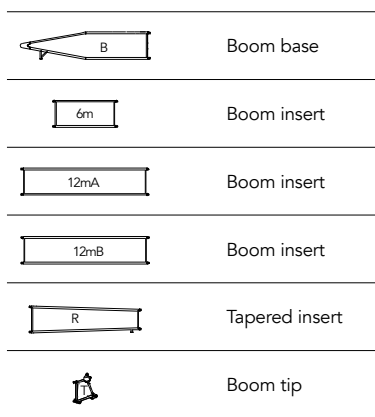
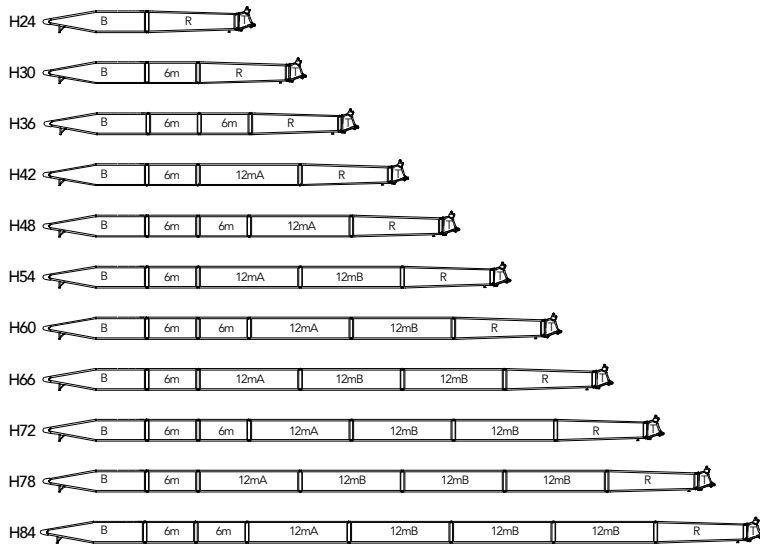

Note: The 78.7ft(24m) basic boom consists of 39.4ft(12m) boom base, 34.4ft(10.5m) tapered insert and 4.9ft(1.5m) boom tip.

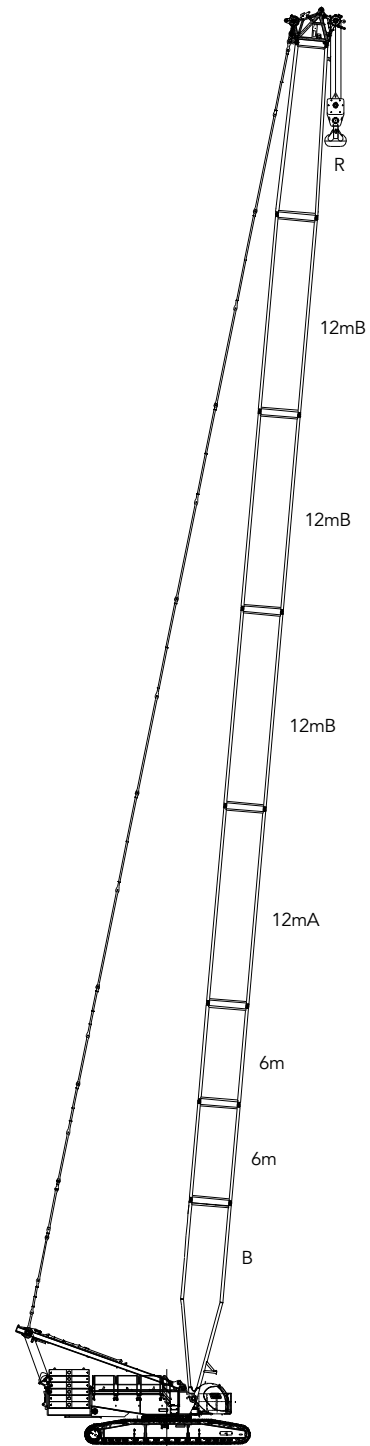

**H Configuration**  
78.7ft~275.6ft (24m~84m)

## Working Radius in H

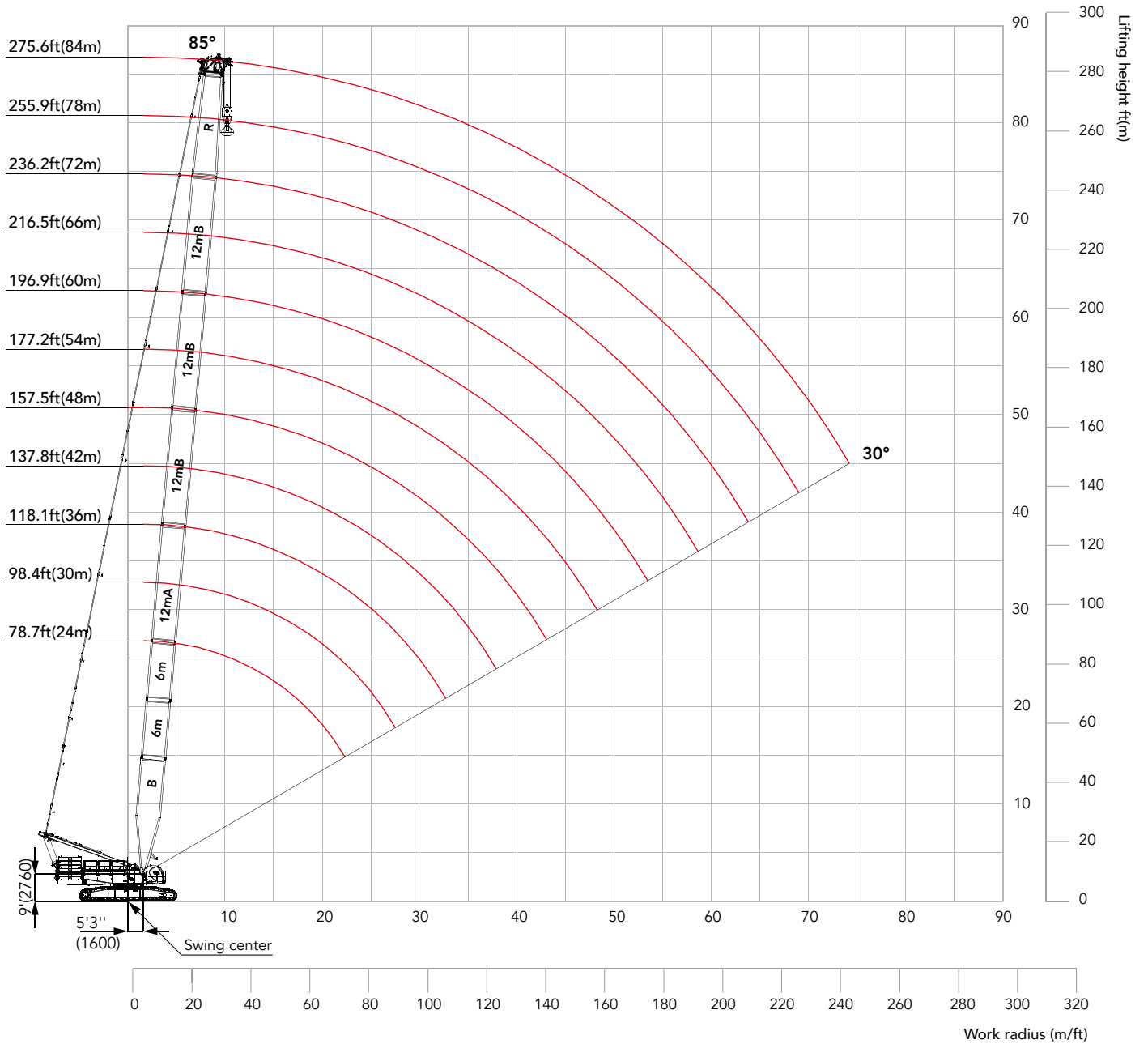

Unit:klb

## Load Chart of H

**Note:**

- 1.The rated load in the load chart is calculated complying with ASME B30.5;
- 2.The working radius is the horizontal distance from the load center to the swing center;
- 3.The actual lifting capacity must subtract the weight of hooks and other riggings from the rated capacity in the load chart;
- 4.The load value is calculated when the object is hung freely,without considering the influence of wind on the load, ground conditions and slope, operation speed and the influence of any other negative factors over safe operation. Therefore, the operator bears the responsibility of making a judgment and decreasing the load and lowering speed;
- 5.All ratings are calculated when the machine is parking on firm and level ground with less than 1% gradient.

H configuration load chart													
Boom length 78.7~275.6ft, Rear counterweight 330,687lb, Carbody counterweight 88,183lb													
Radius (ft)	78.7	98.4	118.1	137.8	157.5	177.2	196.9	216.5	236.2	255.9	275.6	Radius (ft)	
19.7	881.8											19.7	
25.0	774.9	751.3										25.0	
30.0	627.9	593.2	559.2	529.0	501.0							30.0	
35.0	517.2	490.8	465.8	443.7	422.4	404.1						35.0	
40.0	434.2	416.3	397.0	379.8	364.6	349.6	334.6	321.6	308.6			40.0	
45.0	363.6	360.8	346.6	332.8	319.3	307.6	296.0	284.6	273.3			45.0	
50.0	312.2	312.2	307.2	295.3	283.5	273.8	264.2	254.5	244.8	236.0	228.0	50.0	
55.0	271.9	271.9	271.1	264.3	254.1	245.3	237.4	229.2	220.9	212.9	206.4	55.0	
60.0	239.8	239.8	237.8	237.7	229.8	221.3	214.8	207.9	200.6	194.1	187.1	60.0	
65.0	213.9	214.1	213.1	212.5	209.3	202.7	195.9	189.6	183.1	177.1	170.8	65.0	
70.0	192.9	193.3	192.4	191.7	189.8	186.1	179.7	174.1	168.1	162.8	156.9	70.0	
75.0		175.3	174.5	173.7	172.3	170.6	165.4	160.4	154.8	150.0	144.5	75.0	
80.0		159.7	159.0	158.2	156.8	156.2	152.7	148.2	143.0	138.5	133.5	80.0	
85.0		146.3	145.6	144.9	143.4	142.7	141.1	137.3	132.4	128.2	123.6	85.0	
90.0		134.9	134.4	133.7	132.2	131.5	130.0	128.0	123.3	119.4	114.8	90.0	
95.0			124.2	123.6	122.1	121.5	119.8	118.7	114.9	111.3	106.8	95.0	
100.0			115.1	114.5	113.1	112.4	110.7	109.8	107.2	103.8	99.5	100.0	
105.0				106.4	104.9	104.2	102.7	101.6	100.0	96.9	93.0	105.0	
110.0				99.4	97.8	97.2	95.6	94.5	92.8	90.9	87.1	110.0	
115.0				92.8	91.3	90.8	89.1	88.0	86.3	85.0	81.6	115.0	
120.0				86.7	85.4	84.9	83.2	82.1	80.4	79.2	76.4	120.0	
130.0					75.0	74.6	72.8	71.9	70.2	68.8	67.0	130.0	
140.0						66.0	64.4	63.4	61.6	60.3	58.5	140.0	
150.0						58.5	56.9	55.8	54.0	52.8	51.0	150.0	
160.0							50.3	49.2	47.5	46.4	44.4	160.0	
170.0							44.4	43.5	41.7	40.6	38.7	170.0	
180.0								38.6	36.8	35.7	33.7	180.0	
190.0									32.4	31.3	29.3	190.0	
200.0										28.3	27.2	25.2	200.0
210.0											23.5	21.5	210.0
220.0											20.3	18.4	220.0
230.0												15.4	230.0
236.2												13.6	236.2

## Boom Combination in HDB

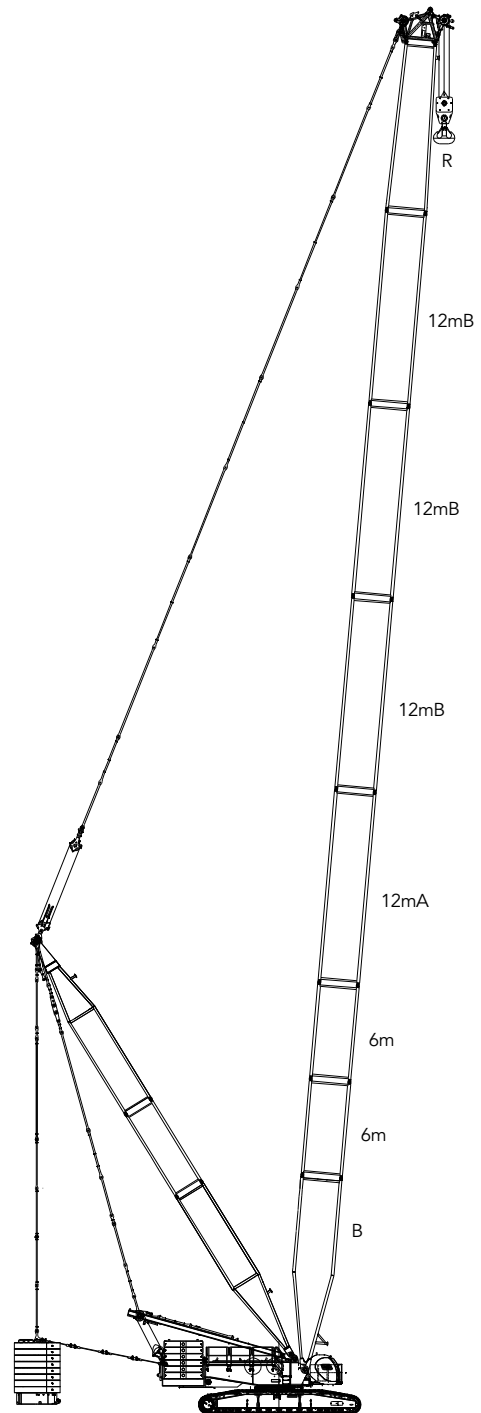
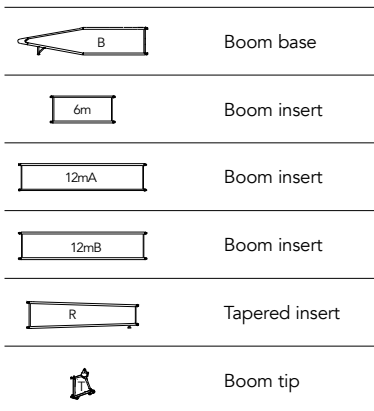
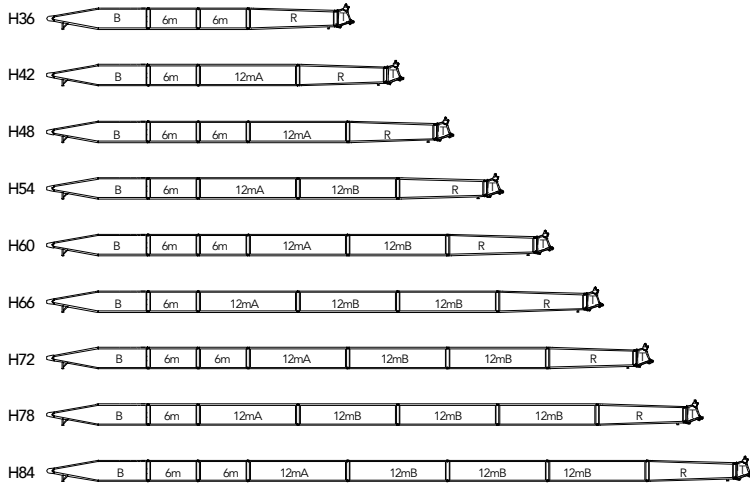

**HDB Configuration**  
118.1ft-275.6ft (36m-84m)

## Working Radius in HDB

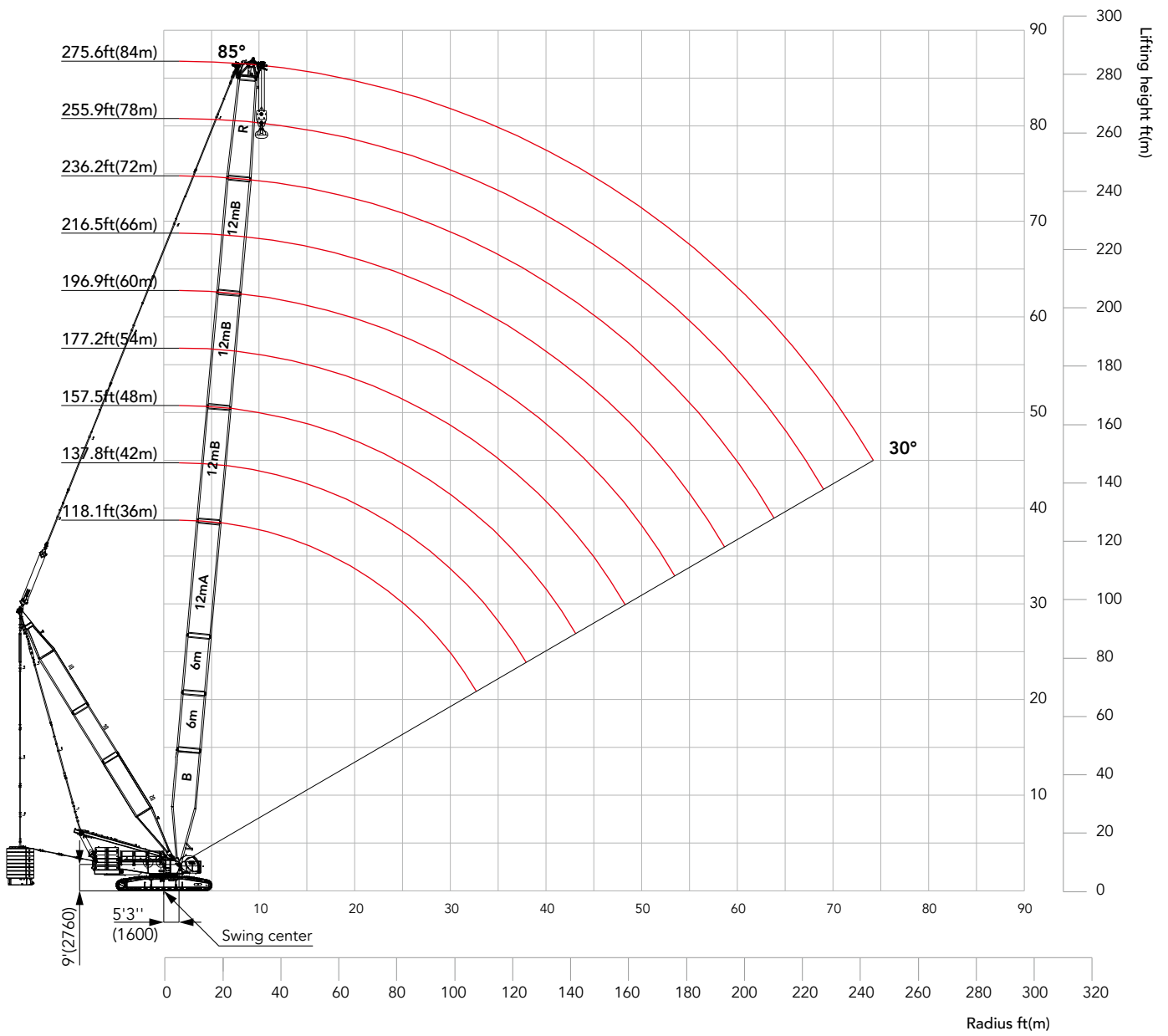

## Load Chart of HDB

### Note:

- 1.The rated load in the load chart is calculated complying with ASME B30.5;
- 2.The working radius is the horizontal distance from the load center to the swing center;
- 3.The actual lifting capacity must subtract the weight of hooks and other riggings from the rated capacity in the load chart;
- 4.The load value is calculated when the object is hung freely,without considering the influence of wind on the load, ground conditions and slope, operation speed and the influence of any other negative factors over safe operation. Therefore, the operator bears the responsibility of making a judgment and decreasing the load and lowering speed;
- 5.All ratings are calculated when the machine is parking on firm and level ground with less than 1% gradient;
- 6.See the Operation Manual for the complete load charts of HDB Configurations.

### HDB configuration load chart

Boom length 118.1~275.6ft, Superlift radius 49.2ft, Superlift counterweight 462,962lb, Rear counterweight 330,687lb, Carbody counterweight 88,183lb										
Radius(ft)	118.1	137.8	157.5	177.2	196.9	216.5	236.2	255.9	275.6	Radius(ft)
23.0	881.8*	881.8*								23.0
25.0	881.8*	881.8*								25.0
30.0	881.8*	881.8*	881.8*	769.4*	725.3*	615.0*				30.0
35.0	881.8	881.8	881.8	769.4*	725.3*	615.0*	541.6*	447.5*		35.0
40.0	878.8	878.6	878.6	769.4	725.3	615.0*	542.5*	447.7*	388.0*	40.0
45.0	855.3	853.4	853.4	769.4	725.3	615.0*	544.2*	449.4*	388.0*	45.0
50.0	778.5	777.7	777.7	747.5	725.3	631.4	543.1*	449.7*	389.3*	50.0
55.0	700.4	699.6	699.6	700.4	695.0	642.3	542.3	448.9*	389.3*	55.0
60.0	635.7	633.5	633.5	635.1	635.1	633.2	542.3	447.5	388.0*	60.0
65.0	582.0	579.8	579.8	578.0	578.0	577.8	542.3	447.5	388.0*	65.0
70.0	537.1	534.9	534.9	534.1	531.2	531.2	520.2	447.5	386.5	70.0
75.0	497.2	495.0	495.0	495.9	492.5	489.6	488.4	446.5	386.7	75.0
80.0	461.9	459.7	459.7	461.9	459.7	454.4	452.7	440.2	387.5	80.0
85.0	431.7	429.5	429.5	431.7	429.5	429.2	420.8	420.0	385.9	85.0
90.0	404.6	404.0	404.0	404.6	404.0	402.4	399.9	393.6	382.6	90.0
95.0	380.9	379.8	379.8	379.8	379.8	378.7	377.6	373.0	367.7	95.0
100.0	359.6	357.4	357.4	357.9	357.4	357.4	355.7	355.2	348.5	100.0
105.0		337.2	337.2	339.4	337.2	337.2	337.2	335.0	335.0	105.0
110.0		320.4	320.4	320.9	320.4	320.4	318.7	318.2	316.5	110.0
115.0		304.8	304.8	304.8	304.8	304.8	302.6	302.6	300.4	115.0
120.0		290.3	290.3	290.3	289.7	289.7	288.1	287.5	285.9	120.0
130.0			263.4	263.4	263.0	263.0	261.2	260.8	259.0	130.0
140.0				241.0	241.0	241.0	238.7	238.7	238.0	140.0
150.0				222.1	221.9	221.8	220.0	219.8	219.1	150.0
160.0					205.3	205.1	204.0	203.4	201.8	160.0
170.0					190.0	190.0	188.9	188.3	186.7	170.0
180.0						176.8	175.7	175.0	173.6	180.0
190.0							163.7	163.1	161.8	190.0
200.0							152.9	152.3	150.9	200.0
210.0								142.3	141.0	210.0
220.0								133.6	132.3	220.0
230.0									124.1	230.0
236.2									119.2	236.2

Note:For values marked with "\*\*", the superlift counterweight shall not leave the ground.

## Boom Combination of HJ

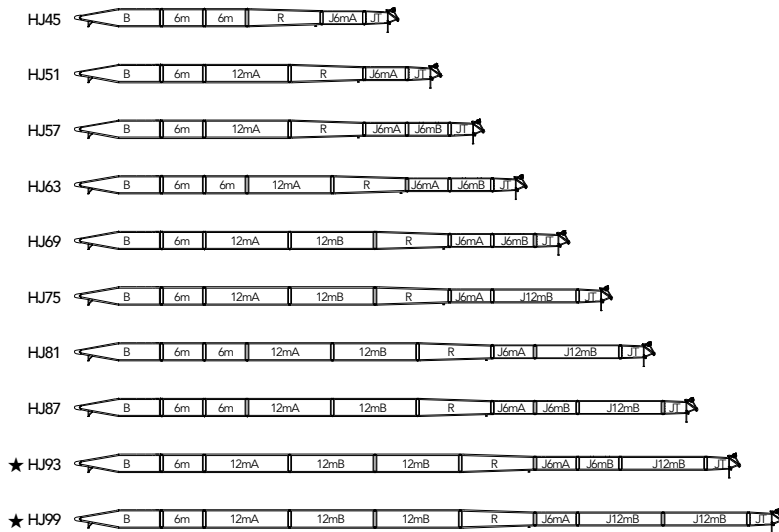

	Boom base
	Boom insert
	Boom insert
	Boom insert
	Tapered insert
	Boom tip
	Jib base
	Jib top
	Jib insert
	Jib insert
	Jib insert
	Jib insert

**Note:**

1. The 39.4ft(12m) boom base, 34.4ft(10.5m) tapered insert, 19.8ft(6m) tapered jib insert, 14.8ft(4.5m) jib top are must.
2. For combinations marked with " ★ ", the mid-point suspension cable must be used, otherwise, the boom may break.

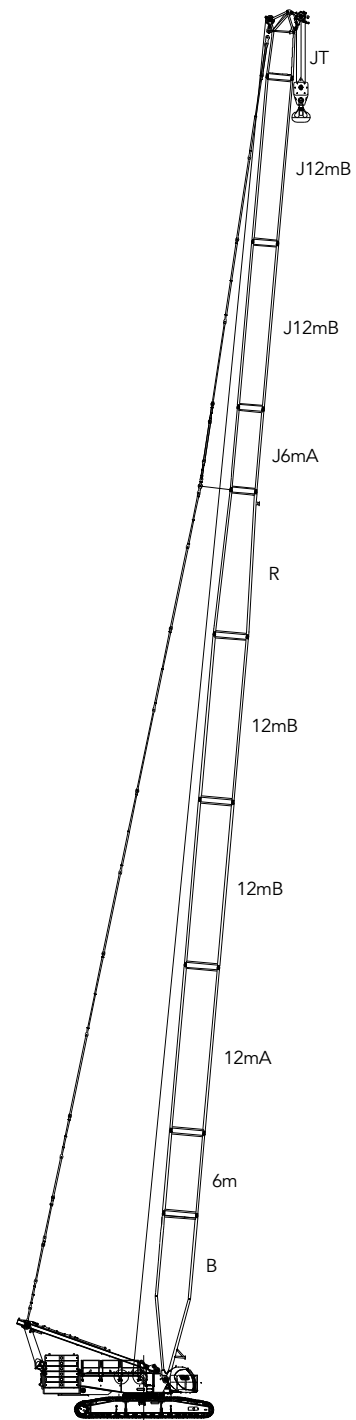

**HJ Configuration**  
147.6ft~324.8ft  
(45m~99m)





Unit:klb

## Load Chart of HJ

**Note:**

1. The rated load in the load chart is calculated complying with ASME B30.5;
2. The working radius is the horizontal distance from the load center to the swing center;
3. The actual lifting capacity must subtract the weight of hooks and other riggings from the rated capacity in the load chart;
4. The load value is calculated when the object is hung freely, without considering the influence of wind on the load, ground conditions and slope, operation speed and the influence of any other negative factors over safe operation. Therefore, the operator bears the responsibility of making a judgment and decreasing the load and lowering speed;
5. All ratings are calculated when the machine is parking on firm and level ground with less than 1% gradient.

HJ configuration load chart											
Boom length 147.6-324.8 ft,Rear counterweight 330,687lb, Carbody counterweight 88,183lb											
Radius(ft)	147.6	167.3	187.0	206.7	226.4	246.1	265.7	285.4	305.1	324.8	Radius(ft)
23.0	432.1										23.0
25.0	433.4										25.0
30.0	434.9	432.4	423.6	415.4	409.0						30.0
35.0	428.4	413.6	400.4	382.8	368.1	354.1	338.0				35.0
40.0	377.8	362.6	349.6	334.6	321.6	311.0	298.0	263.2	262.4	222.0	40.0
45.0	332.5	318.9	307.6	296.0	284.6	277.4	266.0	253.2	245.6	216.8	45.0
50.0	295.3	284.8	275.2	265.5	255.9	249.2	239.6	232.1	224.6	210.6	50.0
55.0	264.3	256.3	248.3	239.5	231.7	225.4	217.3	210.9	204.2	198.5	55.0
60.0	238.4	232.1	225.6	217.0	210.9	205.3	197.9	192.5	186.2	181.2	60.0
65.0	216.9	212.1	206.3	199.0	193.1	188.1	179.3	176.5	170.9	166.5	65.0
70.0	196.6	194.3	189.9	183.4	177.9	173.5	163.0	162.8	157.7	153.6	70.0
75.0	178.7	177.5	175.2	169.5	164.4	160.0	148.7	150.6	145.8	142.1	75.0
80.0	163.2	162.0	161.5	157.0	152.3	147.2	136.2	139.7	135.1	131.9	80.0
85.0	149.8	148.7	148.2	145.9	141.7	134.7	125.0	129.9	125.7	122.6	85.0
90.0	138.6	137.5	136.9	135.0	132.4	123.9	114.8	121.3	117.4	114.5	90.0
95.0	128.5	127.4	126.8	125.0	123.4	114.3	105.4	113.5	109.8	107.1	95.0
100.0	119.5	118.4	117.8	116.0	114.9	105.7	96.8	106.4	102.9	100.3	100.0
105.0	111.5	110.2	109.7	108.0	106.9	97.6	89.4	99.8	96.5	94.1	105.0
110.0	104.4	103.3	102.7	100.9	99.8	90.4	82.7	93.9	90.8	88.4	110.0
115.0	98.0	96.9	96.2	94.4	93.3	84.1	76.5	88.5	85.4	83.1	115.0
120.0	92.0	90.9	90.2	88.5	87.4	78.1	70.4	83.5	80.4	78.3	120.0
130.0	81.6	80.5	79.9	78.1	77.0	67.1	59.4	73.9	71.5	69.7	130.0
140.0		72.0	71.4	69.7	68.6	57.6	50.5	65.3	63.7	62.4	140.0
150.0			64.0	62.2	61.1	49.2	42.5	57.9	56.5	55.6	150.0
160.0				55.6	54.5	41.8	35.4	51.4	49.9	49.2	160.0
170.0				49.9	48.8	35.4	29.0	45.7	44.2	43.5	170.0
180.0				44.8	43.9	29.6	23.9	40.8	39.2	38.6	180.0
190.0					39.4	24.6	18.8	36.3	34.8	34.2	190.0
200.0						19.9	14.1	32.3	30.8	30.3	200.0
210.0							10.1	28.6	27.3	26.6	210.0
220.0							6.0	25.4	24.1	23.4	220.0
230.0								22.4	21.1	20.5	230.0
240.0								19.7	18.4	17.7	240.0
250.0									15.9	15.2	250.0
260.0									13.5	13.1	260.0
270.0										10.9	270.0
275.5										9.7	275.5

## Boom Combination in HJDB

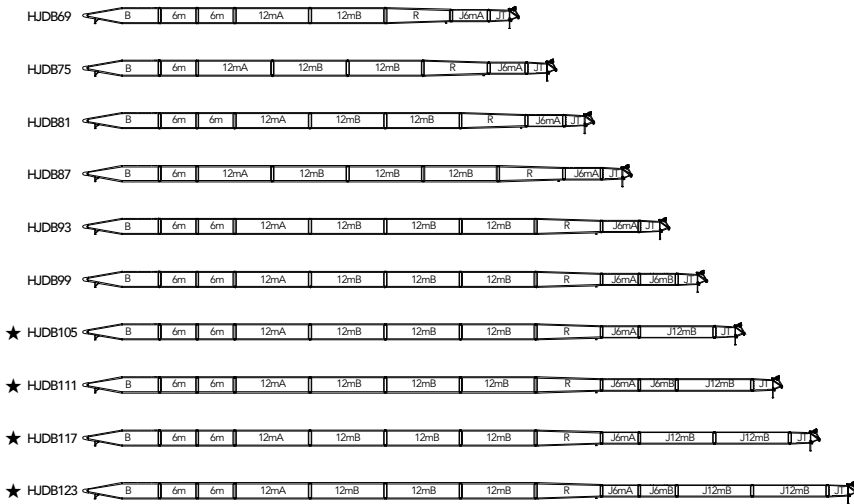

	Boom base
	Boom insert
	Boom insert
	Boom insert
	Tapered insert
	Jib top
	Jib insert
	Jib insert
	Jib insert
	Jib insert

- Note:
1. The 39.4ft(12m) boom base, 34.4ft(10.5m) tapered insert, 19.7ft(6m) luffing jib insert A and 14.8ft(4.5m) jib top are must.
  2. For combinations marked with " ★ ", the mid-suspension cable must be used, otherwise, the boom system may break.

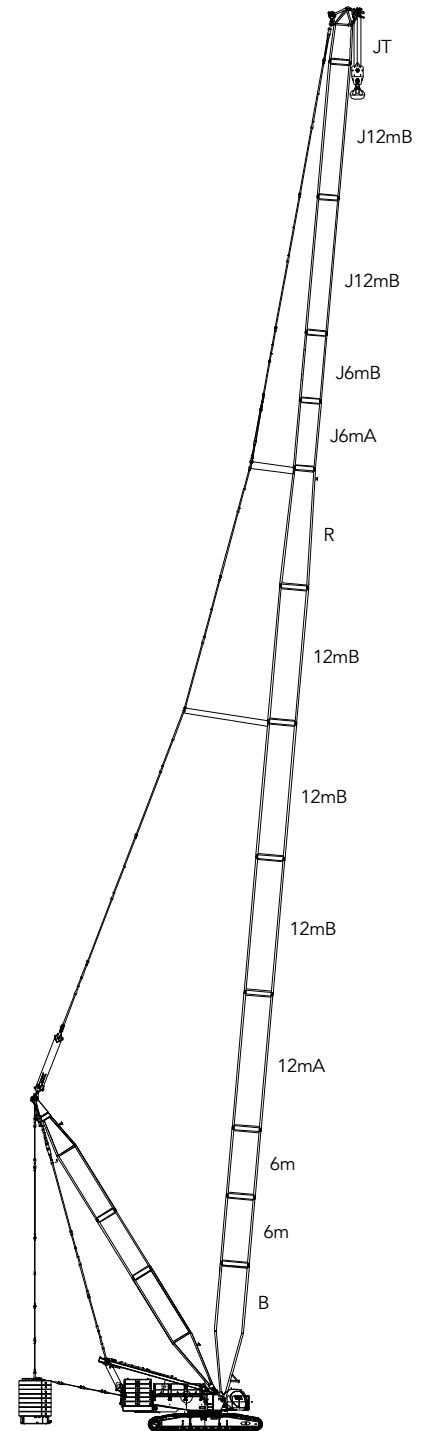

**HJDB Configuration**  
226.4ft~403.5ft  
(69m~123m)



## Load Chart of HJDB

Note:

- 1.The rated load in the load chart is calculated complying with ASME B30.5;
- 2.The working radius is the horizontal distance from the load center to the swing center;
- 3.The actual lifting capacity must subtract the weight of hooks and other riggings from the rated capacity in the load chart;
- 4.The load value is calculated when the object is hung freely,without considering the influence of wind on the load, ground conditions and slope, operation speed and the influence of any other negative factors over safe operation. Therefore, the operator bears the responsibility of making a judgment and decreasing the load and lowering speed;
- 5.All ratings are calculated when the machine is parking on firm and level ground with less than 1% gradient;
- 6.See the Operation Manual for the complete load charts of HJDB Configuration.

### HJDB configuration load chart

Boom length 226.4-403.5ft, Superlift radius 49.2ft, Superlift counterweight 220,459lb,  
Rear counterweight 330,687lb, Carbody counterweight 88,183lb

Radius (ft)	226.4	246.1	265.7	285.4	305.1	324.8	344.5	364.2	383.9	403.5	Radius (ft)
29.6	418.8*										29.6
35.0	418.8	412.2	405.6								35.0
40.0	419.3	412.8	408.0	354.9	312.8	269.1*	231.4*				40.0
45.0	422.6	417.9	409.7	354.9	311.1	270.8*	231.4*				45.0
50.0	424.6	417.5	410.0	354.9	310.8	271.1	231.4*	201.8*	176.0*	152.7*	50.0
55.0	423.8	417.5	411.7	354.9	310.8	270.3	231.4	202.0*	175.8*	151.8*	55.0
60.0	413.7	411.8	407.8	354.9	310.8	268.9	231.1	202.1	175.6	150.8*	60.0
65.0	375.1	374.9	372.5	354.9	310.8	268.9	229.4	202.1	175.1	149.8*	65.0
70.0	343.8	343.8	341.6	335.7	310.8	268.9	229.2	202.1	174.0	148.6	70.0
75.0	316.4	316.4	314.2	312.0	302.3	268.9	229.2	199.6	170.4	145.8	75.0
80.0	292.5	292.1	289.9	288.1	285.9	268.1	229.2	195.0	165.2	141.6	80.0
85.0	272.3	270.2	268.0	267.9	265.7	264.7	229.2	189.7	160.5	136.7	85.0
90.0	266.4	253.1	250.9	249.3	247.1	247.1	229.2	184.4	155.8	133.1	90.0
95.0	254.0	244.8	235.2	233.0	230.8	230.8	225.0	179.2	151.1	129.3	95.0
100.0	238.2	238.2	224.3	218.7	216.5	216.3	216.2	174.3	146.7	125.2	100.0
105.0	224.8	224.8	222.6	206.3	204.3	203.4	203.0	170.1	142.8	121.2	105.0
110.0	212.9	212.4	210.3	205.6	192.5	191.6	191.2	165.8	138.9	117.8	110.0
115.0	201.6	200.9	199.0	197.8	188.9	180.8	180.4	161.5	135.5	114.8	115.0
120.0	193.7	190.2	188.4	187.2	185.2	174.6	170.5	157.3	132.1	111.8	120.0
130.0	181.4	171.6	169.7	168.6	166.6	165.7	163.1	149.8	125.3	105.8	130.0
140.0	165.8	161.7	159.5	153.1	151.2	150.3	149.9	142.5	119.8	101.0	140.0
150.0	151.6	150.6	148.4	142.6	137.5	136.6	136.1	133.4	114.5	96.4	150.0
160.0	138.8	138.2	136.1	134.6	126.6	124.4	124.0	122.9	109.6	92.0	160.0
170.0	127.2	126.7	125.4	123.8	121.1	113.7	113.5	112.4	105.4	88.1	170.0
180.0	117.2	116.9	115.6	114.7	112.2	108.9	108.1	103.2	100.8	84.3	180.0
190.0	108.2	107.9	106.7	105.9	103.9	102.4	101.4	97.2	94.3	81.3	190.0
200.0		99.7	98.6	97.7	96.2	94.8	93.9	92.1	87.9	78.6	200.0
210.0			91.2	90.3	89.0	87.9	87.0	85.3	84.2	75.8	210.0
220.0			84.7	83.9	82.4	81.7	81.0	79.4	78.1	73.6	220.0
230.0			78.6	77.9	76.4	75.8	75.4	73.8	72.6	70.1	230.0
240.0				72.3	70.7	70.3	70.1	68.7	67.6	65.9	240.0
250.0					65.6	65.1	65.1	64.0	62.9	61.2	250.0
260.0					60.9	60.4	60.4	59.5	58.7	57.0	260.0
270.0						56.0	56.0	55.1	54.7	53.0	270.0
280.0							51.8	50.9	50.7	49.3	280.0
290.0							48.0	47.1	46.9	45.8	290.0
300.0							44.5	43.6	43.4	42.3	300.0
310.0								40.3	40.1	39.0	310.0
320.0									37.0	35.9	320.0
330.0										32.9	330.0
340.0										30.3	340.0
350.0										27.6	350.0
354.3										26.4	354.3

Note:For values marked with "\*\*", the superlift counterweight shall not leave the ground.

## Boom Combination in HJFJ

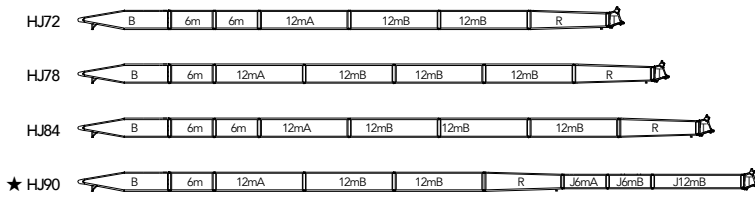

	Boom base
	Boom insert
	Boom insert
	Boom insert
	Tapered insert
	Boom tip
	Jib base
	Jib top
	Jib insert
	Jib insert
	Jib insert

**Note:**

- 1.The 39.4ft(12m) boom base and 34.4ft(10.5m) tapered insert are must. For jib combination, the 14.8ft(4.5m) jib base, 19.7ft(6m) luffing jib insert A, and 14.8ft(4.5m) jib top are must.
- 2.For combinations marked with " ★ ", the mid-point suspension cable must be used, otherwise, the boom system may break.

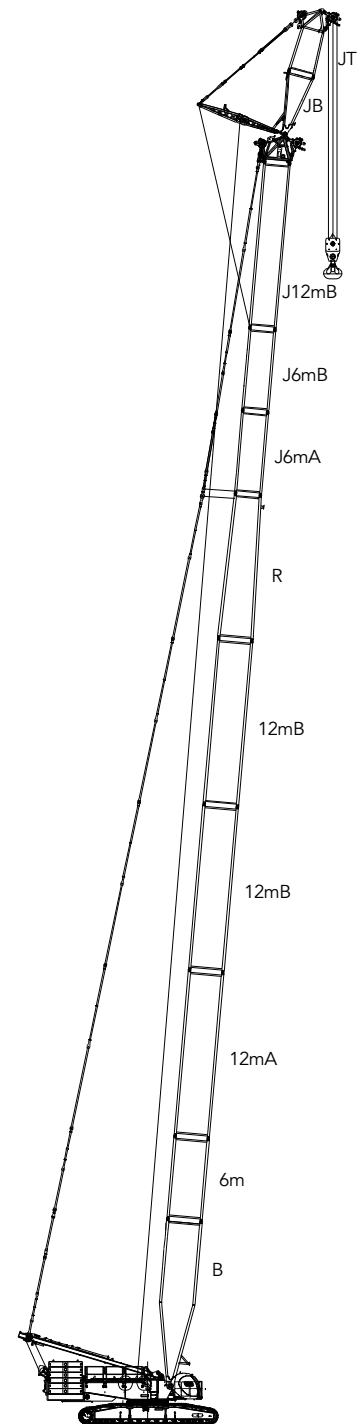

**HJFJ onfiguration**  
**(236.2ft~295.3ft)+29.5ft**  
**(72m~90m)+9m**



Unit:klb

## Load Chart of HJFJ

**Note:**

- 1.The rated load in the load chart is calculated complying with ASME B30.5;
- 2.The working radius is the horizontal distance from the load center to the swing center;
- 3.The actual lifting capacity must subtract the weight of hooks and other riggings from the rated capacity in the load chart;
- 4.The load value is calculated when the object is hung freely,without considering the influence of wind on the load, ground conditions and slope, operation speed and the influence of any other negative factors over safe operation. Therefore, the operator bears the responsibility of making a judgment and decreasing the load and lowering speed;
- 5.All ratings are calculated when the machine is parking on firm and level ground with less than 1% gradient;
- 6.See the Operation Manual for the complete load charts of HJFJ Configuration.

### HJFJ configuration load chart 1/3

Boom length 236.2~275.5ft, Jib length 29.5ft, Rear counterweight 330,687lb, Carbody counterweight 88,183lb  
Boom to jib angle 10°

Radius (ft)	236.2	255.9	275.6	Radius (ft)
46.0	251.3	242.5	233.6	46.0
50.0	230.9	222.9	214.8	50.0
55.0	208.0	200.8	193.5	55.0
60.0	187.9	181.4	174.8	60.0
65.0	170.7	164.9	158.9	65.0
70.0	156.1	150.8	145.3	70.0
75.0	143.0	138.2	133.1	75.0
80.0	131.4	126.8	122.1	80.0
85.0	121.0	116.7	112.3	85.0
90.0	112.0	107.9	103.7	90.0
95.0	103.7	99.8	95.7	95.0
100.0	96.1	92.4	88.4	100.0
105.0	89.2	85.7	81.7	105.0
110.0	83.0	79.6	75.8	110.0
115.0	77.3	74.1	70.3	115.0
120.0	71.9	68.8	65.2	120.0
130.0	62.4	59.5	56.1	130.0
140.0	54.0	51.6	48.3	140.0
150.0	46.5	44.5	41.3	150.0
160.0	39.7	38.2	35.1	160.0
170.0	33.8	32.5	29.6	170.0
180.0	28.6	27.2	24.9	180.0
190.0	23.9	22.6	20.5	190.0
200.0	19.7	18.4	16.4	200.0
210.0	16.0	14.7	12.7	210.0
220.0	12.7	11.4	9.4	220.0
230.0	9.4	8.2	6.4	230.0
240.0		5.3	3.6	240.0
249.3		2.8	1.1	249.3

**Load Chart of HJFJ**

HJFJ configuration load chart 2/3				
Boom length 236.2~275.5ft, Jib length 29.5ft, Rear counterweight 330,687lb, Carbody counterweight 88,183lb Boom to jib angle 15°				
Radius (ft)	236.2	255.9	275.6	Radius (ft)
46.0	253.5	244.7		46.0
50.0	233.0	225.1		50.0
55.0	210.0	202.9	195.7	55.0
60.0	189.8	183.3	176.8	60.0
65.0	172.5	166.7	160.9	65.0
70.0	157.7	152.4	147.0	70.0
75.0	144.5	139.7	134.6	75.0
80.0	132.7	128.3	123.6	80.0
85.0	122.3	118.1	113.6	85.0
90.0	113.1	109.1	104.8	90.0
95.0	104.8	100.9	96.8	95.0
100.0	97.2	93.5	89.5	100.0
105.0	90.1	86.6	82.8	105.0
110.0	83.9	80.5	76.8	110.0
115.0	78.0	74.8	71.2	115.0
120.0	72.6	69.5	66.0	120.0
130.0	63.0	60.2	56.8	130.0
140.0	54.7	52.1	49.0	140.0
150.0	47.0	45.0	41.9	150.0
160.0	40.1	38.6	35.6	160.0
170.0	34.0	32.7	30.0	170.0
180.0	28.8	27.6	25.1	180.0
190.0	24.1	22.9	20.7	190.0
200.0	19.9	18.6	16.6	200.0
210.0	16.0	14.7	12.9	210.0
220.0	12.7	11.4	9.6	220.0
230.0	9.4	8.2	6.5	230.0
240.0		5.3	3.6	240.0
249.3		2.8	1.1	249.3



Unit:klb

## Load Chart of HJFJ

HJFJ configuration load chart 3/3				
Boom length 236.2~275.5ft, Jib length 29.5ft, Rear counterweight 330,687lb, Carbody counterweight 88,183lb Boom to jib angle 20°				
Radius (ft)	236.2	255.9	275.6	Radius (ft)
46.0	255.7			46.0
50.0	233.8			50.0
55.0	210.5	204.5	197.3	55.0
60.0	191.1	184.8	178.3	60.0
65.0	173.6	168.0	162.0	65.0
70.0	158.8	153.6	148.1	70.0
75.0	145.6	140.7	135.6	75.0
80.0	133.7	129.2	124.4	80.0
85.0	123.2	119.0	114.5	85.0
90.0	113.8	110.0	105.7	90.0
95.0	105.4	101.7	97.6	95.0
100.0	97.8	94.1	90.2	100.0
105.0	90.8	87.2	83.5	105.0
110.0	84.4	81.2	77.4	110.0
115.0	78.6	75.5	71.9	115.0
120.0	73.2	70.1	66.7	120.0
130.0	63.5	60.6	57.3	130.0
140.0	55.0	52.6	49.4	140.0
150.0	47.2	45.3	42.3	150.0
160.0	40.3	38.8	36.0	160.0
170.0	34.3	32.9	30.3	170.0
180.0	29.0	27.8	25.4	180.0
190.0	24.3	23.1	20.9	190.0
200.0	20.1	18.8	16.9	200.0
210.0	16.0	14.9	13.2	210.0
220.0	12.7	11.4	9.8	220.0
230.0	9.4	8.2	6.7	230.0
240.0		5.3	3.7	240.0
249.3		2.8	1.1	249.3

## Boom Combination in FJh

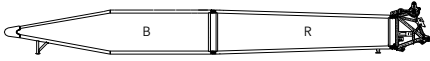

	Boom base
	Tapered insert
	Boom tip
	Jib base
	Jib top

**Note:**

The 78.7ft(24m) basic boom consists of 39.4ft(12m) boom base, 34.4ft(10.5m) tapered insert and 4.9ft(1.5m) boom tip. The 29.5ft(9m) jib combination of FJh Configuration is the same as that of HJFJ Configuration.

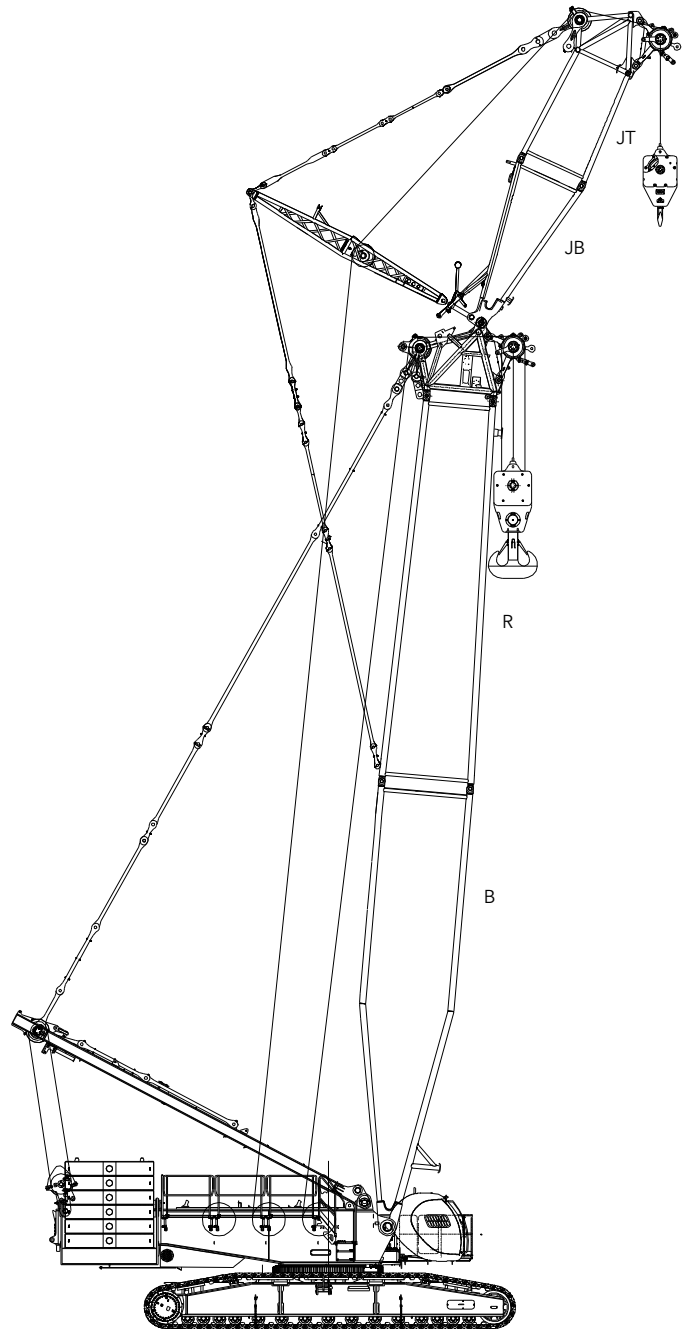

**FJh Configuration**  
78.7ft+29.5ft  
(24m+9m)

## Working Radius of FJh

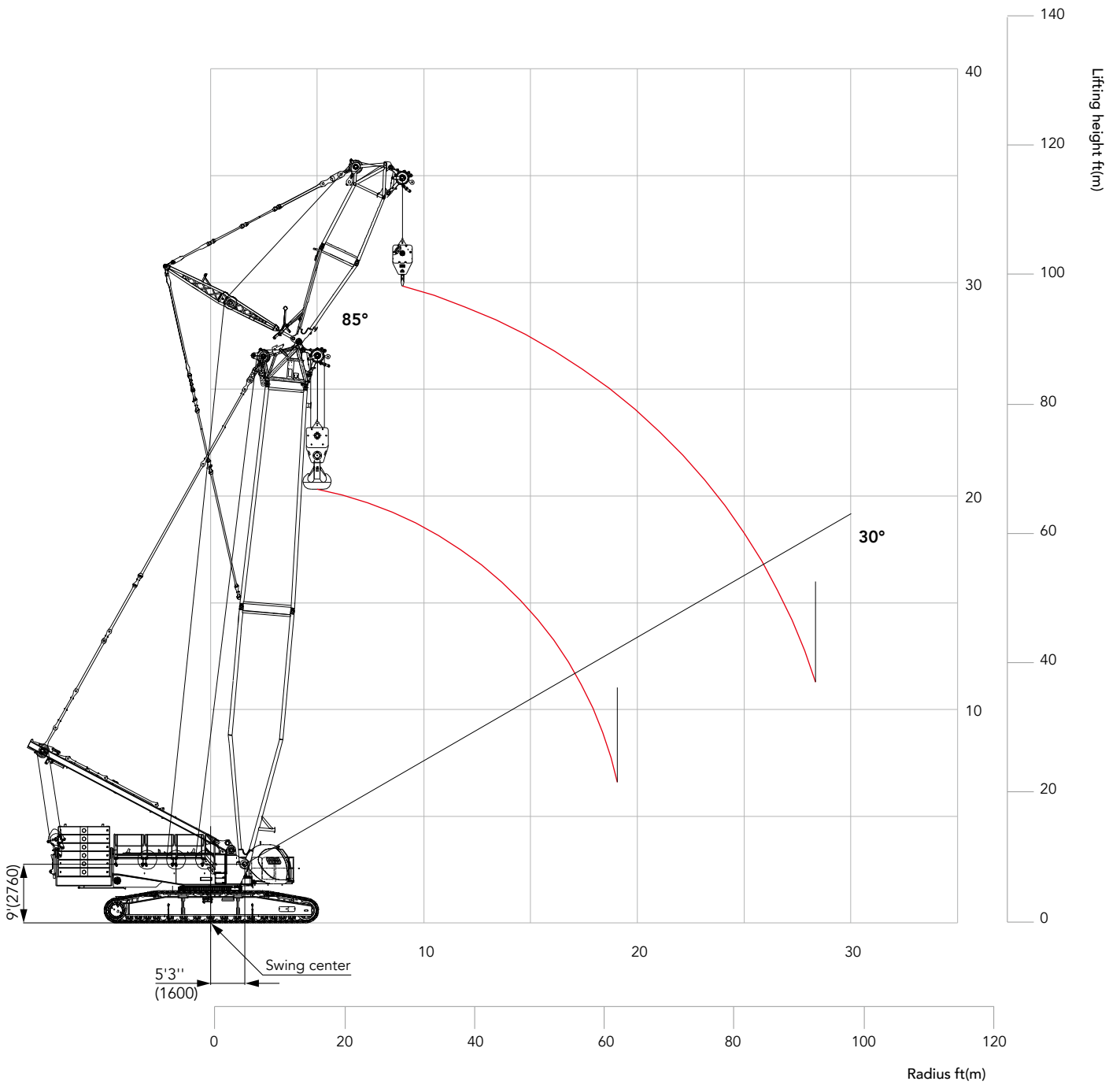

## Load Chart of FJh

### Note:

- 1.The rated load in the load chart is calculated complying with ASME B30.5;
- 2.The working radius is the horizontal distance from the load center to the swing center;
- 3.The actual lifting capacity must subtract the weight of hooks and other riggings from the rated capacity in the load chart;
- 4.The load value is calculated when the object is hung freely,without considering the influence of wind on the load, ground conditions and slope, operation speed and the influence of any other negative factors over safe operation. Therefore, the operator bears the responsibility of making a judgment and decreasing the load and lowering speed;
- 5.All ratings are calculated when the machine is parking on firm and level ground with less than 1% gradient;
- 6.See the Operation Manual for the complete load charts of FJh Configuration.

### FJh configuration load chart

Boom length 78.7~78.7ft, Jib length29.5ft, Boom to jib angle 20°, Rear counterweight 330,687lb, Carbody counterweight 88,183lb

Radius(ft)	Boom length(ft)		Radius(ft)
	78.7		
18.1	881.8		18.1
20.0	877.4		20.0
25.0	761.7		25.0
30.0	610.2		30.0
35.0	495.2		35.0
40.0	416.8		40.0
45.0	347.9		45.0
50.0	296.8		50.0
55.0	255.6		55.0
60.0	222.3		60.0
65.0	197.5		65.0
70.0	176.4		70.0
72.1	167.5		72.1

### FJh configuration load chart

Boom length 78.7~78.7ft, Jib length29.5ft, Boom to jib angle 20°, Rear counterweight 330,687lb, Carbody counterweight 88,183lb

Radius(ft)	Boom length(ft)		Radius(ft)
	29.5		
32.9	368.1		32.9
35.0	357.8		35.0
40.0	334.9		40.0
45.0	316.5		45.0
50.0	299.3		50.0
55.0	274.1		55.0
60.0	241.9		60.0
65.0	215.7		65.0
70.0	194.2		70.0
75.0	175.7		75.0
80.0	159.6		80.0
85.0	145.6		85.0
90.0	133.9		90.0
95.0	123.3		95.0
100.0	113.5		100.0
104.9	104.7		104.9

## Boom Combination in FJhDB

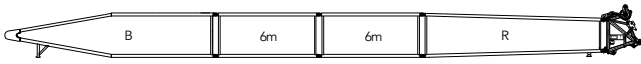

	Boom base
	Boom insert
	Tapered insert
	Boom tip
	Jib base
	Jib top

Note:  
The 78.7ft(24m) basic boom consists of 39.4ft(12m) boom base, 34.4ft(10.5m) tapered insert and 4.9ft(1.5m) boom tip. For jib combination, the 14.8ft(4.5m) jib base, and 14.8ft(4.5m) jib top are must.

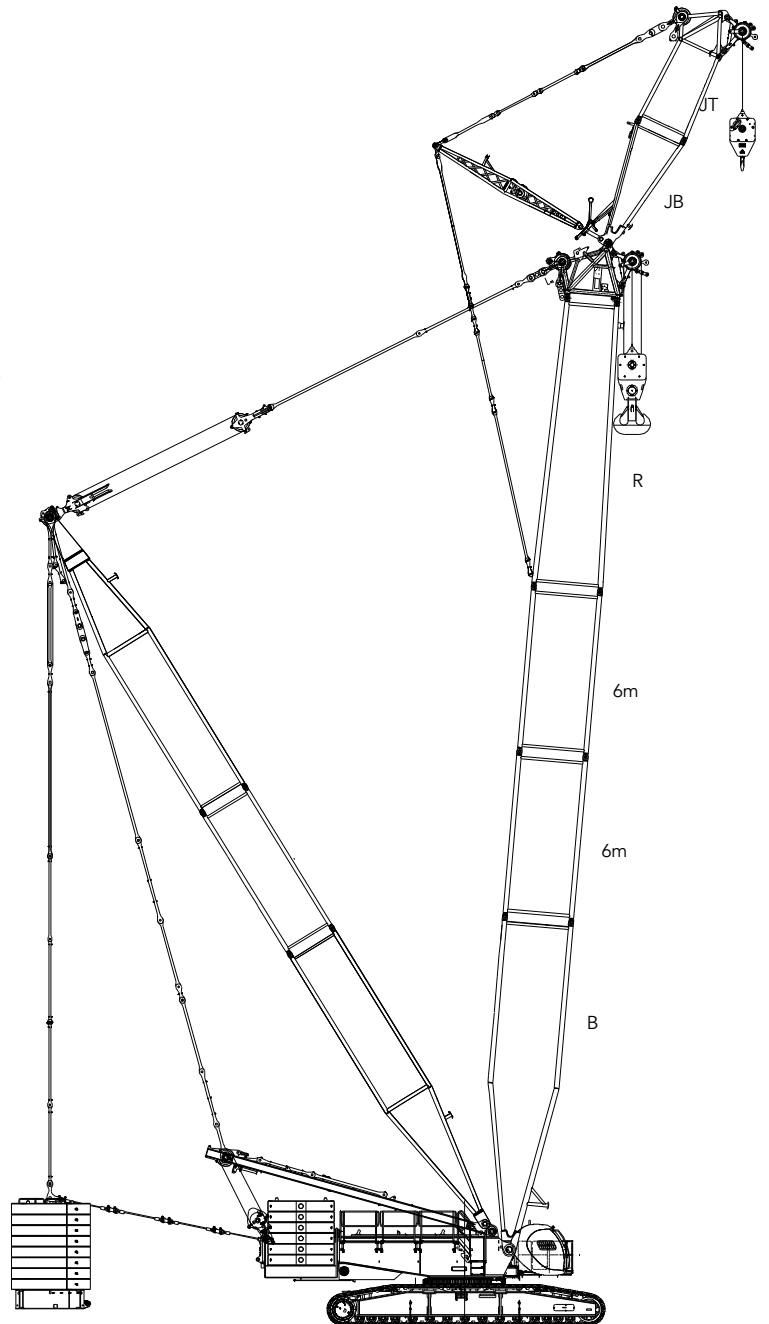

**FJhDB Configuration**  
118.12ft+29.5ft  
(36m+9m)

# Working Radius of FJhDB

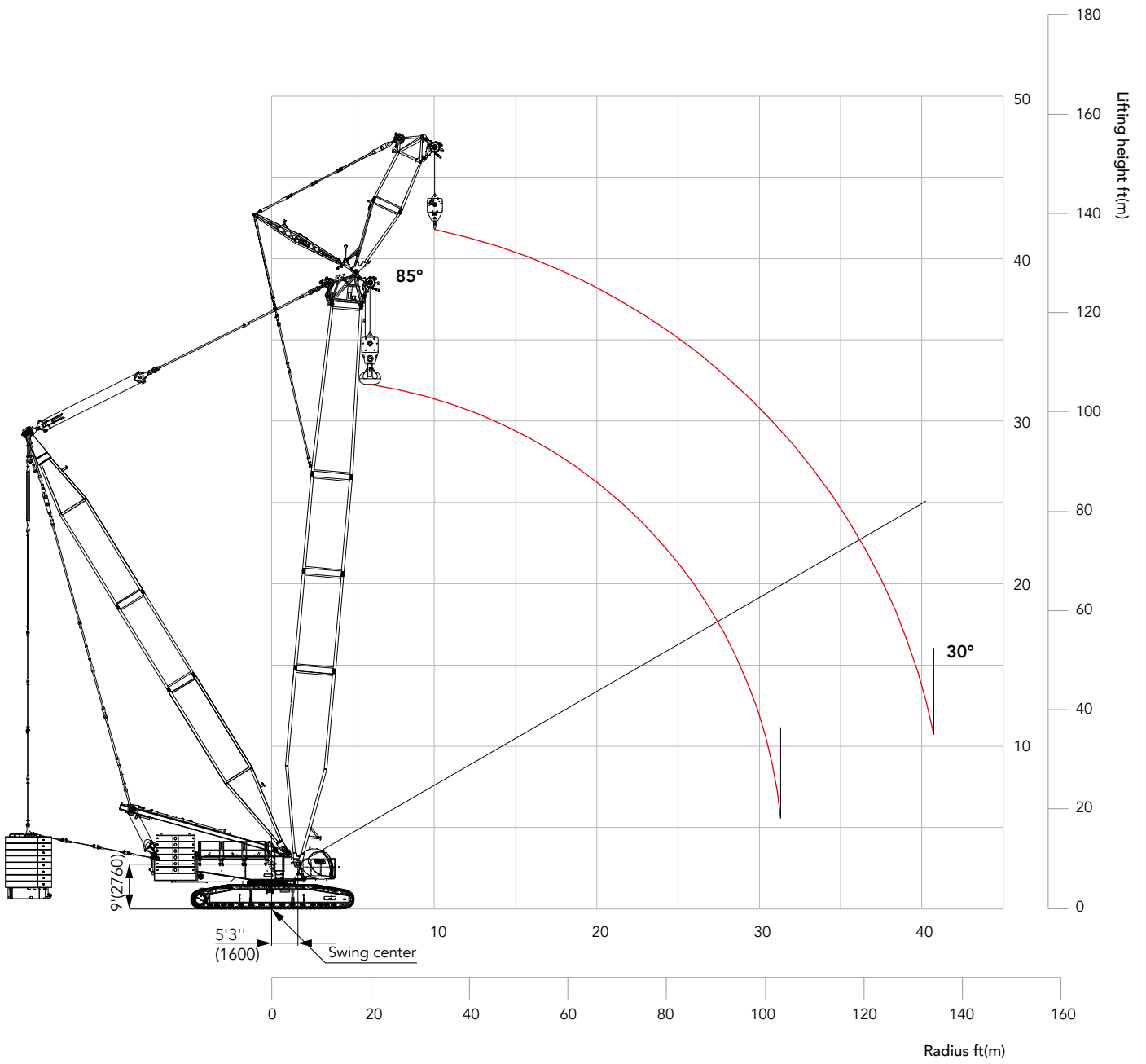

Unit:klb

## Load Chart of FJhDB

**Note:**

- 1.The rated load in the load chart is calculated complying with ASME B30.5;
- 2.The working radius is the horizontal distance from the load center to the swing center;
- 3.The actual lifting capacity must subtract the weight of hooks and other riggings from the rated capacity in the load chart;
- 4.The load value is calculated when the object is hung freely,without considering the influence of wind on the load, ground conditions and slope, operation speed and the influence of any other negative factors over safe operation. Therefore, the operator bears the responsibility of making a judgment and decreasing the load and lowering speed;
- 5.All ratings are calculated when the machine is parking on firm and level ground with less than 1% gradient;
- 6.See the Operation Manual for the complete load charts of FJhDB Configuration.

### FJhDB configuration load chart

Boom length 118.1~118.1ft, Jib length29.5ft, Boom to jib angle 20°, Superlift radius 49.2ft, Superlift counterweight 462,962lb, Rear counterweight 330,687lb, Carbody counterweight 88,183lb

Radius (ft)	Boom length(ft)		Radius (ft)
	118.1		
23.0	881.8*		23.0
25.0	881.8*		25.0
30.0	881.8*		30.0
35.0	881.8		35.0
40.0	877.4		40.0
45.0	842.1		45.0
50.0	764.4		50.0
55.0	686.3		55.0
60.0	620.3		60.0
65.0	566.6		65.0
70.0	521.6		70.0
75.0	481.7		75.0
80.0	446.5		80.0
85.0	416.2		85.0
90.0	389.2		90.0
95.0	365.4		95.0
100.0	344.1		100.0
104.9	324.0		104.9

Note:For values marked with "\*", the superlift counterweight shall not leave the ground.

**Load Chart of FJhDB****FJhDB configuration load chart**

Boom length 118.1~118.1ft, Jib length 29.5ft, Boom to jib angle 20°, Superlift radius 49.2ft, Superlift counterweight 462,962lb,  
Rear counterweight 330,687lb, Carbody counterweight 88,183lb

Radius (ft)	Boom length(ft)		Radius (ft)
	29.5		
36.1	372.5*		36.1
40.0	359.2*		40.0
45.0	340.7*		45.0
50.0	326.3*		50.0
55.0	312.9*		55.0
60.0	300.1*		60.0
65.0	290.0*		65.0
70.0	279.9*		70.0
75.0	269.8*		75.0
80.0	260.6*		80.0
85.0	253.9*		85.0
90.0	245.6*		90.0
95.0	239.3*		95.0
100.0	234.8*		100.0
105.0	231.4*		105.0
110.0	226.4*		110.0
115.0	221.8		115.0
120.0	217.7		120.0
130.0	211.4		130.0
131.2	210.7		131.2

Note:For values marked with "\*\*", the superlift counterweight shall not leave the ground.



## Boom Combination in LJ

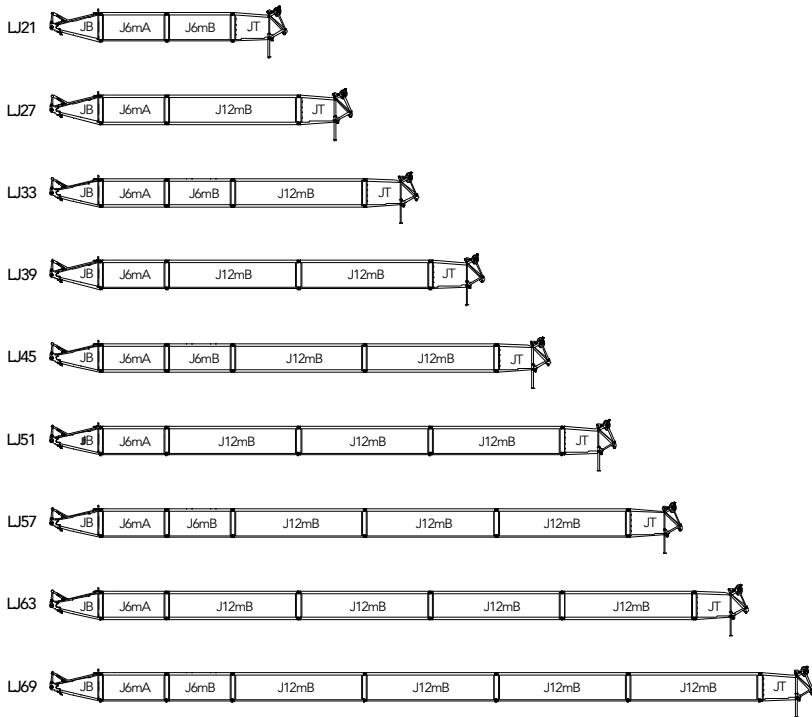

	Boom base
	Boom insert
	Boom insert
	Boom insert
	Tapered insert
	Boom tip
	Jib base
	Jib top
	Jib insert
	Jib insert
	Jib insert

Note: The 118.1ft~196.9ft(36m~60m) boom combination is the same as that of the H Configuration. For jib combination, the 14.8ft(4.5m) jib base, 19.7ft(6m) luffing jib insert A, and 14.8ft(4.5m) jib top are must.

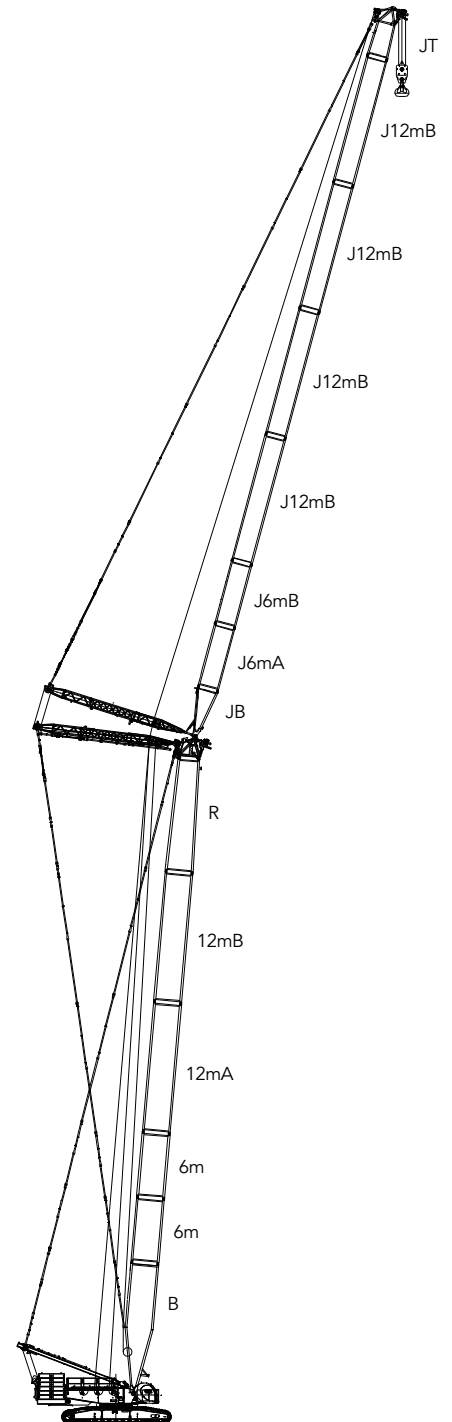

**LJ Configuration**  
(118.1ft~196.9ft)+(68.9ft~226.4ft)  
(36m~60m)+(21m~69m)



Unit:klb

## Load Chart of LJ

**Note:**

- 1.The rated load in the load chart is calculated complying with ASME B30.5;
- 2.The working radius is the horizontal distance from the load center to the swing center;
- 3.The actual lifting capacity must subtract the weight of hooks and other riggings from the rated capacity in the load chart;
- 4.The load value is calculated when the object is hung freely,without considering the influence of wind on the load, ground conditions and slope, operation speed and the influence of any other negative factors over safe operation. Therefore, the operator bears the responsibility of making a judgment and decreasing the load and lowering speed;
- 5.All ratings are calculated when the machine is parking on firm and level ground with less than 1% gradient;
- 6.See the Operation Manual for the complete load charts of LJ Configuration.

### LJ configuration load chart 1/2

Boom length 118.1-196.9ft,Jib length 68.9-226.4ft,Boom angle (85°,75°,65°),  
Rear Counterweight 330,687lb,Carbody Counterweight 88,183lb

Boom length 196.9ft

Radius (ft)	68.9			88.6			108.3			128			147.6			Radius (ft)
Angle	85°	75°	65°	85°	75°	65°	85°	75°	65°	85°	75°	65°	85°	75°	65°	Angle
50.0	243															50.0
55.0	227			220												55.0
60.0	209			203			196									60.0
65.0	194			188			182									65.0
70.0	181			176			170			165						70.0
75.0	169			164			159			154			149			75.0
80.0	159			154			149			145			140			80.0
85.0	150			145			141			136			132			85.0
90.0		113		137			133			129			125			90.0
95.0		109		130			126			122			118			95.0
100.0		103		124			119			116			112			100.0
105.0		97.6			94.5		114			110			106			105.0
110.0		92.9			90		108			105			101			110.0
115.0		88.4			85.7		103	82		100			96.7			115.0
120.0		84.2			81.7		98.7	78.2		95.6	75.3		92.3			120.0
130.0					74.6			71.3		87.7	68.6		84.5	65.3		130.0
140.0						53.3		68.7	50.9		81.1	63		77.9	59.8	140.0
150.0							50.3		48.5		60.3			57.9	72	150.0
160.0									44.4					53.4		160.0
170.0														49.4		170.0
180.0															33	180.0
190.0																190.0
200.0															30.3	200.0
210.0																210.0
220.0																220.0
230.0																230.0

**Load Chart of LJ****LJ configuration load chart 2/2**

Boom length 118.1-196.9ft,Jib length 68.9-226.4ft,Boom angle (85°,75°,65°),  
Rear Counterweight 330,687lb,Carbody Counterweight 88,183lb

Boom length 196.9ft

Radius (ft)	167.3			187			206.7			226.4			Radius (ft)
Angle	85°	75°	65°	85°	75°	65°	85°	75°	65°	85°	75°	65°	Angle
70.0													70.0
75.0	145												75.0
80.0	136			131									80.0
85.0	128			124									85.0
90.0	121			117			112						90.0
95.0	114			111			107			95.3			95.0
100.0	109			105			102			94.3			100.0
105.0	103			99.6			96.3			93			105.0
110.0	98.2			94.7			91.6			88.3			110.0
115.0	93.6			90.2			87.2			84			115.0
120.0	89.3			86			83.1			80.1			120.0
130.0	81.8			78.6			76			72.9			130.0
140.0	75.3			72.3			69.7			66.7			140.0
150.0	69.4	52.4		66.6	49.3		64			61.3			150.0
160.0	64.2	48.1		61.4	45.1		59	42.7		56.4	39.8		160.0
170.0	59.5	44.3		56.9	41.4		54.5	39		52	36.3		170.0
180.0	55.6	40.9		53	38.2		50.6	35.8		48.1	33.1		180.0
190.0		37.8		49.3	35.2		47	32.9		44.6	30.2		190.0
200.0		35	22.9		32.4		43.8	30.2		41.3	27.6		200.0
210.0			20.9		29.9	18.2	40.7	27.7		38.3	25.1		210.0
220.0			19		27.6	16.4	38	25.5		35.6	23.1		220.0
230.0			17.2		25.5	14.7		23.5	12.5	33.2	21		230.0
240.0			15.5			13		21.5	10.9		19.1	8.5	240.0
250.0						11.5			9.6		17.3	7.1	250.0
260.0						10.2			8.2		15.8	5.8	260.0
270.0									7		14.2	4.6	270.0
280.0									5.8			3.5	280.0
290.0												2.5	290.0
300.0												1.5	300.0
301.8												1.3	301.8



# Working Radius in LJDB

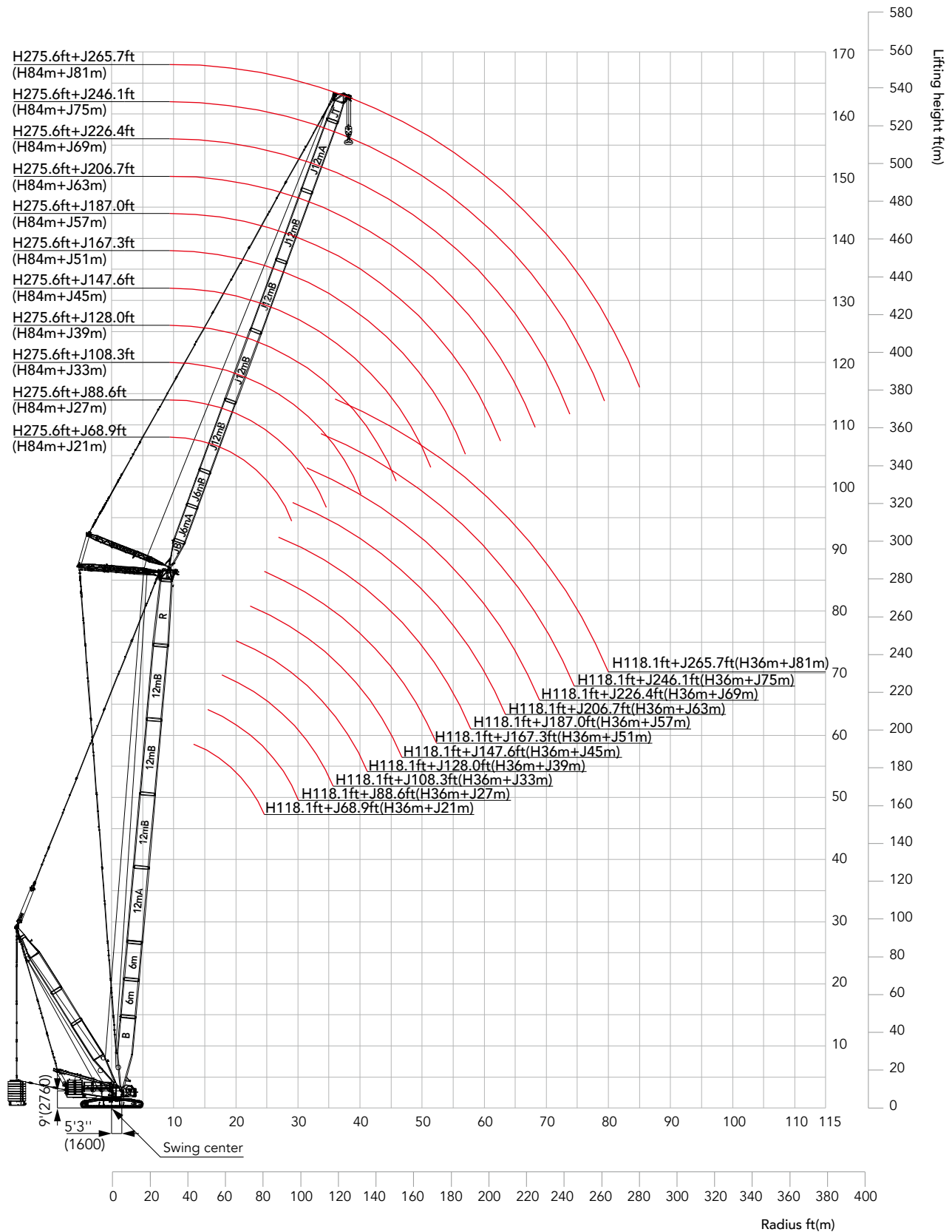

Unit:klb

## Load Chart of LJDB

**Note:**

- 1.The rated load in the load chart is calculated complying with ASME B30.5;
- 2.The working radius is the horizontal distance from the load center to the swing center;
- 3.The actual lifting capacity must subtract the weight of hooks and other riggings from the rated capacity in the load chart;
- 4.The load value is calculated when the object is hung freely,without considering the influence of wind on the load, ground conditions and slope, operation speed and the influence of any other negative factors over safe operation. Therefore, the operator bears the responsibility of making a judgment and decreasing the load and lowering speed;
- 5.All ratings are calculated when the machine is parking on firm and level ground with less than 1% gradient;
- 6.See the Operation Manual for the complete load charts of LJDB Configuration.

### LJDB configuration load chart 1/2

Load chart-LJDB(Boom length 118.1-275.6ft,Jib length 68.9-265.7ft,Superlift radius 49.2ft,Superlift counterweight 110,229lb, Rear counterweight 330,687lb,Carbody counterweight 88,183lb)

Boom 275.6ft

Radius (ft)	68.9			88.6			108.3			128.0			147.6			Radius (ft)
	85°	75°	65°	85°	75°	65°	85°	75°	65°	85°	75°	65°	85°	75°	65°	
52.5	227															52.5
55	224.5															55
60	219.5			195.2												60
65	214.6			191.3												65
70	208.9			187			165.6									70
75	203.1			182.7			162.6			143.9						75
80	197.5			178.3			159.4			141.8			124.8			80
85	192.1			173.7			156			139.4			123.3			85
90	183.5			169.3			152.5			136.9			121.6			90
95				165.1			149.1			134.3			119.7			95
100				161			145.7			131.6			117.8			100
105				157.4			142.4			128.9			115.9			105
110		129.8		154			139.2			126.4			113.9			110
115		125.3					136.1			123.8			111.8			115
120		119					132.2			121.1			109.6			120
130		108			106.4		121.8			114.3			105.6			130
140		98.4			97.2			94.9		105.6			99.4			140
150					93.4			91.4			89.1		92.3	86.1		150
160								90.1			87.5		85.2	84		160
170			67.9					83.3			81.2		78.8	77.9		170
180			63.1					77			75.7			72.5		180
190						56.8					70.3			67.5		190
200						52.7				50.6				63		200
210									46.9				44.9			210
220									43.7				41.9			220
230													39		36.5	230
240															33.9	240
250															31.5	250
260															29.2	260
270																270

## Load Chart of LJDB

LJDB configuration load chart 2/2																			
Load chart-LJDB(Boom length 118.1-275.6ft,Jib length 68.9-265.7ft,Superlift radius 49.2ft,Superlift counterweight 110,229lb, Rear counterweight 330,687lb,Carbody counterweight 88,183lb)																			
Boom 275.6ft																			
Radius (ft)	167.3			187.0			206.7			226.4			246.1			265.7			Radius (ft)
Angle	85°	75°	65°	85°	75°	65°	85°	75°	65°	85°	75°	65°	85°	75°	65°	85°	75°	65°	Angle
75																			75
80	109.3																		80
85	108.3																		85
90	107.1			93.2															90
95	105.8			92.4			80.3												95
100	104.5			91.4			79.8			68.4			59						100
105	103.1			90.6			79.1			68.1			58.8			50.7			105
110	101.6			89.4			78.3			67.4			58.3			50.3			110
115	100.1			88.3			77.4			66.8			57.9			50.1			115
120	98.5			87.2			76.6			66.3			57.5			49.9			120
130	95.3			84.7			74.9			64.9			56.5			49			130
140	92.2			82.3			73.1			63.6			55.4			48.2			140
150	87.3			80			71.1			62.1			54.3			47.3			150
160	81.1	81.1		76.9			69.1			60.6			53.2			46.5			160
170	74.8	74.8		71.7			67.1			59.1			51.8			45.6			170
180	70	69.6		66.5	66		63	62.9		57.6			50.7			44.6			180
190		64.8		62	61.4		59	58.3		55.4	54.9		49.5			43.5			190
200		60.4		58	57.2		55.2	54.1		52.4	50.8		47.7	48.2		42.4	41.8		200
210		56.4			53.3		51.5	50.4		48.9	47.1		44.7	44.5		41.4	40.9		210
220		52.9			49.8		48.2	47.1		45.9	43.8		40.2	41.3		40.4	37.9		220
230		49.6	33.8		46.6			43.9		43.1	40.7		36.3	38.4		38.7	35.1		230
240			31.5		43.7	28.2		41		40.5	38		32.9	35.8		36.5	32.5		240
250			29.1			26.1		38.4	23.2		35.5		29.7	33.3		34.2	30		250
260			27.1			24.2		36	21.3		33.2		26.7	31		32	27.8		260
270			25.2			22.4		33.8	19.8		30.9	16.5		28.9		30.1	25.8		270
280						17.2			15		25.6	12		23.9	10.1	29.1	21.1		280
290						8.8			7.1			4.6		16	3.3		13.9		290
300						7.7			5.9			3.5		14.4	2.2		12.4		300
310									4.7			2.3		12.8			10.8		310
320									4.1			1.7					9.4		320
328																	8.3		328







## Zhejiang Sany Equipment Co.,LTD

SANY Crawler Crane Industrial Park, No. 2188 Daishan Road, Wuxing District, Huzhou City, Zhejiang Province, P. R. China Zip 313028

Consulting [sanycrane@sanygroup.com](mailto:sanycrane@sanygroup.com) (Crane BU) / [crd@sany.com.cn](mailto:crd@sany.com.cn) (IHQ)

After-sales Service 0086-400 6098 318

**Reminder:**

Any change in the technical parameters and configuration due to product modification or upgrade may occur without prior notice. The machine in the picture may include additional equipment. This brochure is for reference only, and goods in kind shall prevail.

Copyright at SANY. No part of this brochure may be copied or used for any purpose without written approval from SANY.

© Edited in April 2022

